

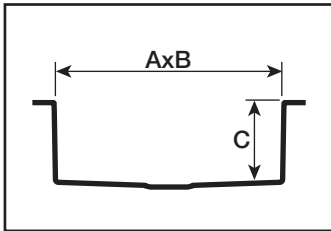

Roca

PARIS



PARIS				
	40	45	50	74
A	400	450	500	740
B	400			
C	200			

[mm]

40 A870J10400

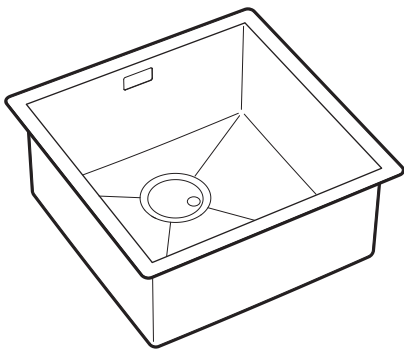

45 A870J10450

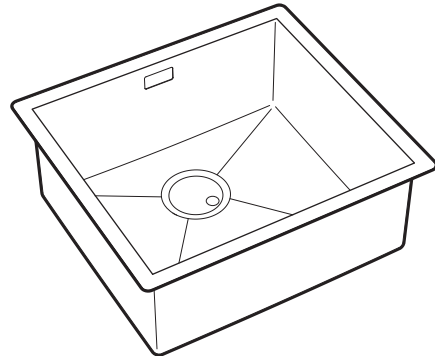

50 A870J10500

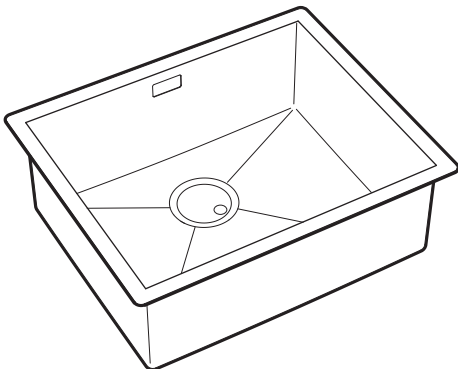

74 A870J10740

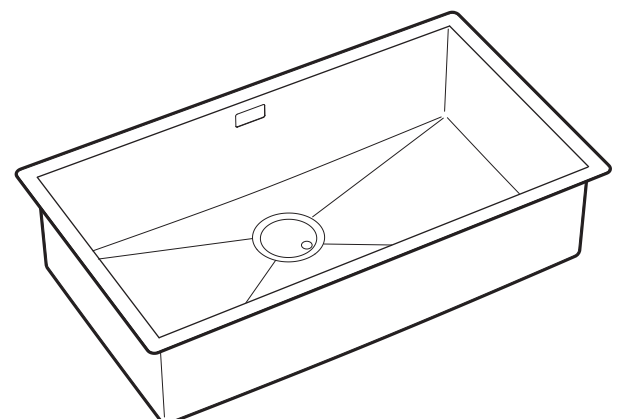

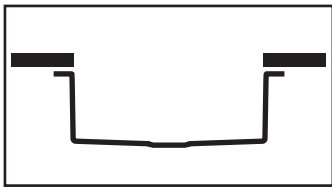

PARIS				
	40	45	50	74
X	398	448	498	738
Y	398	398	398	398

[mm]

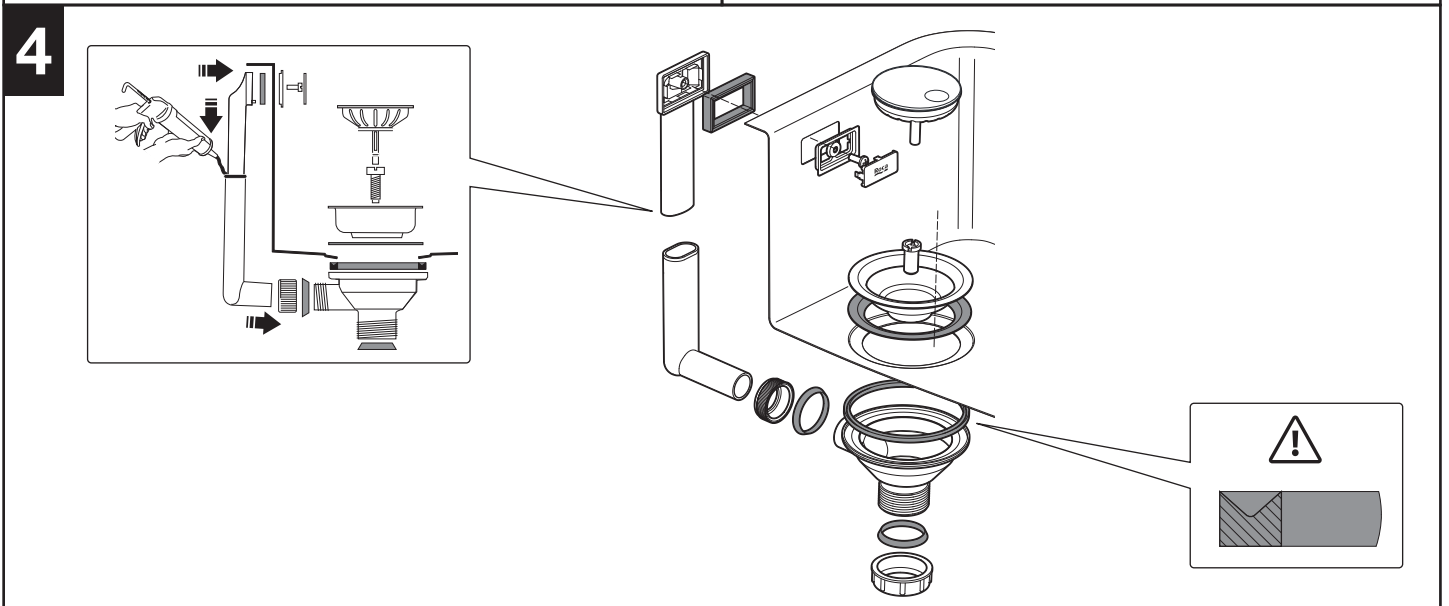
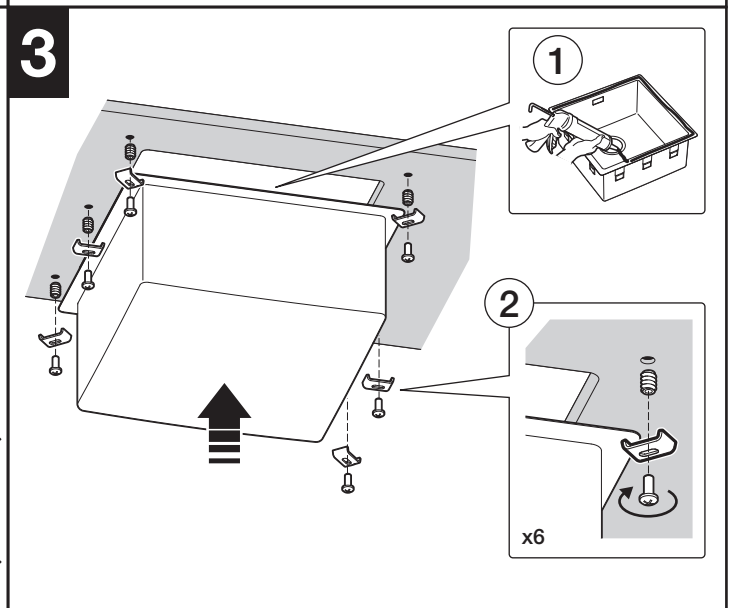
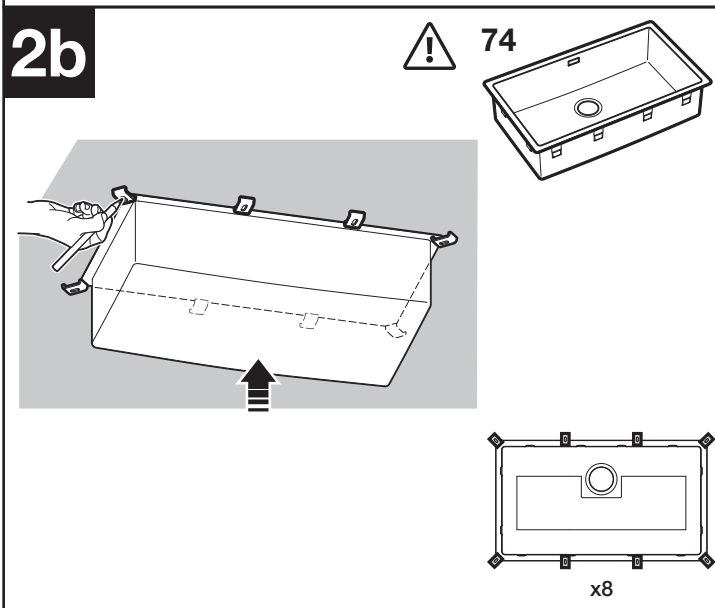
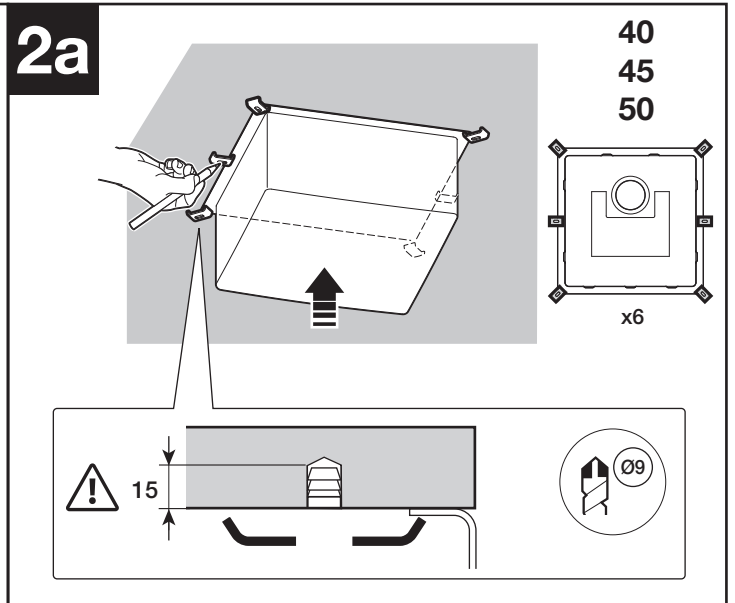
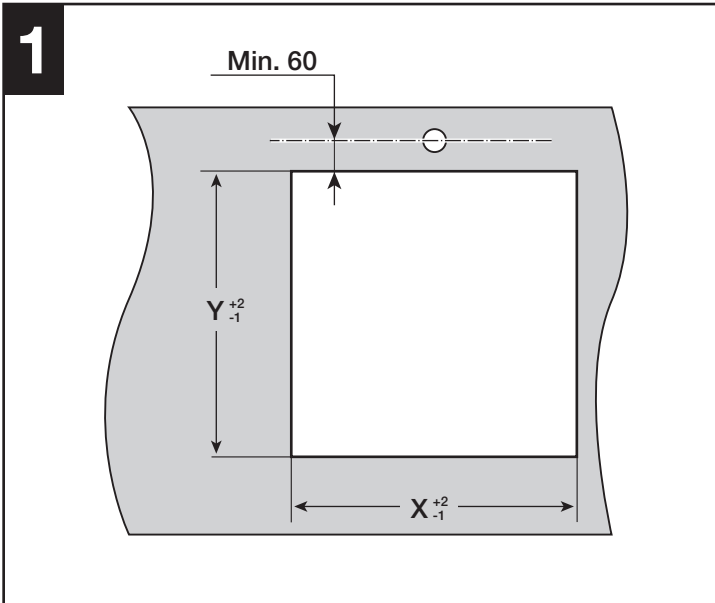

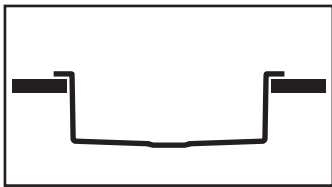

PARIS				
	40	45	50	74
X	416	466	516	756
Y	416	416	416	416

[mm]

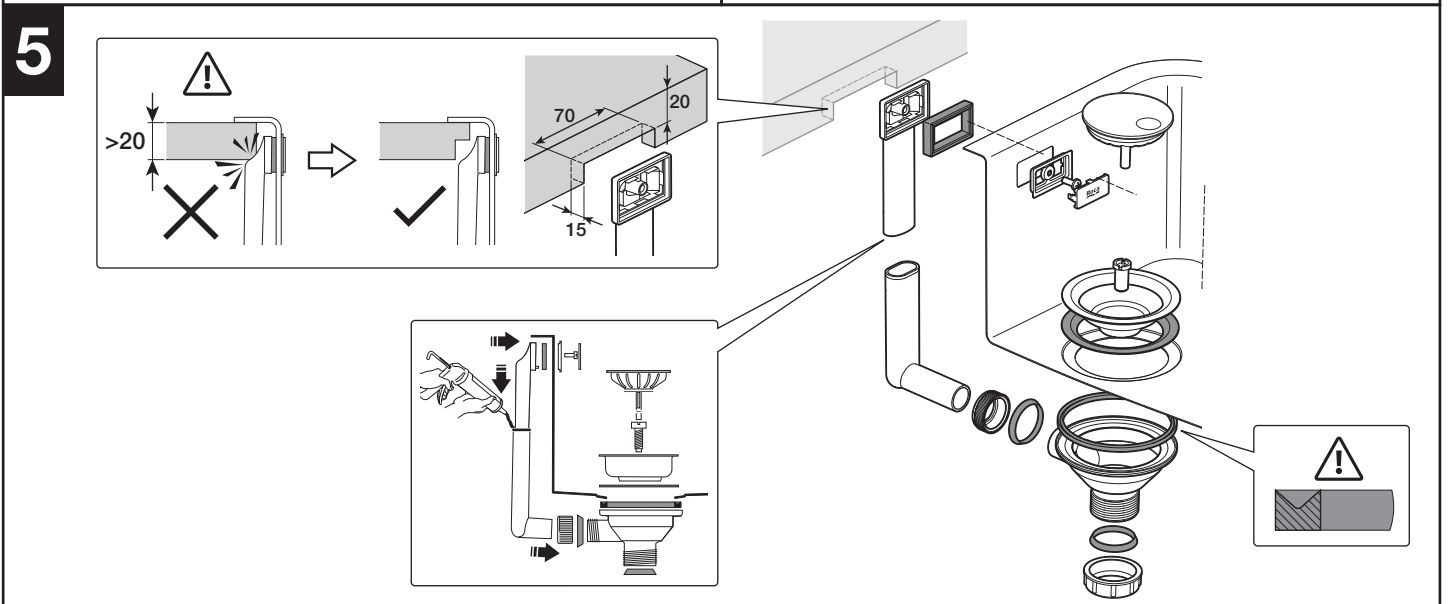
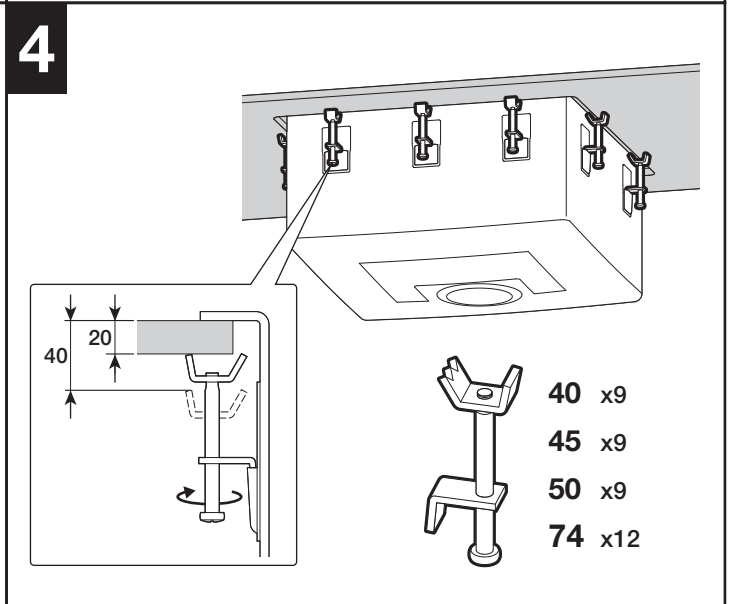
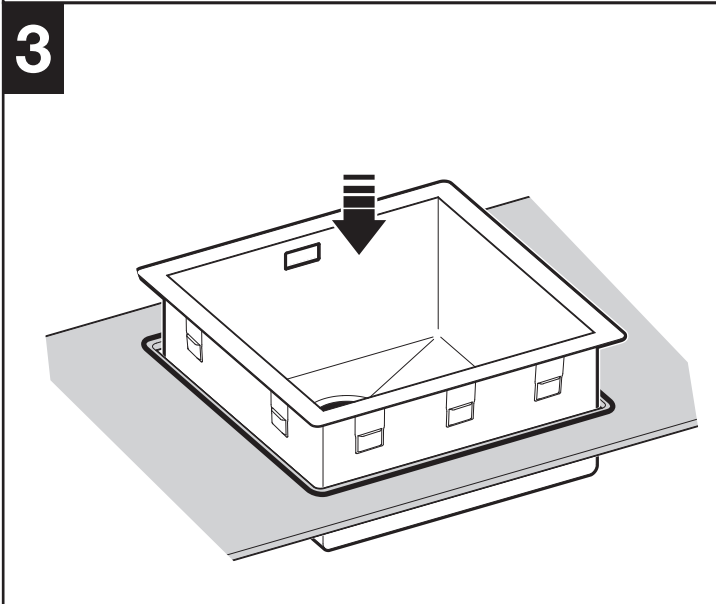
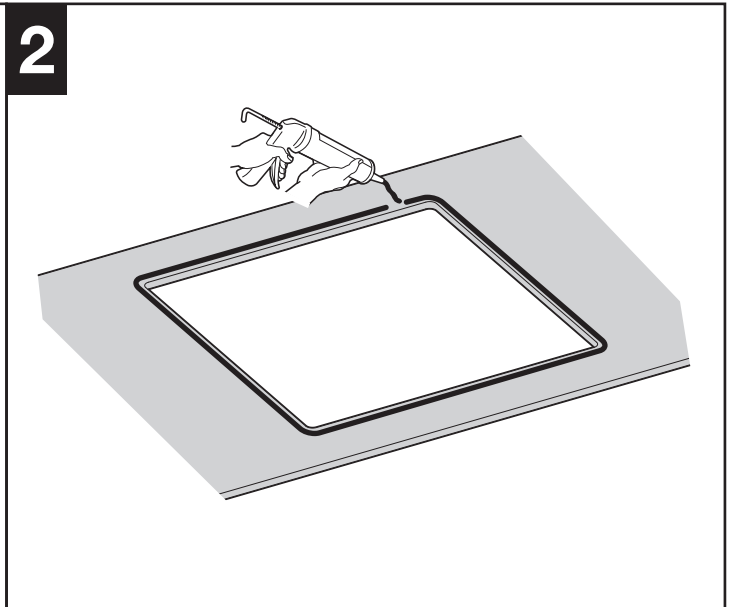
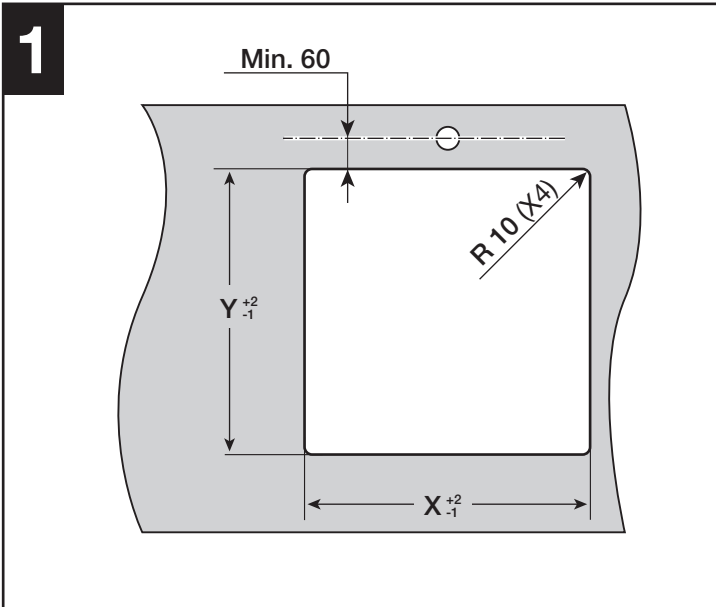



LIMPIEZA

- Limpie el fregadero con agua y detergente que no contenga cloro. Aclare bien y seque con un paño suave o gamuza.
- Si aparece una tonalidad mate en la superficie puede hacerla desaparecer puliendo con carbonato cálcico (o polvos de talco) o cualquier producto limpiametales no abrasivo.
- En el caso de manchas persistentes frote con un paño humedecido con amoníaco o vinagre caliente.

PRECAUCIONES

- No use para la limpieza de su fregadero materiales abrasivos (estropajos metálicos, etc.).
- No deje sobre el fregadero objetos metálicos oxidados o fácilmente oxidables.
- Evite almacenar productos corrosivos (sulfu-mán, aguafuerte, etc.) en recipientes abiertos debajo del fregadero.

CLEANING

- Clean the sink with water and chlorine-free detergent. Rinse well and dry with a soft cloth or chamois.
- If a matte shade appears on the surface, it can be cleared with calcium carbonate (talc powder) or any other non-abrasive metal polish product.
- In case of persistent stains, rub with a cloth damped with ammonia or hot vinegar.

PRECAUTIONS

- Do not use abrasive materials for cleaning the sink (steel wool, etc.).
- Do not leave easily corrosive objects on top of the sink.
- Do not store corrosive products (hydrochloric acid, etching, etc.) in open containers under the sink.



Roca Sanitario, S.A.
Avda. Diagonal, 513
08029 Barcelona
SPAIN
www.roca.com

**902
304
848** 
LÍNEA DE
ATENCIÓN AL
CONSUMIDOR
ESPAÑA

**902
400
423** 
SERVICIO
TÉCNICO
ESPAÑA



productsupport.rs@roca.net
soporteproducto.rs@roca.net