



RST260-2 MONTAGEANLEITUNG

Telefon: +49 721 530 772 0
Fax: +49 721 530 772 22
E-Mail: phos@phos.de

PHOS
Edelstahl Design

PHOS Design GmbH
Werftstraße 12
76189 Karlsruhe
www.phos.de

1 Bohrungen

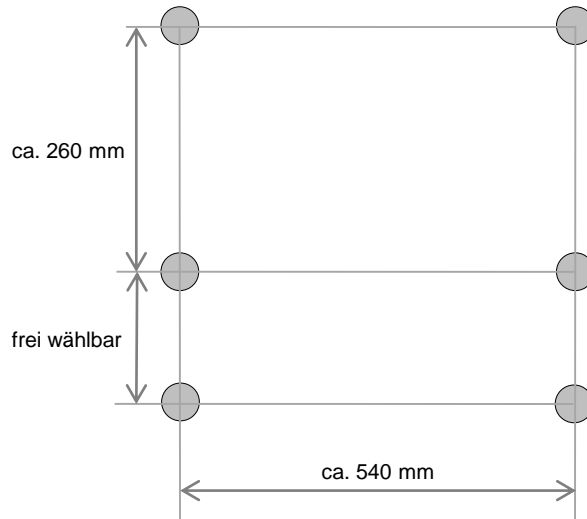

2 Dübel

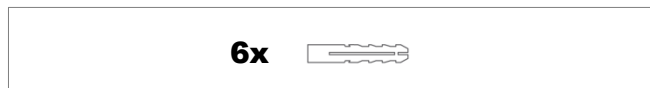
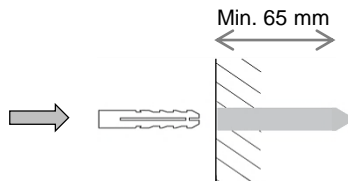

3 Montage der Stockschrauben

jeweils 6x

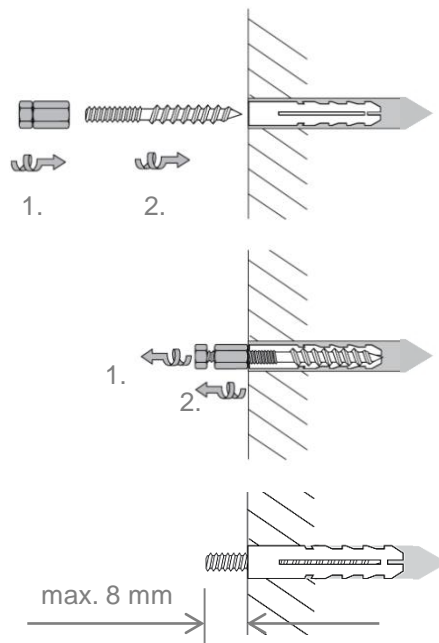

4 Montage der Adapterstücke & Glasträger

Jeweils 2x

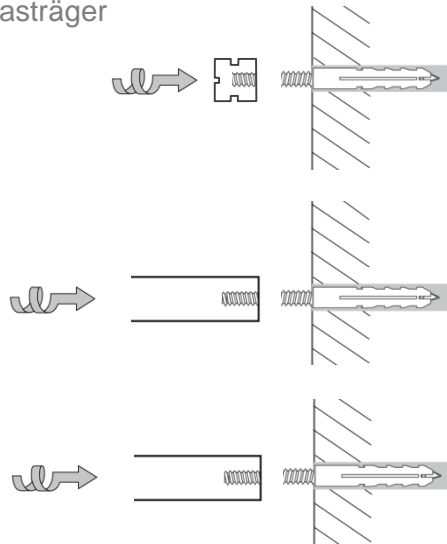

5 Montage des Seilträgers

5a

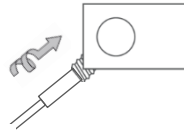

5b

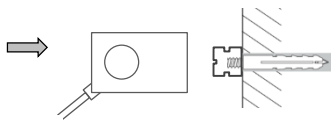

5c

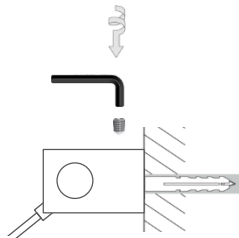

6 Auffädeln der Glasträger

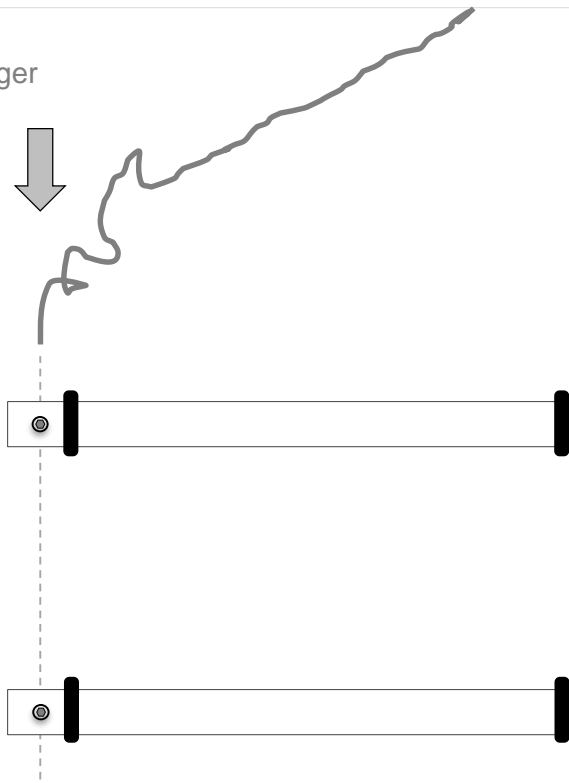

7 Fixieren der Seile

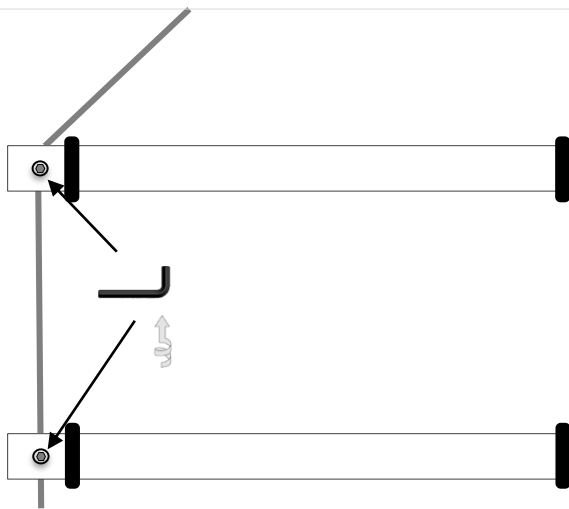

8 Überstand abschneiden

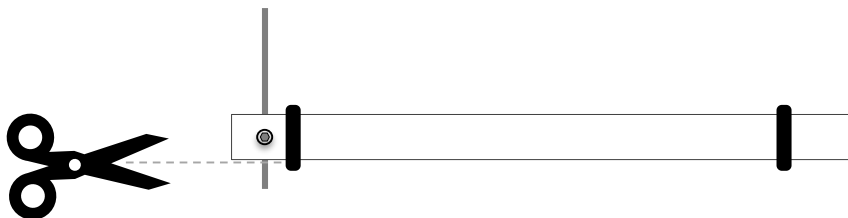

**Legen Sie anschließend vorsichtig die Glasböden ein.
Danach ist die Montage abgeschlossen.**