



Dornbracht

Leg Shower<sup>ATT</sup>

Planning guide

02 Introduction

05 Planning

15 Installation

25 Product details

33 Addresses

## INTRODUCTION

Planning  
Installation  
Product details  
Addresses

## FUNCTIONS

Components

# Functions



Add-on module



Leg shower

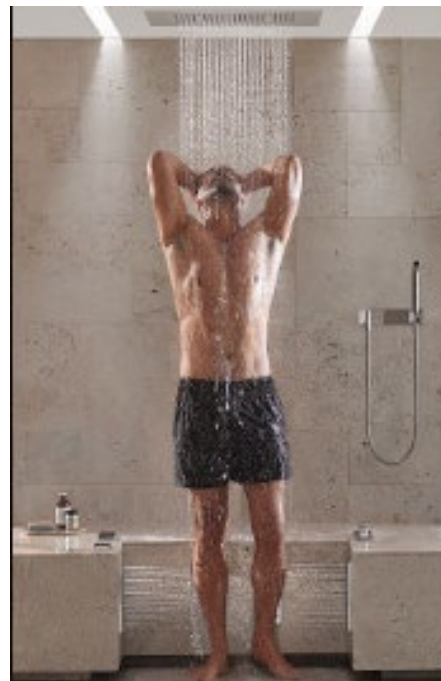

Scenarios

LEG SHOWER<sup>ATT</sup> is designed as an add-on module. A shower controlled by SMART TOOLS, such as the COMFORT SHOWER<sup>ATT</sup>, can be enhanced with the LEG SHOWER<sup>ATT</sup>. Scenarios use different functions in a pre-programmed sequence.

It is obligatory for technical planning, installation and initial commissioning to be accompanied by a certified system partner or by booking a Dornbracht service package.

Detailed information on the service package can be found at [www.dornbracht-professional.com](http://www.dornbracht-professional.com).

# Exposed trim components

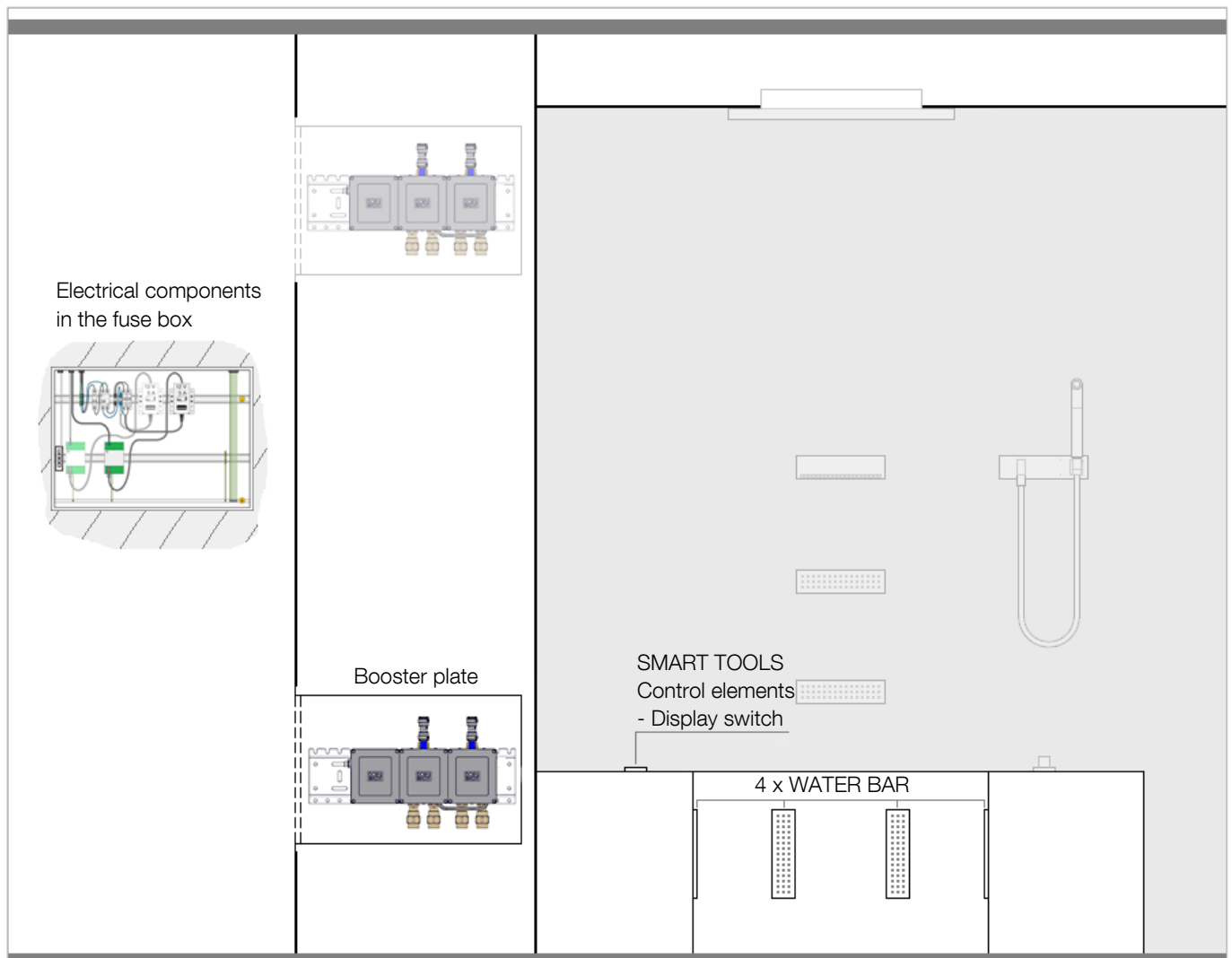

Electrical components supplied  
(in the fuse box)

- DC-Filter 1 x 5 A
- 1 x power supply unit 100 – 240 V AC / 12 V DC, 5 A

## Concealed rough components

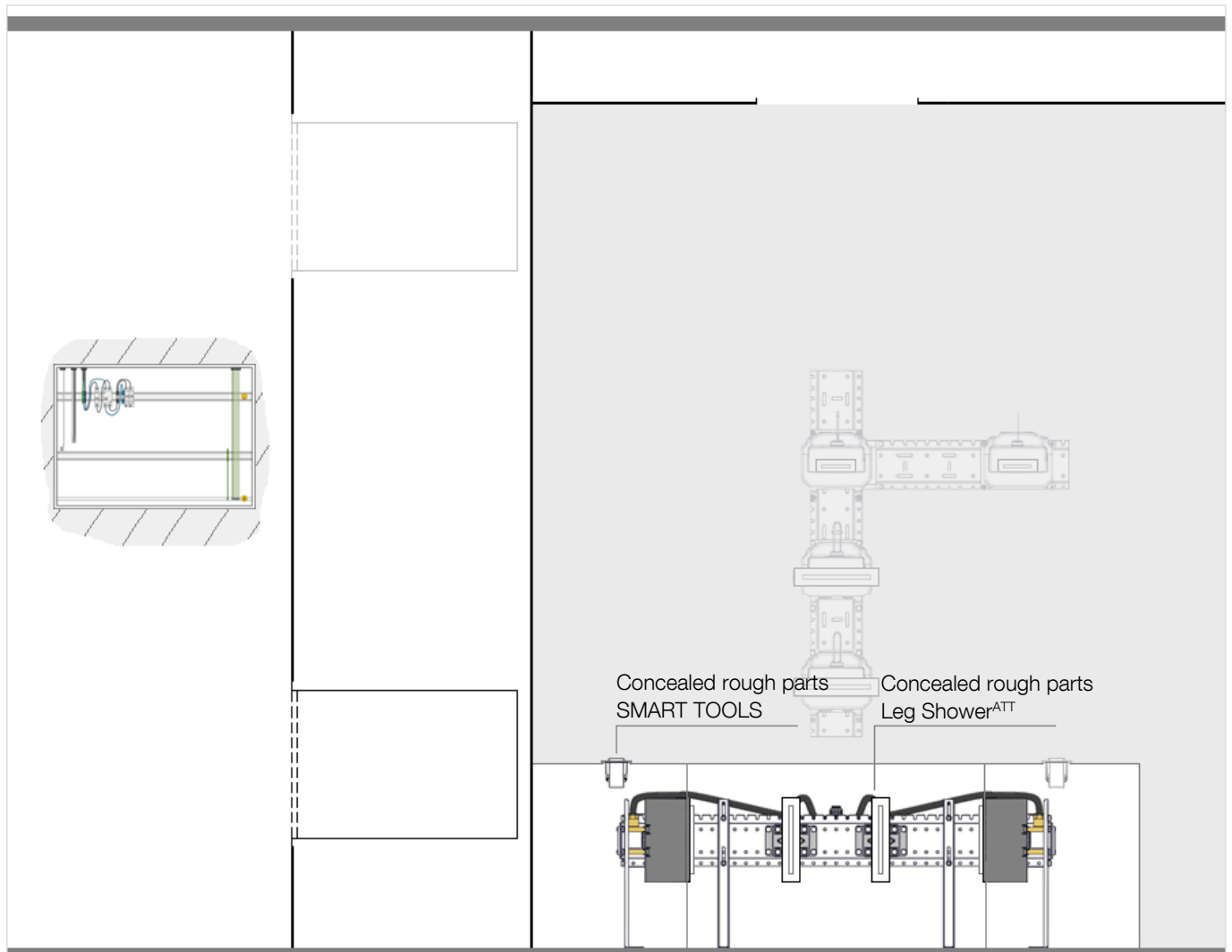

Additional components supplied but not shown:

Electrical components

- 1 x cable (12 V DC, 5 A)
- 1 x equipotential bonding cable (4 mm<sup>2</sup> / AWG 11)
- 2 x VBUS cable

Plumbing components

- 2 x stop valve (DN 20)
- 2 x strainer (DN 20)
- 2 x Y press and flush device
- 2 x feed pipes (DN 13)

## Safety zones

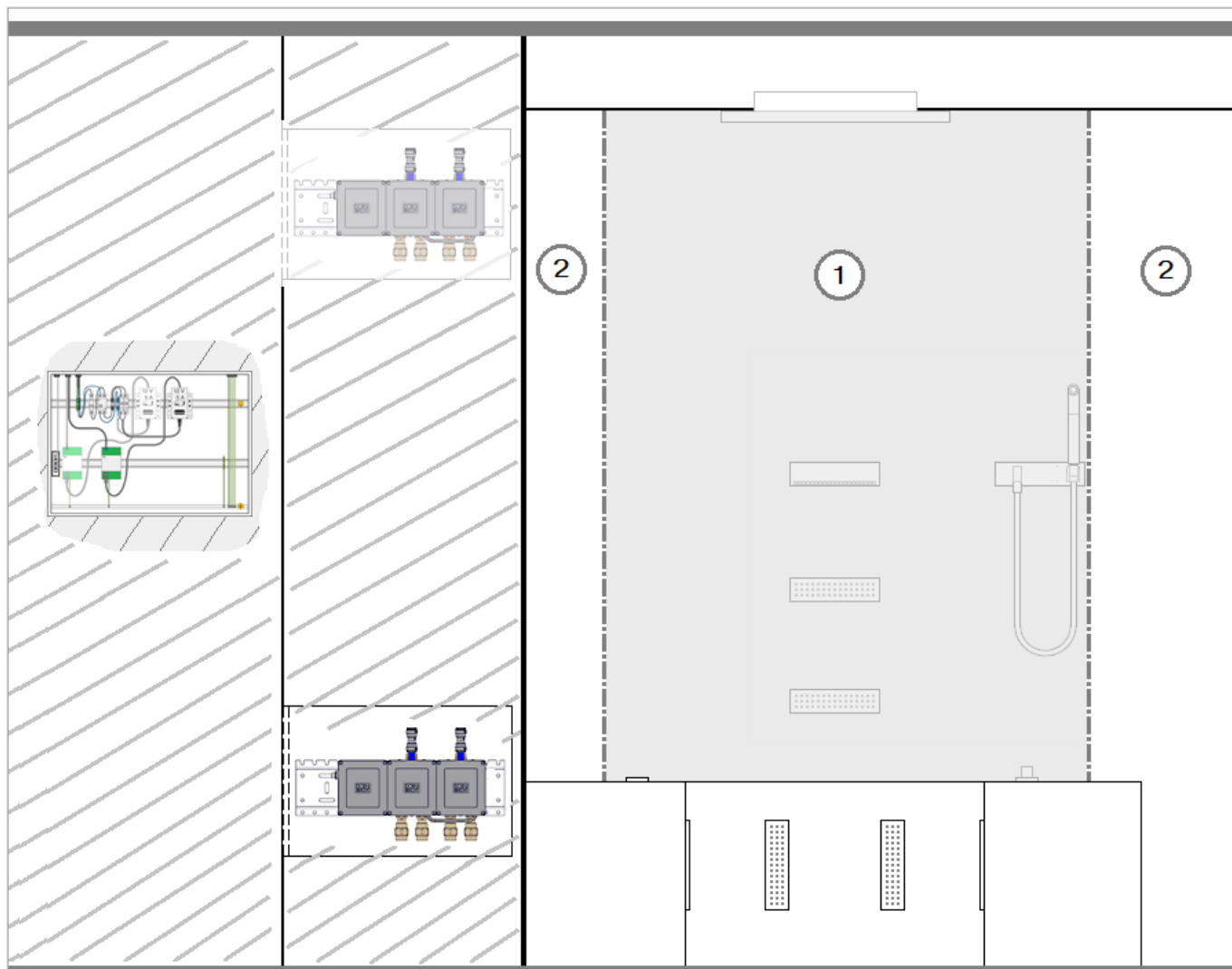

Comply with the regulations for safety zones in accordance with DIN VDE 0100, part 701.

Please conform to national statutory regulations, where different.

Observe the protection rating of each electrical component, only applicable once the device is fully installed.

The following electrical components must be installed outside safety zones 0 - 2:

fuse box, booster plate

As SMART TOOLS control elements are operated by safety extra-low voltage (12 V), they can be installed in safety zone 1.

# Positioning

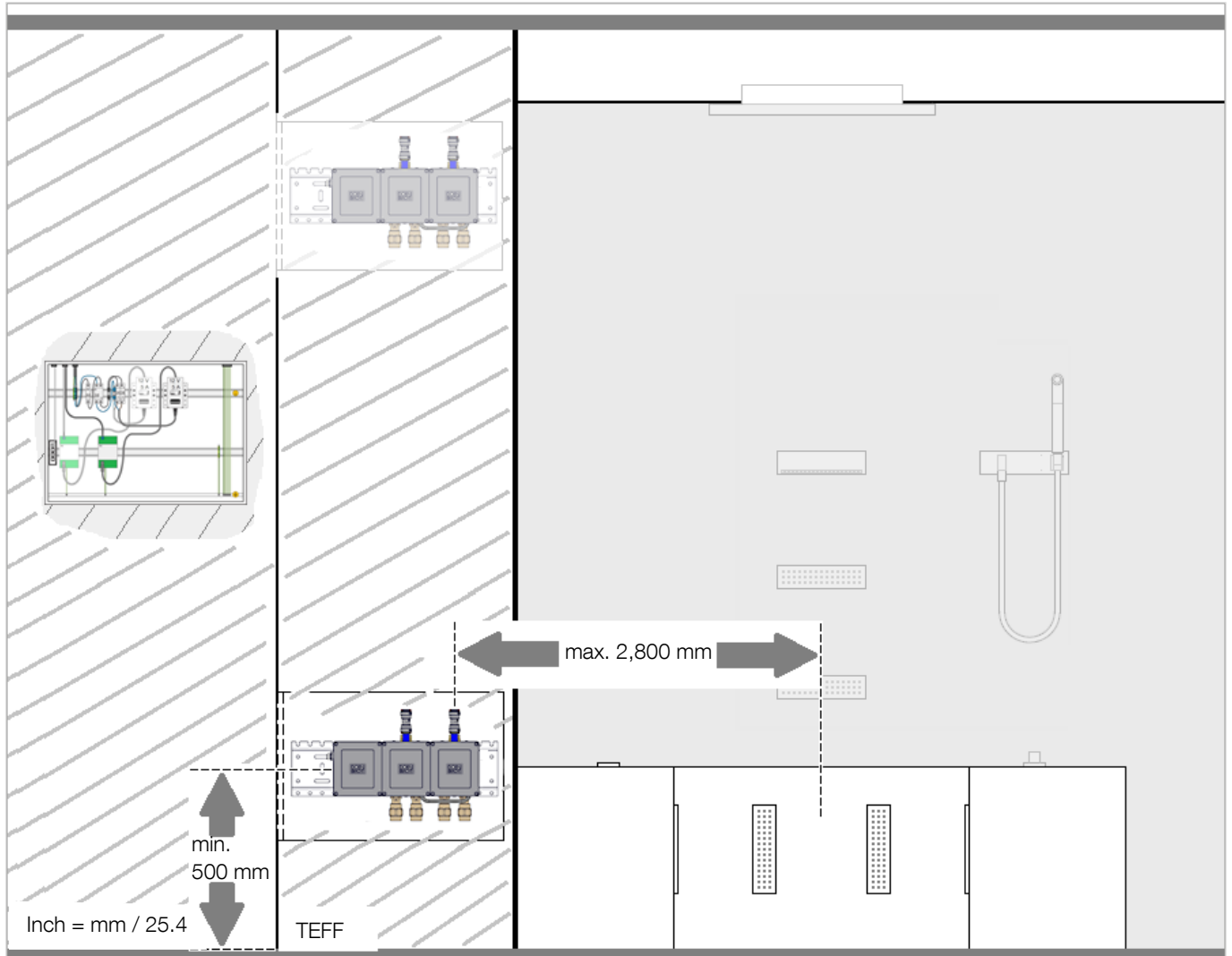

The booster plate and power supply installations must be physically separate.

The booster plate must not be installed above the power supply.

Fuse box with electrical components

- 12,000 mm / 39 ft 4-3/8" maximum distance to the booster plate
- outside the wet zone
- accessible for inspection
- 5 – 35 °C / 41 – 95 °F ambient temperature

Booster plate

- 2,800 mm / 9 ft 2-1/4" maximum distance to the centre of the concealed rough parts for the LEG SHOWER<sup>ATT</sup>
- 500 mm / 1 ft 7-3/4" minimum height difference between the top edge of the finished floor (TEFF) and the booster plate (centre of the xGRID track)
- accessible for inspection
- 5 – 55 °C / 41 – 131 °F ambient temperature

# Pre-wall system

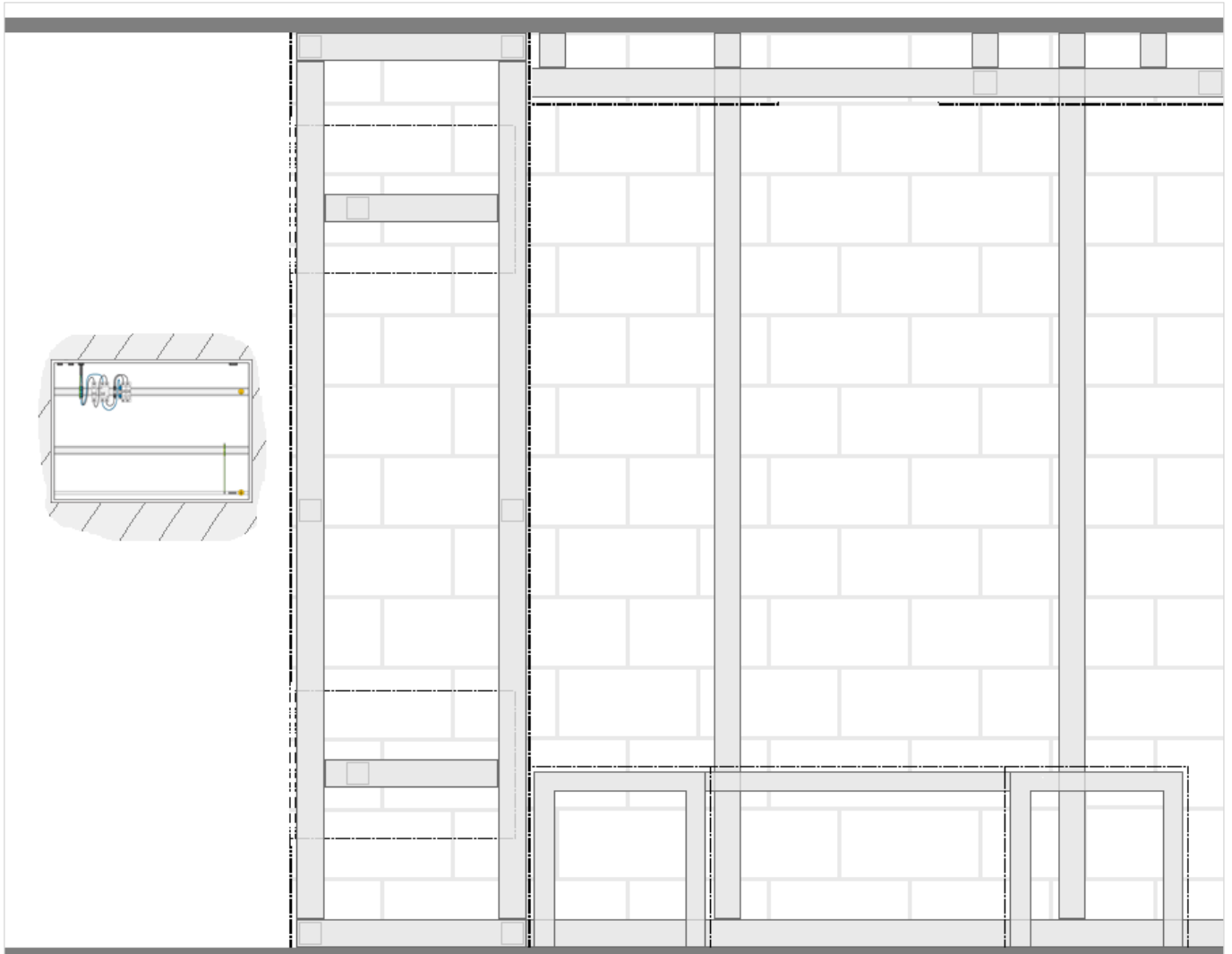

The recess depths required for the booster plate, the LEG SHOWER<sup>ATT</sup> concealed rough parts and the control elements make it essential to have a pre-wall system at the wall and bench.

The booster plate can be perfectly positioned in a lightweight wall.

Provide a bench construction with adequate structural strength. The top of the bench needs to slope slightly so that the water can drain.

The proper execution of the pre-wall installation, can ensure compliance with soundproofing, heat insulation and fire protection standards.

Pre-wall installation systems are available from various suppliers (e. g. Geberit, Tece, Viega, etc.).

Pre-wall installations can also be implemented with C-profiles (e. g. Knauf, Rigips Saint-Gobain, Sheetrock, Siniat, etc.).

Wood can also be used, unless this contravenes the regulations of the country concerned.

# Operating conditions

## Application

The product is not designed for outdoor use.

Dornbracht must be consulted before operating the device in a steam, chlorine or salt-laden atmosphere.

Water quality must be ensured by installing a filter or a water conditioning system.

Major differences between the hot and cold water supply must be balanced.

Maximum permissible relative humidity (without condensation) 95 %

## Permissible ambient temperatures

Booster plate 5 – 55 °C / 41 – 131 °F

SMART TOOLS control elements 5 – 35 °C / 41 – 95 °F

Storage 5 – 35 °C / 41 – 95 °F

Store somewhere dust-free and dry.

## Permissible operating temperatures

Cold water temperature 5 – 20 °C / 41 – 68 °F

Hot water temperature 55 – 65 °C / 131 – 149 °F

Recommended hot water temperature 60 °C / 140 °F

Thermal disinfection (max. 15:00 mins.) 75 °C / 167 °F

## Flow pressure

Permissible flow pressure 250 – 400 kPa / 36 – 58 psi / 2,5 – 4 bar

Recommended flow pressure 300 kPa / 44 psi / 3 bar

Fit a speed-controlled pressure booster in the main pipe, if necessary.

## Water hardness

Recommended water hardness: 6 – 7 °dH / 107 – 125 ppm / 7.5 – 8.8 °e / 10.7 – 12.5 °fH

Fit a water softener into the main pipe, if necessary. The reduction in pressure caused by the water softener must be taken into account.



# Basic dimensions

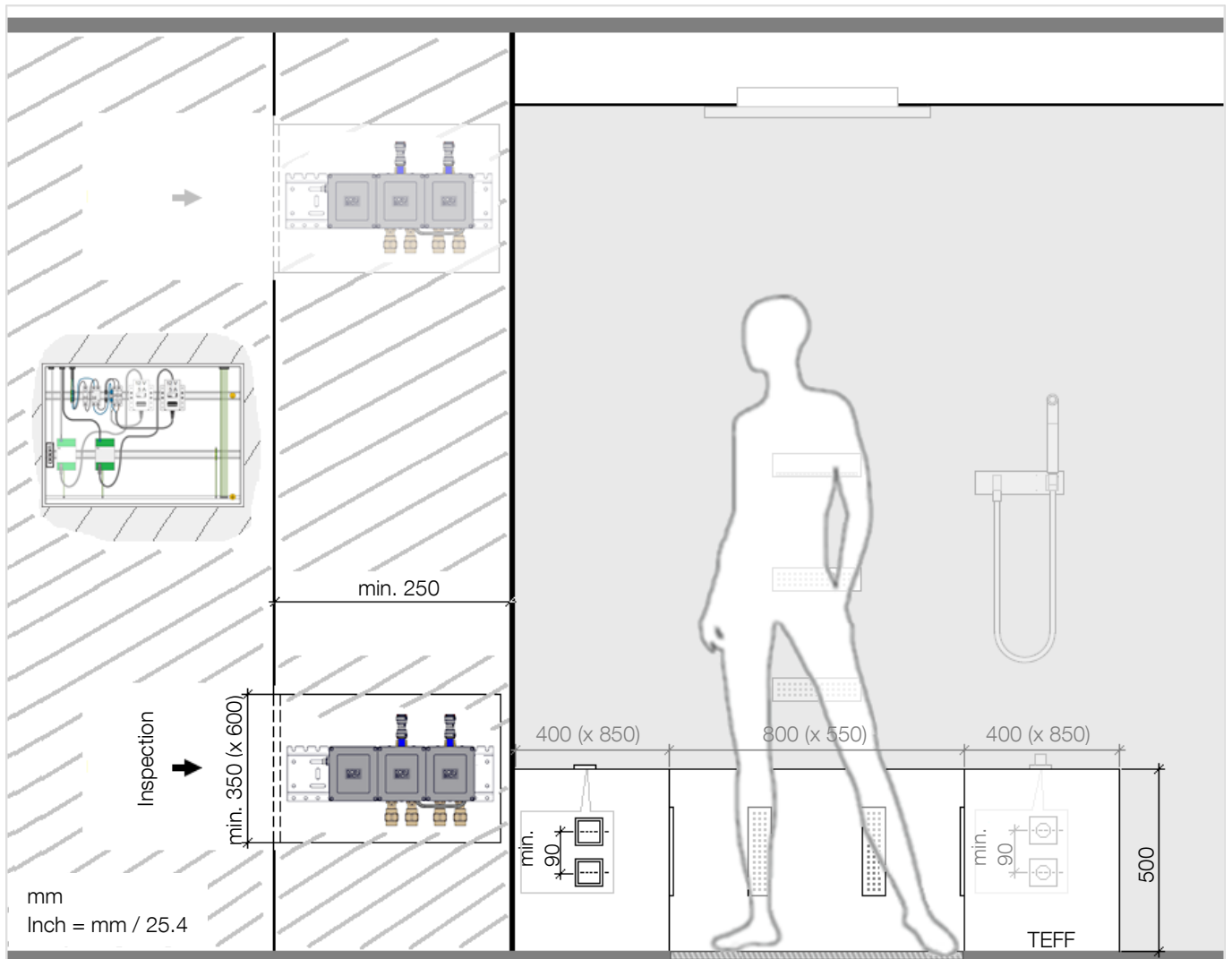

- 350 x 600 mm / 1 ft 1-5/8" x 1 ft 11-5/8" minimum size of the inspection opening
- 250 mm / 10" minimum thickness of the lightweight wall
- 90 mm / 3-1/2" minimum horizontal and/or vertical distance (centre / centre) for SMART TOOLS
  - The distance must never be less than this!-
- 500 mm / 1 ft 7-3/4" minimum seat height

- 800 x 550 mm / 2 ft 7-1/2" x 1 ft 9-5/8" recommended seat size
- 400 x 850 mm / 1 ft 3-5/8" x 2 ft 9-5/8" recommended size of the sides

## Standard construction

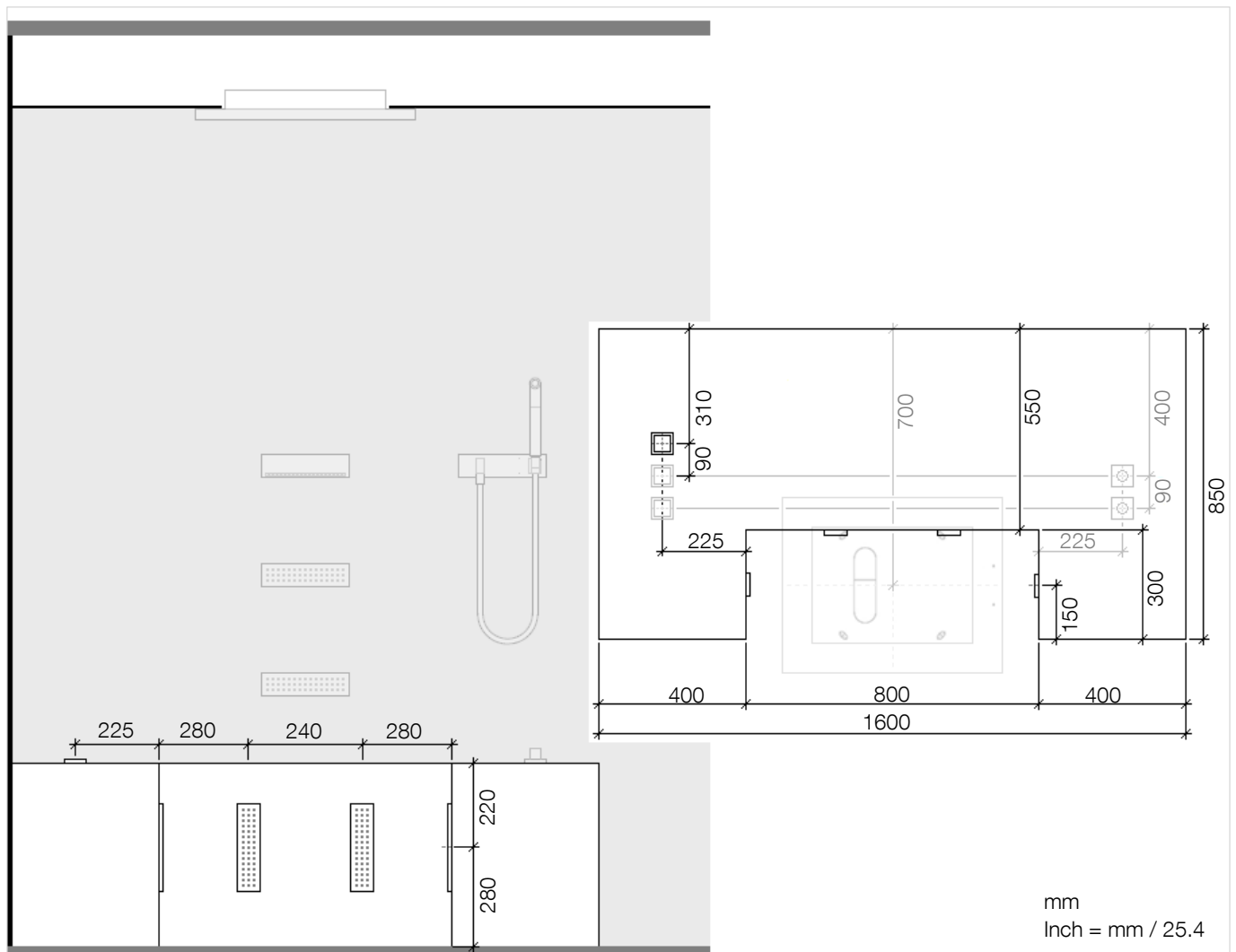

The positions and dimensions can be adapted to meet individual needs.

See installation examples.

## Cutouts / attachment points

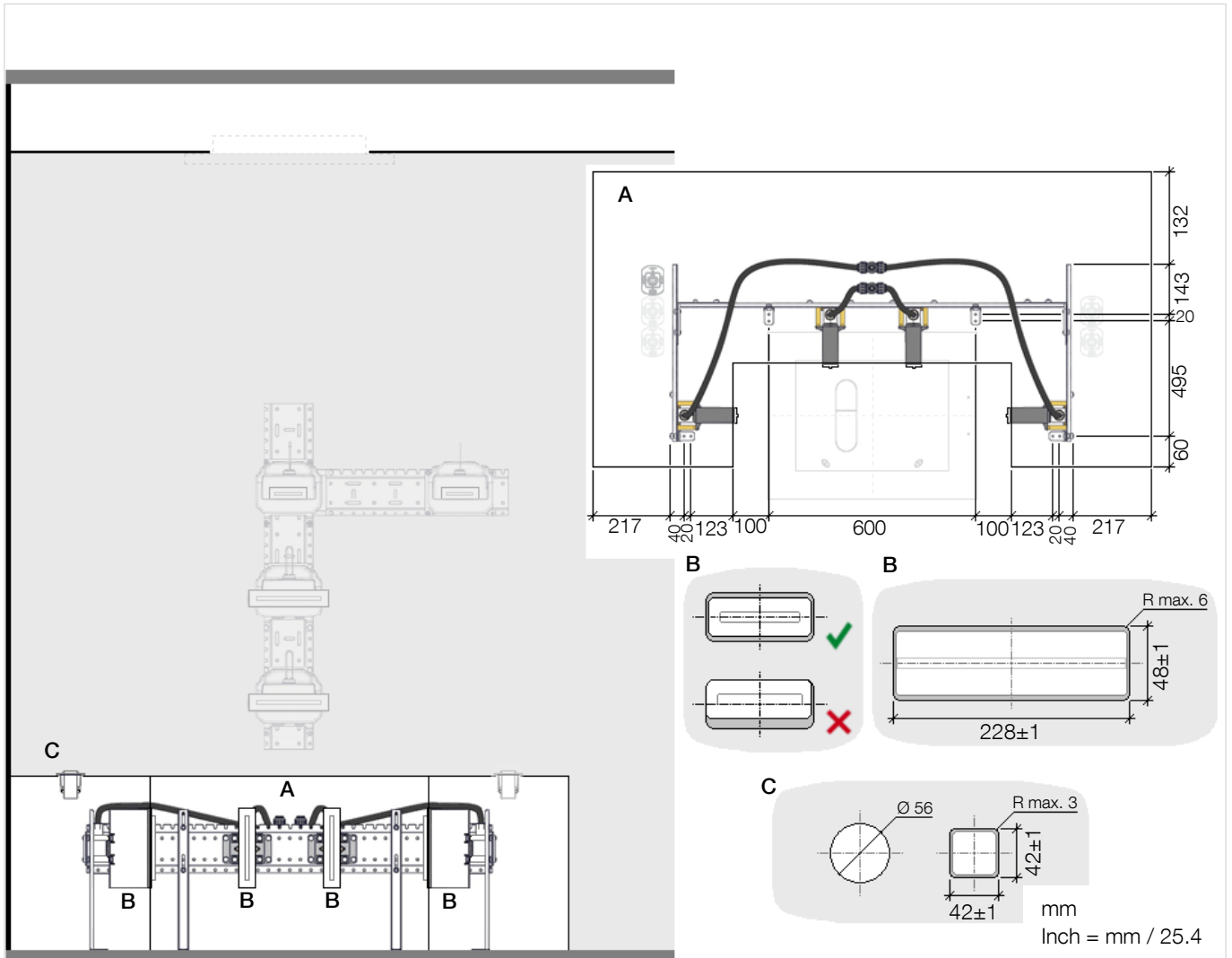

**A** – Concealed rough parts for the LEG SHOWER<sup>ATT</sup>

**B** – WATER BARS

**C** – SMART TOOLS control elements

**I** The concealed rough parts for the LEG SHOWER<sup>ATT</sup> and SMART TOOLS, as well as the VBUS cable must be fitted and tested before the pre-wall is closed.

For the control elements:

- Ø 56 mm drilled hole in the panelling for the concealed rough parts
- 42±1 x 42±1 mm cutout in the construction (tiles, natural stone, etc.)

# Pre-wall system

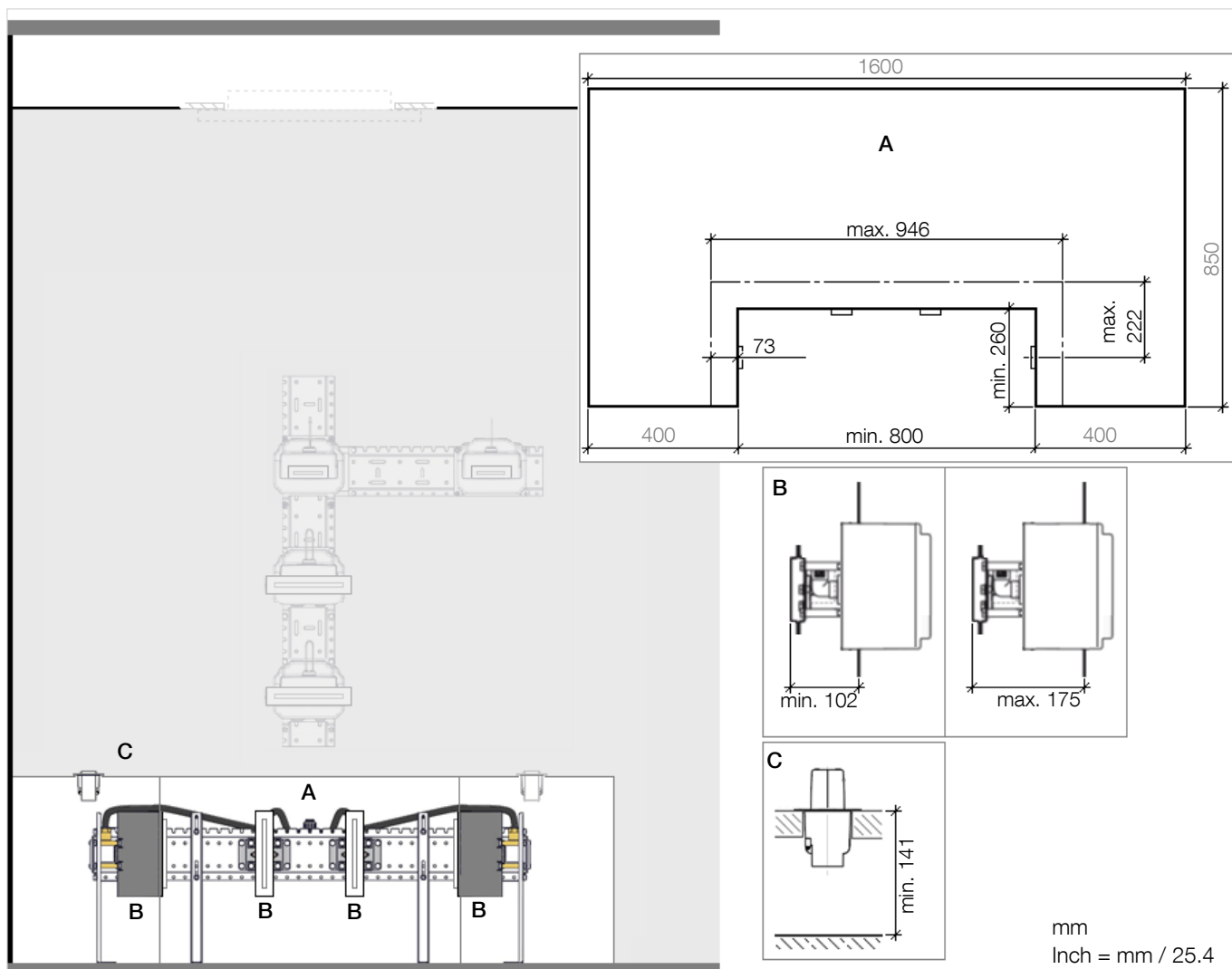

Note the recess depths of the components.

The LEG SHOWER<sup>ATT</sup> concealed rough parts are fitted below the bench surface.

The SMART TOOLS concealed rough parts are fitted in the surface panelling of the bench.

## Dry wall construction

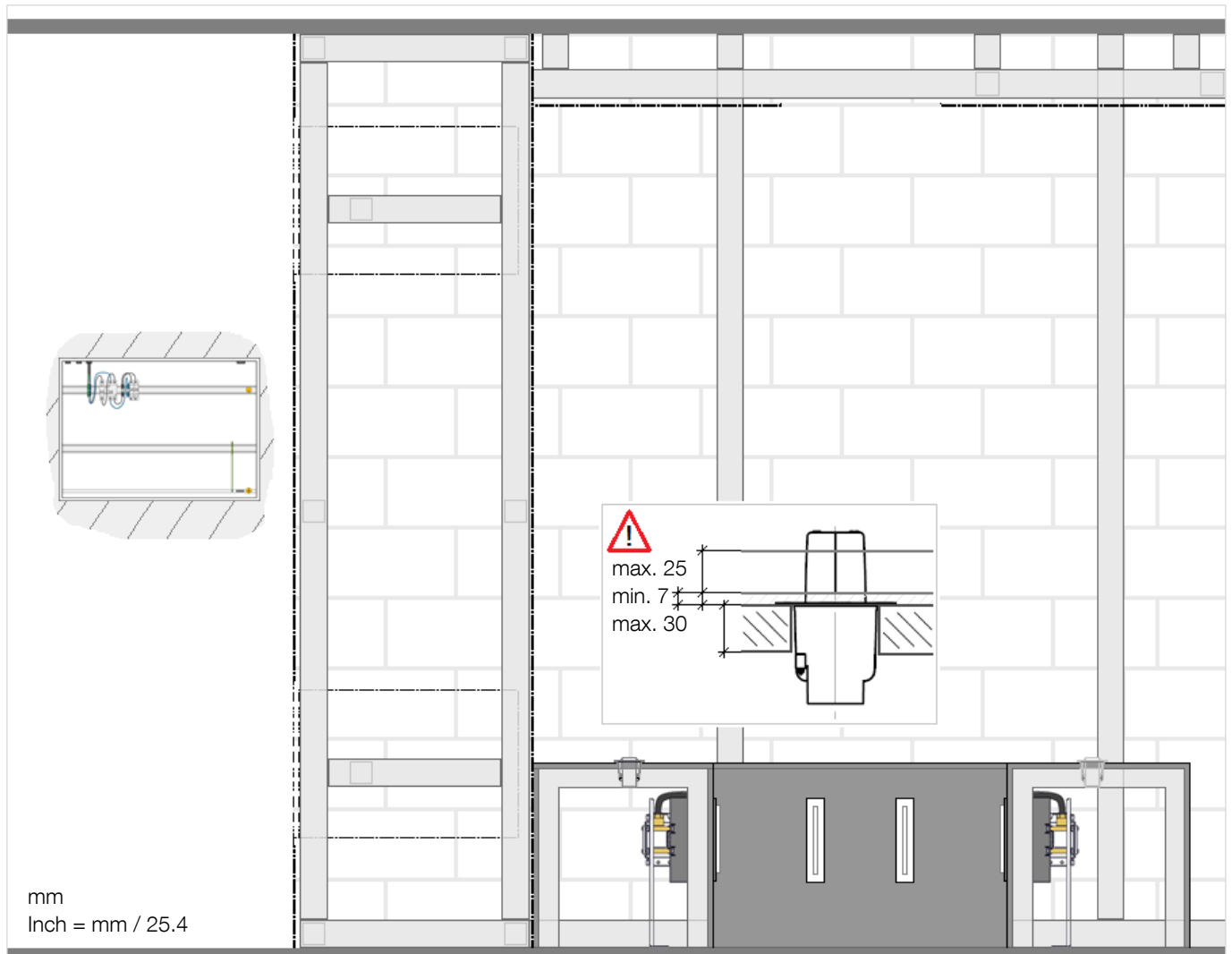

- 30 mm possible maximum thickness of the panelling for the control elements.
- 7 – 25 mm construction (tiles, natural stone, etc.), possible in front of the (plasterboard, etc.), panelling for the control elements.

- The concealed rough parts of SMART TOOLS and the VBUS cable must be fitted before the bench is closed. Relevant openings must be taken into account.

# Leg Shower<sup>ATT</sup>

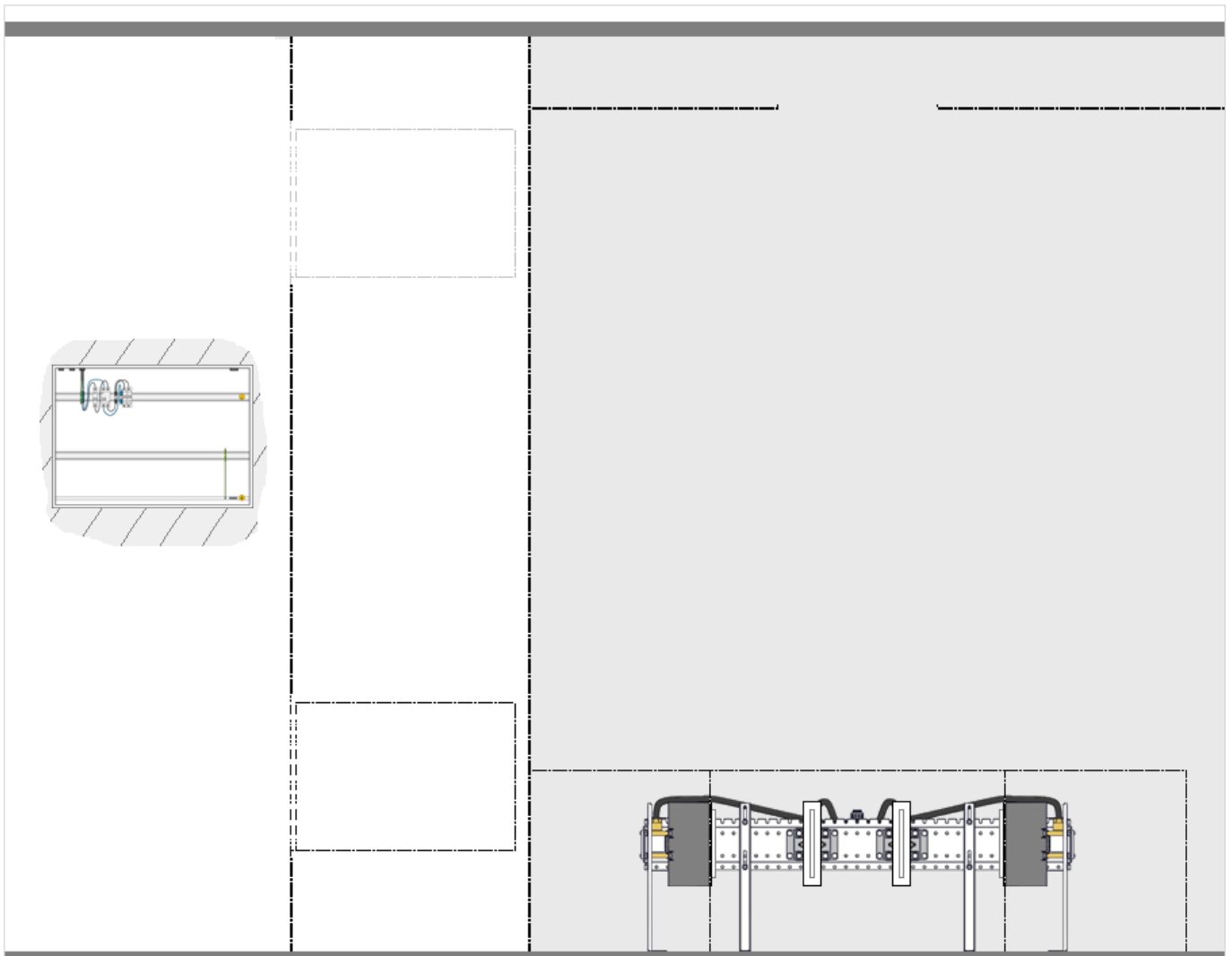

A floor with adequate structural strength for the LEG SHOWER<sup>ATT</sup> (weight: 12 kg / 26.5 lbs (US)) is essential. It is essential for the LEG SHOWER<sup>ATT</sup> to be permanently fixed to the floor.

The weight of the bench construction must not be carried by the LEG SHOWER<sup>ATT</sup>.

- ⚠ It takes 2 people to fit the concealed rough parts!
- ⚠ Wear safety gloves.

The fixing materials included among the items supplied are only suitable for mounting in concrete.

The customer must provide suitable fixing materials for the particular floor.

# Fuse box

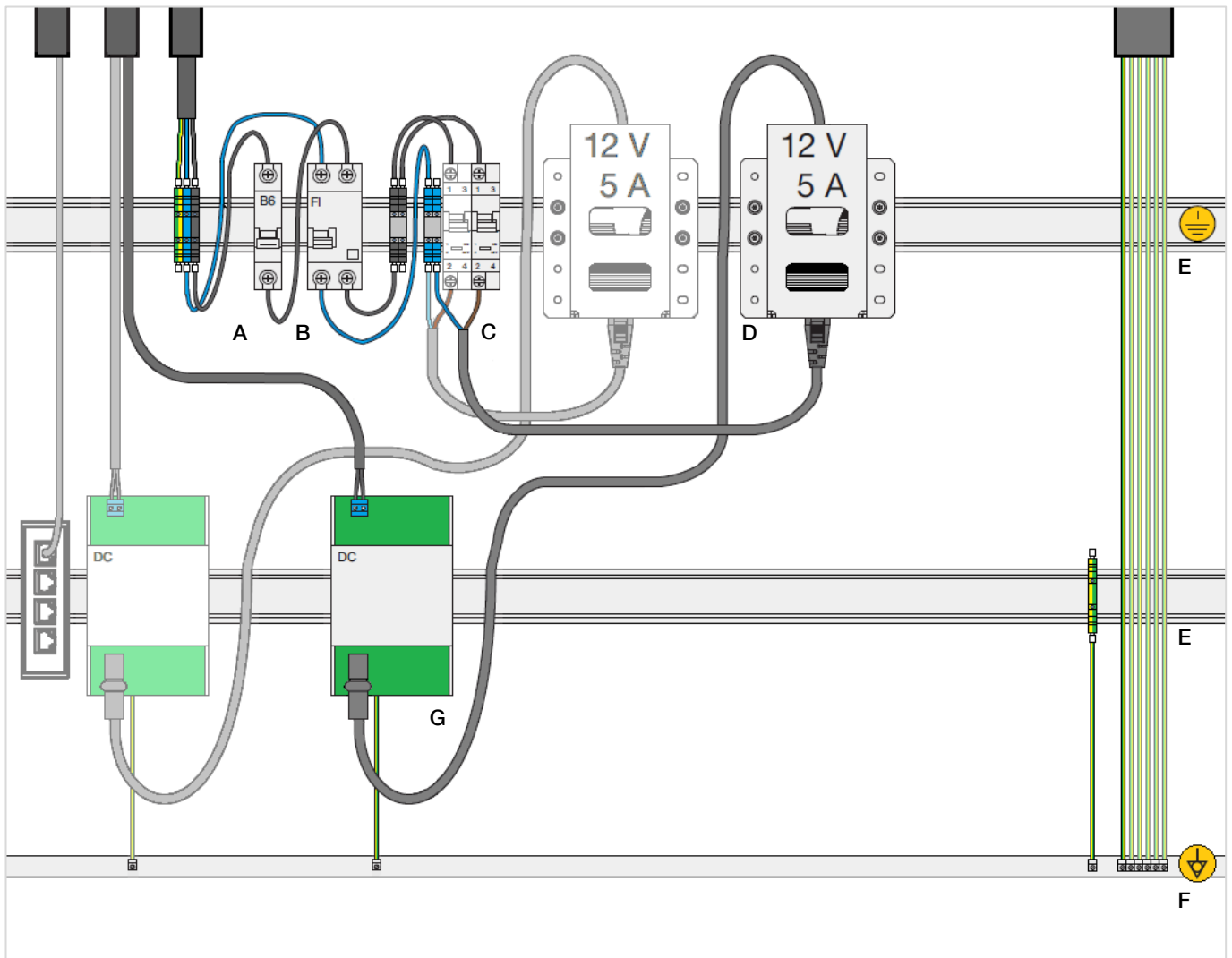

Space required for electrical components in the fuse box:  
 min. 500 x 500 x 150 mm / 1 ft 7-3/4" x 1 ft 7-3/4" x 6"  
 (inside).

Electrical components (scope of supply)

**D** – Power supply unit 100 – 240 V AC / 12 V DC, 5 A

**G** – DC filter 1 x 5 A

The customer must provide the following circuit breakers and electrical components:

**A** – Safety cut-out (6 A, type B)

**B** – Earth-leakage circuit breaker (30 mA 2-pin, type A)

**C** – 1 x circuit-breaker switch (16 A)

**E** – 2 x DIN rail mounting TS 35

**F** – Equipotential bonding strip

Connect the equipotential bonding strip to the main grounding bar.

# Standard installation

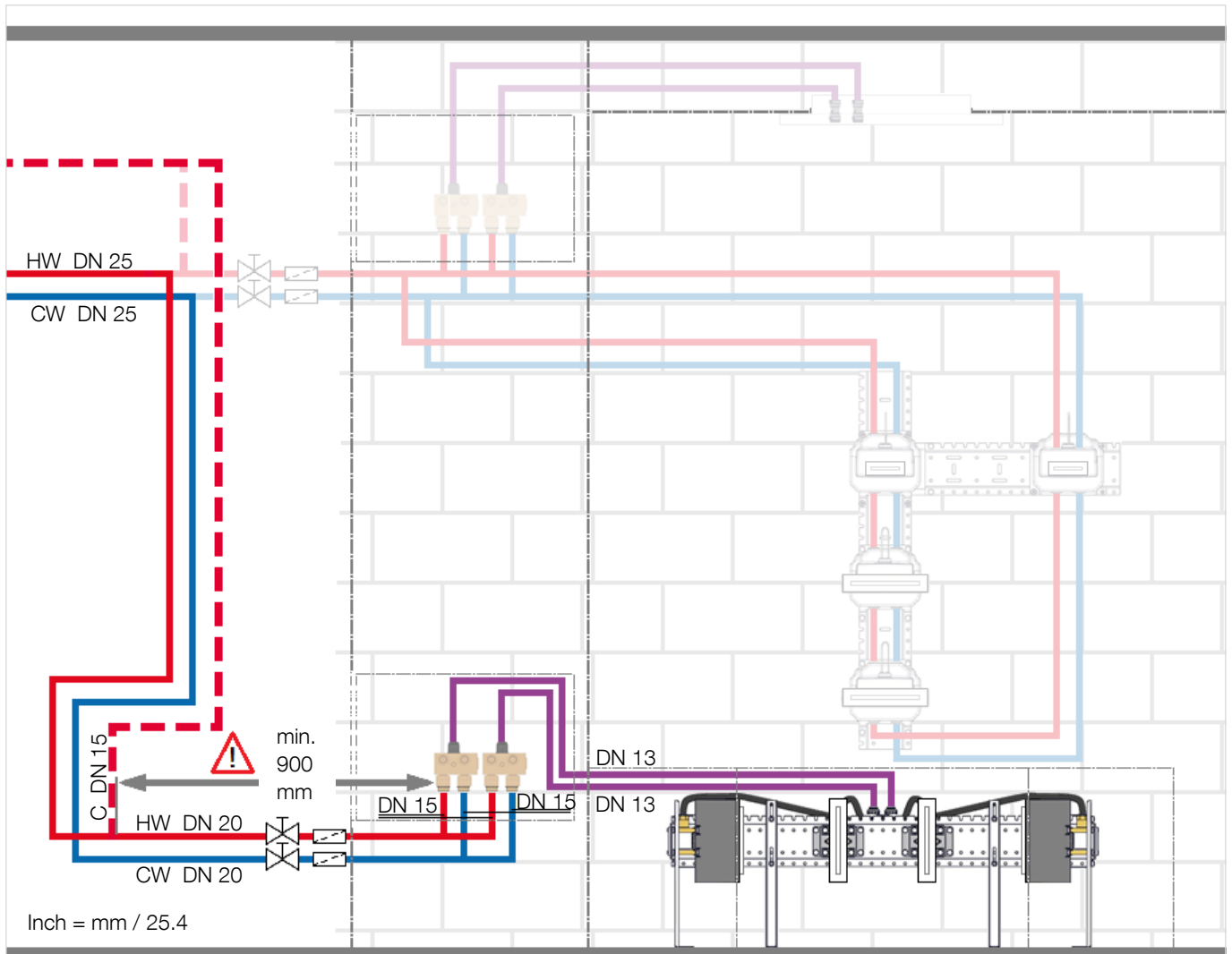

Required nominal diameter (DN) for pipes and fittings:  
 – DN 25 – COMFORT SHOWER<sup>ATT</sup> + LEG SHOWER<sup>ATT</sup>  
 hot and cold water pipe (HW + CW)  
 – DN 20 – LEG SHOWER<sup>ATT</sup>  
 hot and cold water pipe (HW + CW)

Scope of supply:

– DN 13 – LEG SHOWER<sup>ATT</sup> feed pipes

– 900 mm / 2 ft 11-3/8" minimum distance between the circulation pipe connection (C) and the booster plate

The following components for the hot and cold water pipe (HW + CW) must be positioned so that access is possible at all times (accessible for inspection):

- 2 x stop valve (DN 20)
- 2 x strainer (DN 20)



## Schematic diagram

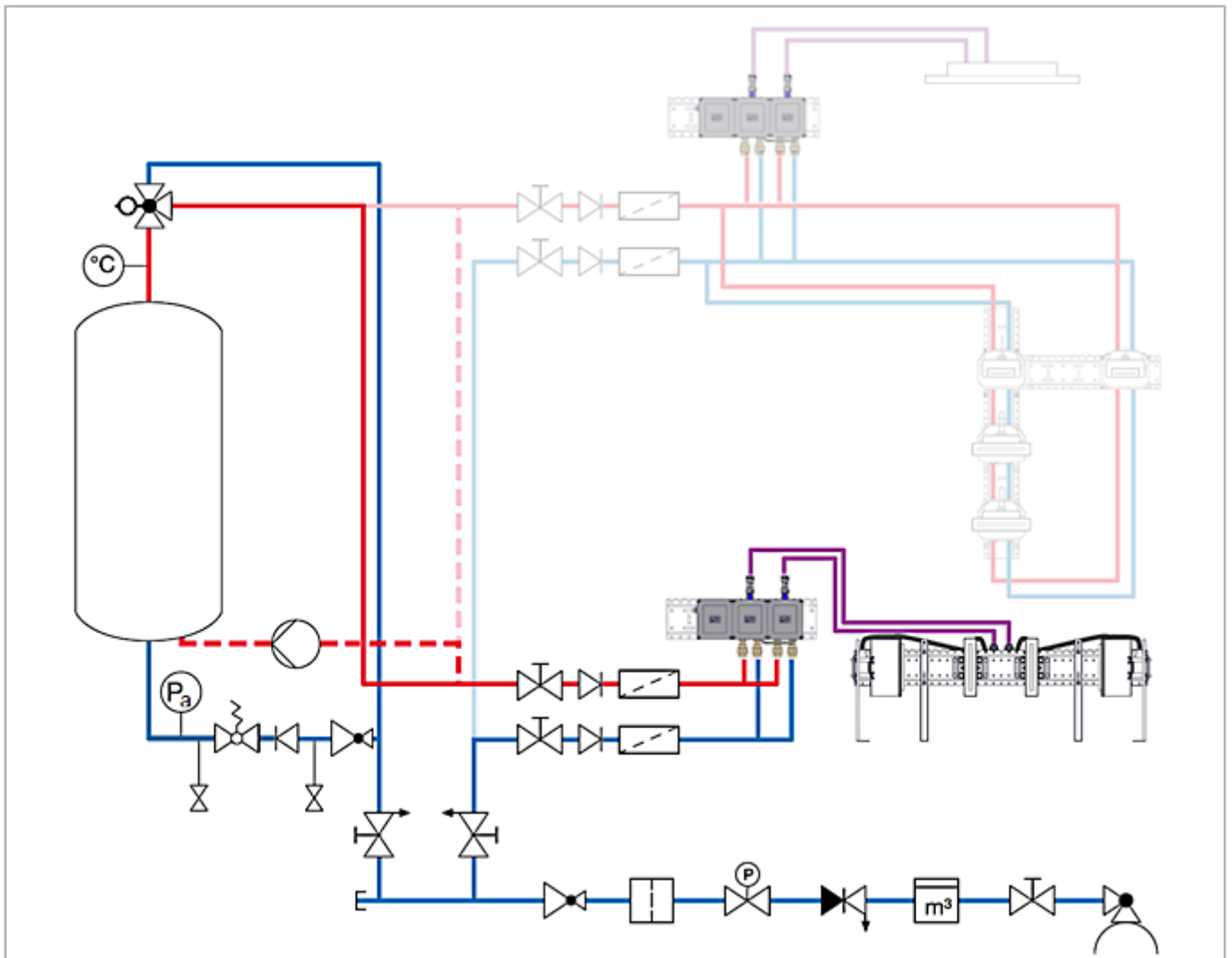

Typical installation under EN 1717.

Key on next page

Please conform to national statutory regulations, where different.

Provided by customer:

- Filter (main pipe)
- Pressure reducing valve (main pipe)

# Key

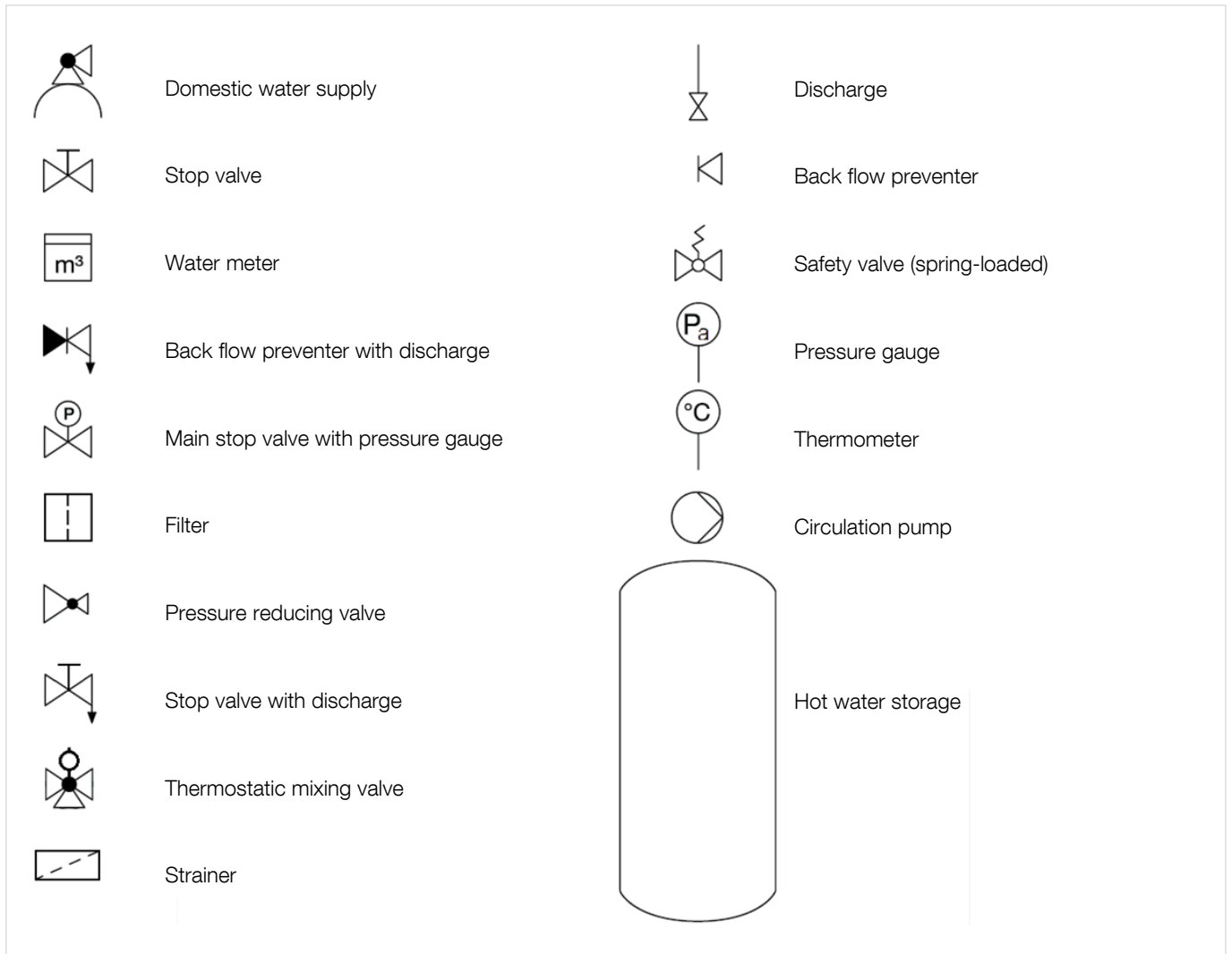

# Plumbing information

## Pipework calculation

The pipework must be calculated in accordance with EN 806-3, DIN 1988-300.

The simultaneous use of all other outlet points must be considered (simultaneity).

Pressure reducing components of the LEG SHOWER<sup>ATT</sup>:

- Stop valve 1.2 kPa / 0.174 psi / 0.012 bar
- Strainer 14 kPa / 2.03 psi / 0.14 bar

Pressure-reducing components provided by the customer:

- Water meter max. 100 kPa / 14.5 psi / 1 bar
- Filter max. 20 kPa / 2.9 psi / 0.2 bar
- Pressure reducing valve (main pipe) see manufacturer's specification
- Water softener, if necessary see manufacturer's specification

Install a speed-controlled pressure booster, if necessary (e. g. in accordance with DIN 1988-500).

## Hot water system

To select the ideal hot water supply – taking additional tapping points and simultaneous use into account – it is essential to assess the demand on an individual basis (e. g. in accordance with DIN 1988-200, DIN 4708-2, DIN 4753-7, VDI 6003).

If the hot water temperature is set to more than 65 °C / 149 °F, a thermostatic water mixer must be installed behind the hot water supply (e. g. for solar heated systems).

If regular disinfection is required, the customer must provide a relevant (manually or automatically operated) means of bypassing the thermostatic water mixer.

## Floor drain

To select the ideal drain – taking the flow rate of the entire installation into account – it is necessary to assess demand on an individual basis. (e. g. in accordance with EN 12056-1/-2, DIN 1986-100).

Drainage capacity / drain connection value [DU value]  
0.6 l/s / 0.2 gps

Recommended drainage capacity / drain connection value [DU value]  
with the COMFORT SHOWER<sup>ATT</sup> 2.4 l/s / 0.6 gps  
Recommended drain pipe size DN 75 / NPS 3"

## Internal plumbing

It is essential for the entire installation to be flushed with clean water (in compliance with the applicable guidelines for flushing).

A flushing report must be prepared (e. g. EN 806-4 / DIN 1988-200).

Flush before fitting the exposed trim parts and commissioning.

It is essential to run a pressure test of the entire installation. For the exact pressure test procedure (preliminary test / main test), based on the material used for the pipes, please see the currently valid directives (EN 806-4, DIN 1988-200, etc.). A test report must be prepared.

# Schematic diagram

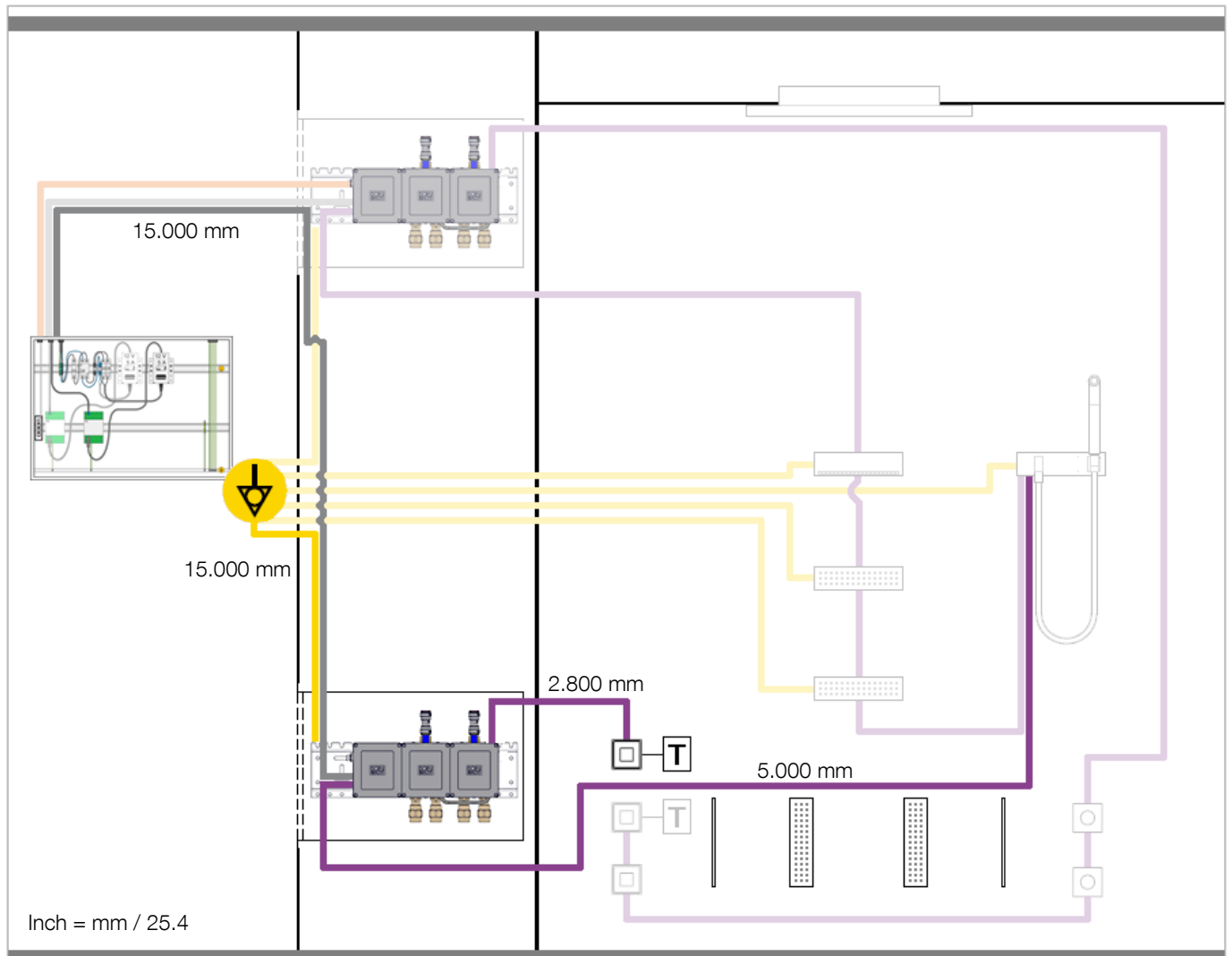

Inch = mm / 25.4

### LEG SHOWER<sup>ATT</sup>

- = cable (12 V DC)
- = VBUS cable
- = equipotential bonding cable (4 mm<sup>2</sup> / AWG 11)
- = equipotential bonding
- = terminator

### COMFORT SHOWER<sup>ATT</sup>

- = cable (12 V DC)
- = Ethernet cable (CAT 7)
- = VBUS cable
- = equipotential bonding cable (4 mm<sup>2</sup> / AWG 11)
- = terminator

The length specifications relate to the condition on delivery.

# Conduits

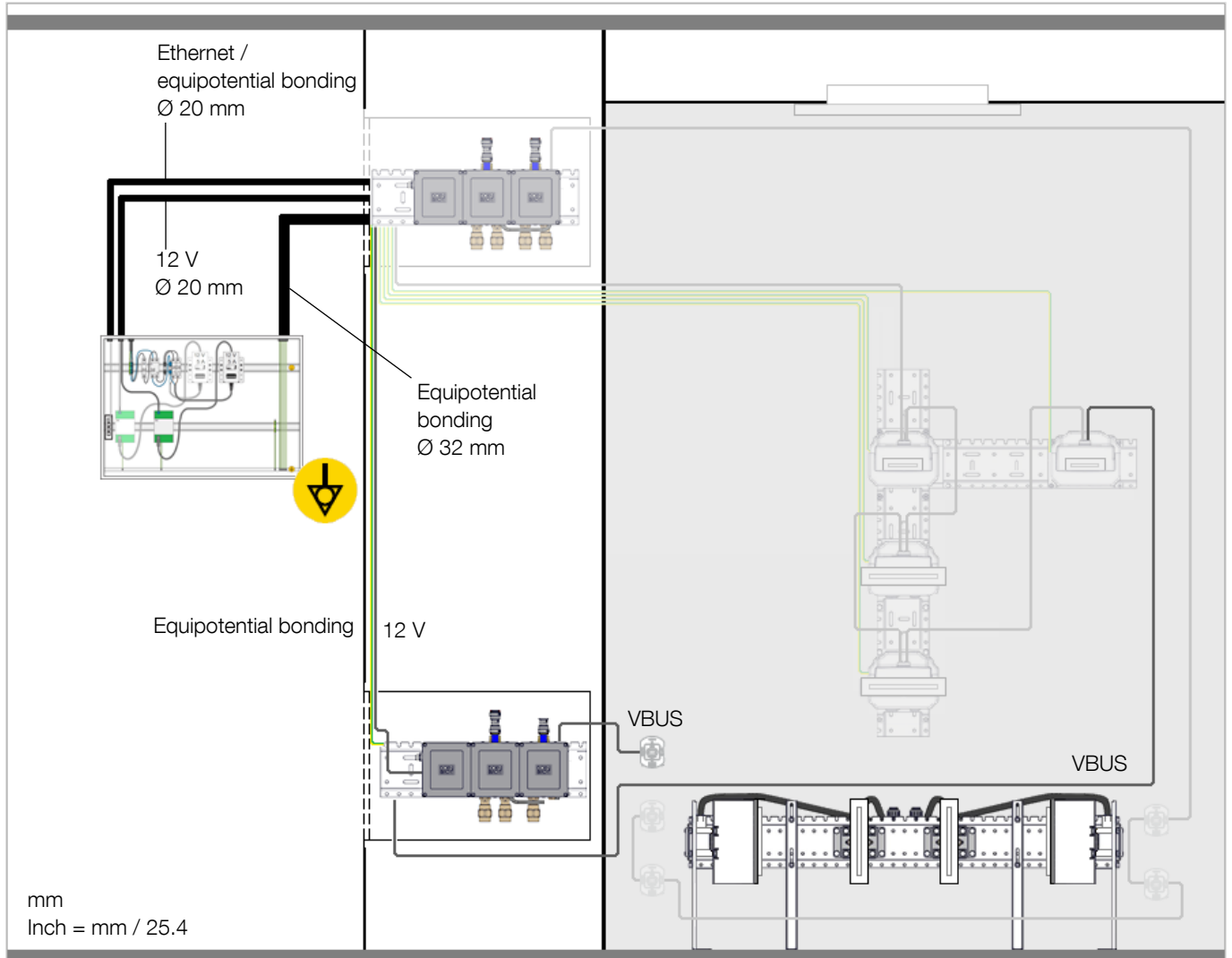

If the cables inside the lightweight wall are routed as far as the shower conduits, there is no need for separate conduits. Do not run the power supply through the same conduit with equipotential bonding or Ethernet.

Provided by customer:

- 1 x conduit Ø 20 mm / Ø 13/4" to max. 12.000 mm / 39 ft 4-3/8" (for the equipotential bonding cable from the fuse box to the booster plate)
- 1 x conduit Ø 20 mm / Ø 3/4" to max. 12.000 mm / 39 ft 4-3/8" (for the power supply from the fuse box to the booster plate)

⚠ Do not roll up excess cable lengths. Shorten the excess cable lengths or fasten them in a meandering pattern.

As part of the cable length is required for connection, the conduits must be correspondingly shorter.

# Fuse box wiring diagram

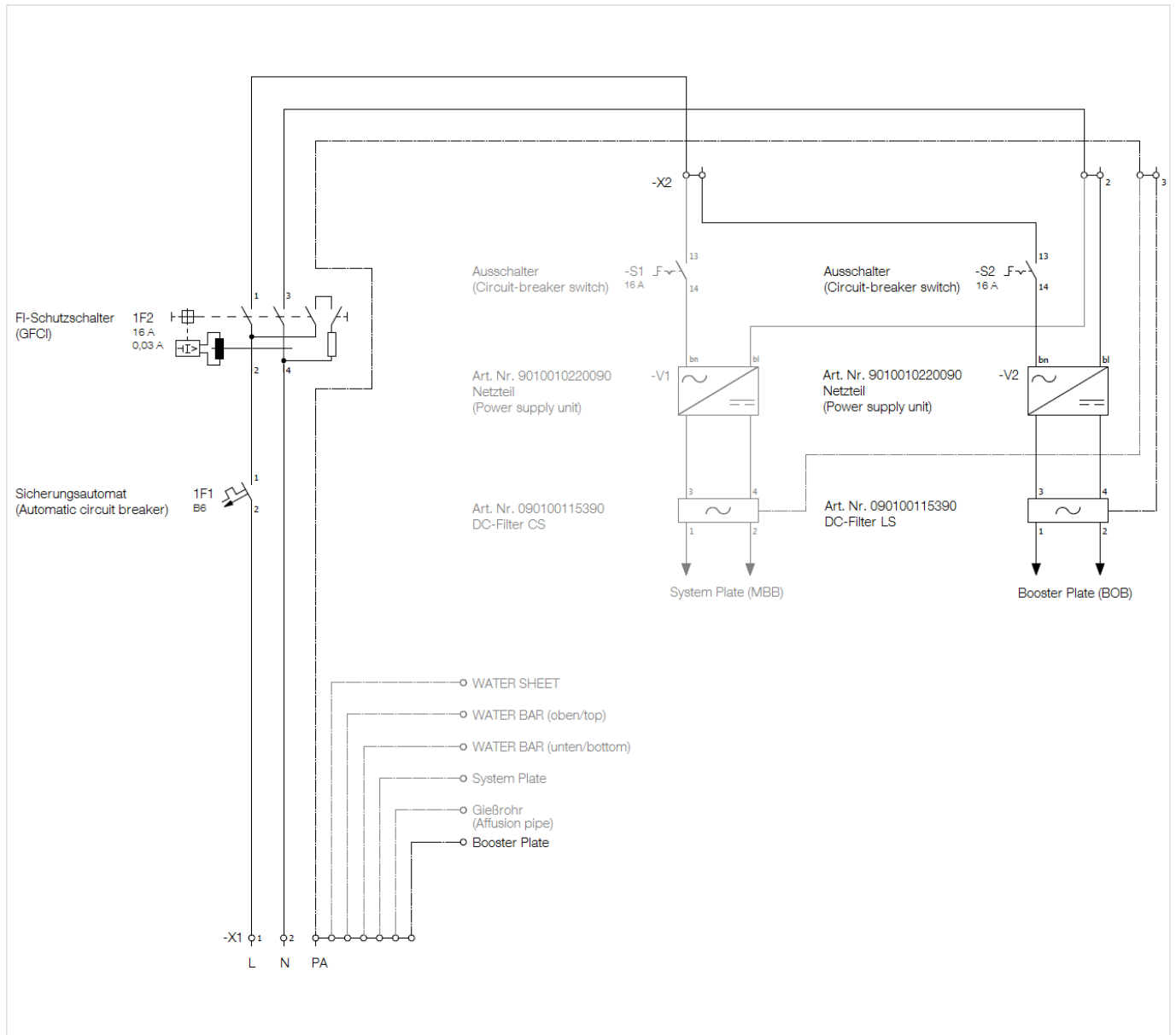

LEG SHOWER<sup>ATT</sup> with COMFORT SHOWER<sup>ATT</sup>

# Electrical information

## Electrical installation

Only connect to the electricity supply when the device is voltage-free.

**⚠** Inexpertly completed electrical installations and electrical installations that are not completed as stipulated in this guide can cause electric shocks which could result in serious injury or even death, as well as damage to property.

The electrical installation must be implemented in accordance with IEC 60364-4-41 and DIN VDE 0100 by a qualified electrician. Please conform to national statutory regulations, where different.

Combine the devices only with original Dornbracht components.

## Equipotential bonding

**⚠** Do not create equipotential bonding over water pipes.

It is essential to use and/or install equipotential bonding cables (4 mm<sup>2</sup> / AWG 11).

### Provided by customer:

- Fuse box in accordance with planning requirements
- Safety cut-out (6 A, type B)
- Earth-leakage circuit breaker (30 mA 2-pin, type A),
- 1 x circuit-breaker switch (16 A)
- 2 x DIN rail mounting TS 35
- Equipotential bonding strip
- Network connection in accordance with TIA 568A, if necessary

## Alternative positions

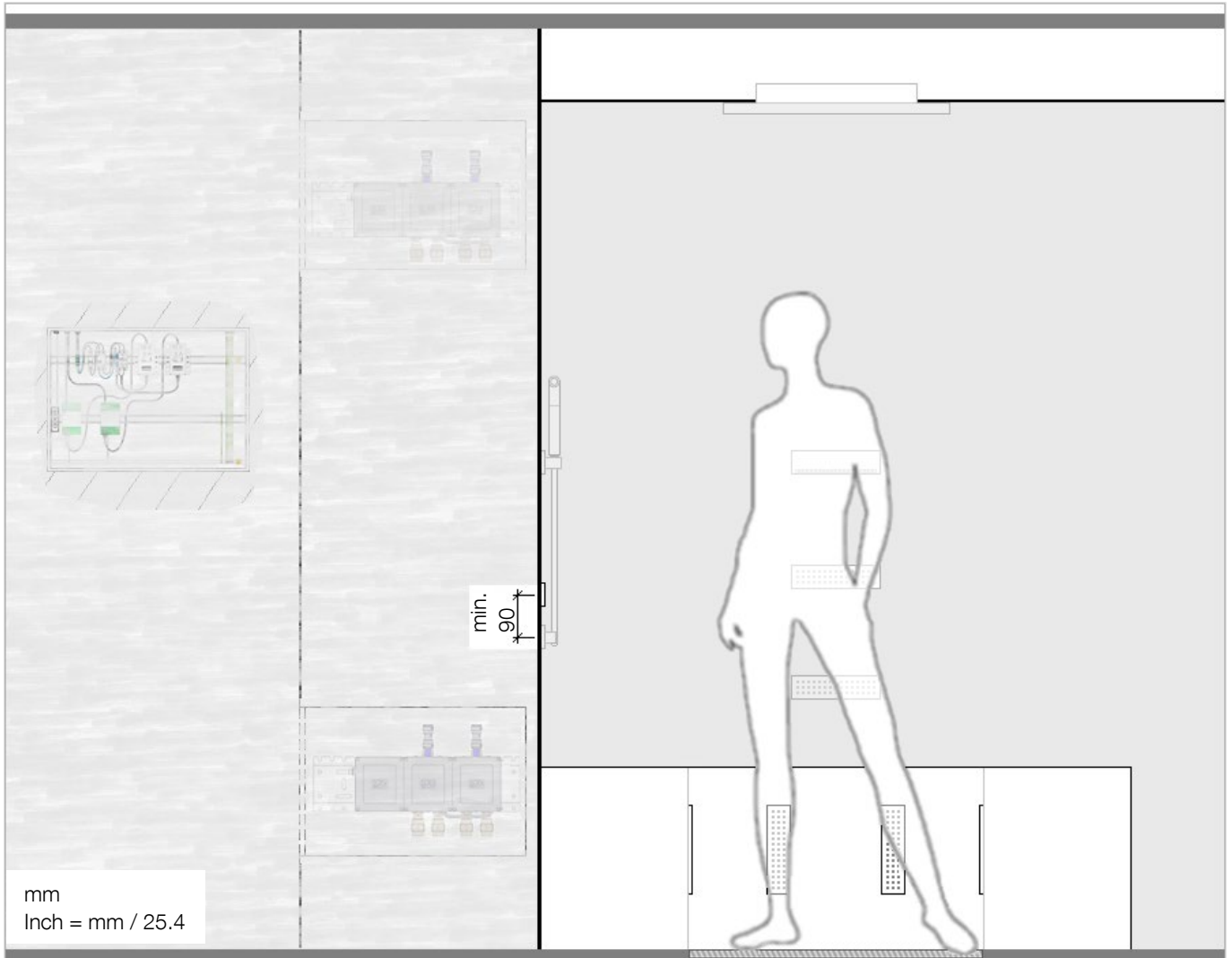

### Important for planning:

- A pre-wall system is essential for the booster plate and LEG SHOWER<sup>ATT</sup>.
- 1,400 mm / 4 ft 7-1/8" maximum height of the closed pre-wall, to allow the concealed rough parts of SMART TOOLS and the VBUS cable to be fitted.
- Installation of the water pipes, cables and conduits must be planned.

- See the schematic diagram on page 20 for the cable lengths
- The VBUS connection of the electrical components (daisy chain) must finish with a terminator.
- No more than 5 components should be connected one after the other in the daisy chain.  
Dornbracht must be consulted in advance about installations that differ from the planning information.
- The total length of the daisy chain must not exceed 30000 mm / 98 ft 5-1/8".



# Leg Shower<sup>ATT</sup>

## LEG SHOWER<sup>ATT</sup> 41 331 979-83:

polished chrome WATER BAR (00),  
polished chrome SMART TOOLS (00)

## LEG SHOWER<sup>ATT</sup> 41 331 979-89:

platinum matt WATER BAR (06),  
platinum matt SMART TOOLS (06)

- Exposed trim parts

### 4x WATER BAR concealed body spray

- WATER BAR cover plate x mm
- 1/2" WATER BAR connector

### 2x eVALVE electronic valve for water temperature and volume adjustment

- Diagnostic capability
- Update capability
- supports thermal disinfection
- automatic scald protection

### 1x electronic control elements (SMART TOOLS)

- 1x Display switch control elements with electronic control for WATER BARS, scenarios, each 60 x 60 mm
- preset temperature and volume
- Button lock for cleaning
- Service displays
- Pause function
- can be updated and networked

Additional planning information for the xGRID installation track can be found in the Symetrics Planning Guide at [www.dornbracht-professional.com](http://www.dornbracht-professional.com).

Dust covers and waterproof packing are included in every concealed rough parts delivery, ex works.

All rough parts with 25 m Ethernet cable

It is obligatory for technical planning, installation and initial commissioning to be accompanied by a certified system partner or by booking a Dornbracht service package

Detailed information on the service package can be found at [www.dornbracht-professional.com](http://www.dornbracht-professional.com).

## LEG SHOWER<sup>ATT</sup> 35 331 979-83:

Concealed rough parts

### 4x WATER BAR wall installation box

- Angle bracket
- attachment set

### 1x concealed rough parts for electronic control elements (SMART TOOLS)

- 1x concealed box for pre-wall installation mounting
- Min. recess depth for SMART TOOLS, 141 mm, hole diameter 56 mm

### 3x xGRID installation tracks incl. connection kit

- 2x installation track 510 x 135 x 12 mm
- 1x installation track 1110 x 135 x 12 mm
- 1x connection kit

Detailed planning information and technical data can be found at [www.dornbracht-professional.com](http://www.dornbracht-professional.com).

# Leg Shower<sup>ATT</sup>

## Concealed rough parts

- A – Concealed rough parts for the LEG SHOWER<sup>ATT</sup>, pre-fitted
- B – 4 x mounting bracket
- C – 2 x feed pipes (DN 13)

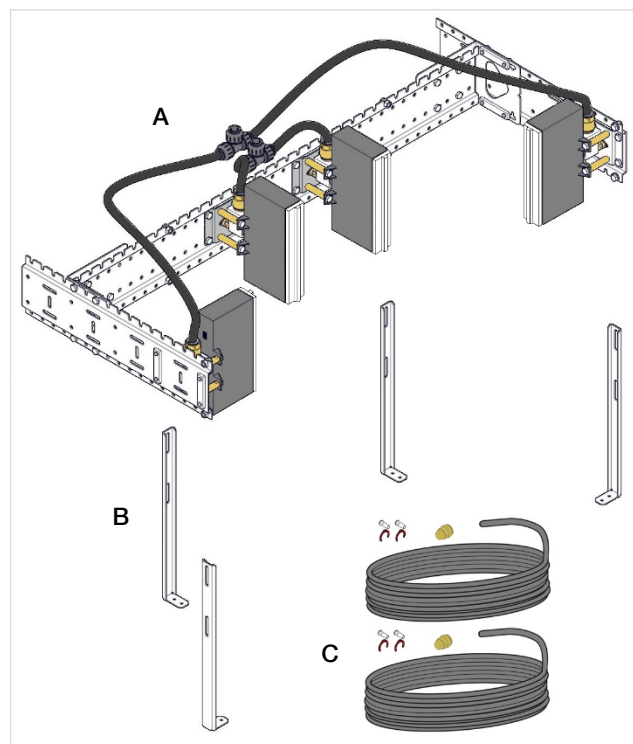

## Exposed trim parts

- D – 4 x WATER BAR

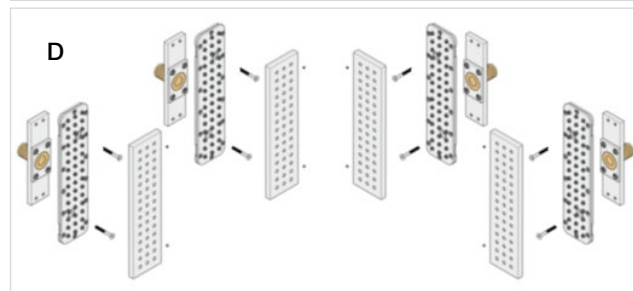

## Booster plate

- E – xGRID track 510 mm
- F – Booster box
- G – 2 x box with eVALVE

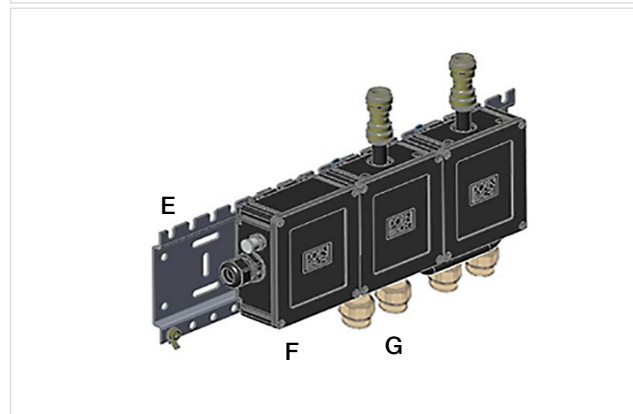

## Control elements

### Concealed rough parts

A – 1 x control element concealed rough parts

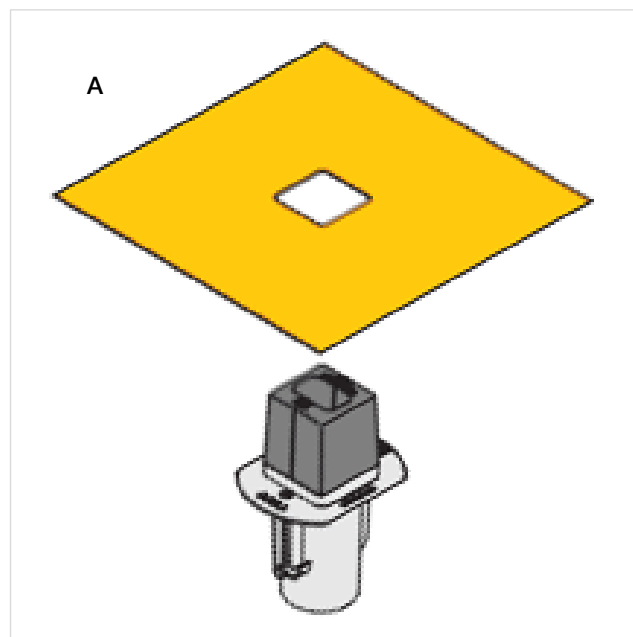

### Exposed trim parts

B – 1 x display switch

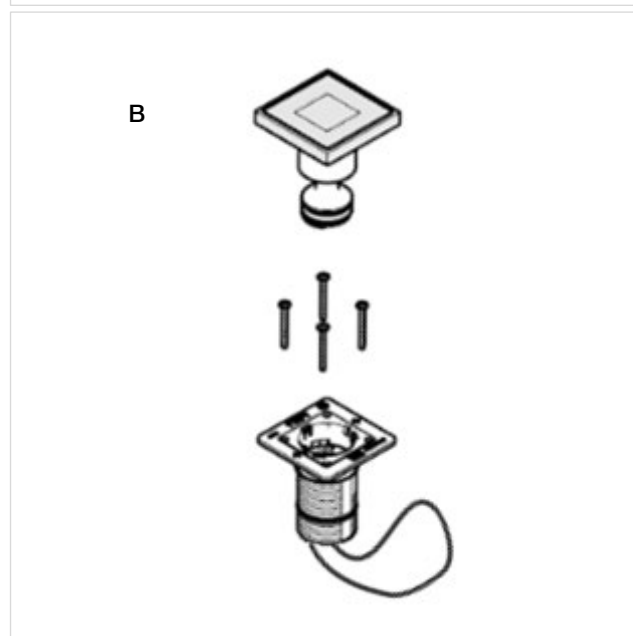

# Miscellaneous

## Internal plumbing

### Concealed rough parts

- A – 2 x stop valve
- B – 2 x strainer
- C – 2 x Y press and flush device

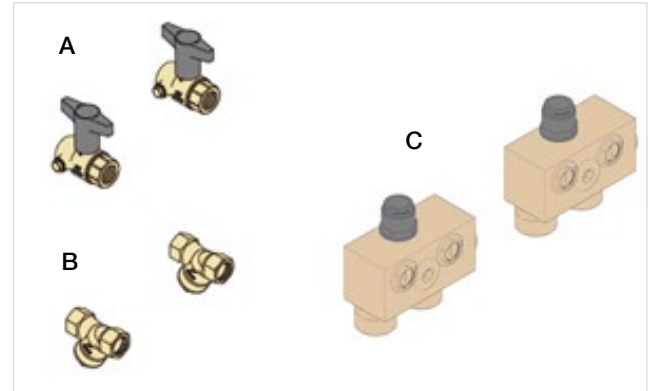

## Electrical installation

### Concealed rough parts

- D – 1 x power supply 12 V DC, 5 A 15.000 mm
- E – 1 x equipotential bonding 4 mm<sup>2</sup>/ AWG 11 15.000 mm
- F – 1 x VBUS 5.000 mm
- G – 1 x VBUS 2.800 mm

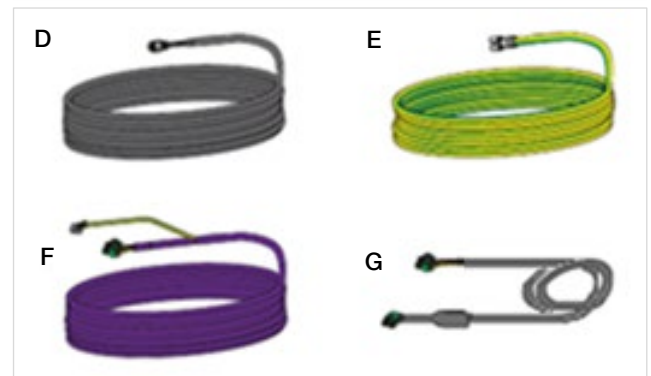

## Exposed trim parts

- H – 1 x DC filter 3 x 5 A
- I – 1 x power supply unit 100 – 240 V AC / 12 V DC, 5 A

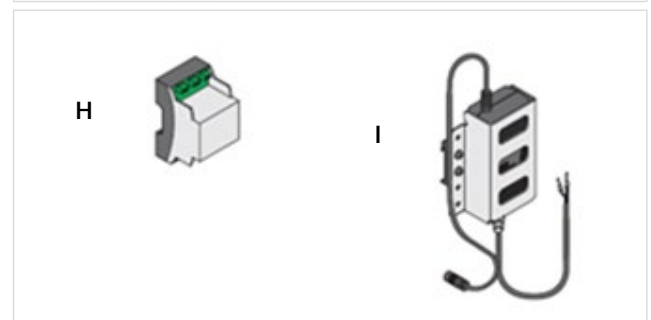

# Required miscellaneous

## Comfort Shower<sup>ATT</sup>

Exposed trim parts 41 321 979-FF

Concealed rough parts 35 321 970 90

See COMFORT SHOWER<sup>ATT</sup> planning guide.



# Technical data

## General

### Weight

- Concealed rough parts 12 kg /26.5 lbs (US)  
 LEG SHOWER<sup>ATT</sup>, pre-fitted
- Booster plate 5 kg / 11 lbs (US)

### Recess depths

- Concealed rough parts 1166 x 510 x 398 mm  
 LEG SHOWER<sup>ATT</sup>, pre-fitted
- Concealed rough parts for WATER BAR min. 102 mm  
 max. 175 mm
- Booster plate 72 mm
- Control elements min. 141 mm
- Drilled hole diameter for concealed box 56 mm

## Electrical data

### Power supply

#### Fuse box power supply unit

- Input voltage 100 – 240 V AC
- Output voltage 12 V DC
- Input frequency 50 – 60 Hz
- Maximum power consumption 60 W
- Power consumption (operation) 6 W

### Booster plate

- Supply voltage 12 V DC
- Protection rating IP X4
- Equipotential bonding 4 mm<sup>2</sup> / AWG 11

### Control elements (display switch)

- Supply voltage 12 V DC
- Protection rating IP X4

## Sanitary engineering data

The product is intrinsically safe in accordance with EN 1717.

The thermostat meets the requirements of EN 1111.

Scald protection (max. factory set temperature)  
 43 °C / 109 °F

## Supply pipe dimensions

Hot/cold water 2 x DN 20 / NPS 3/4"

## Drainage

- Drainage capacity / drain connection value [DU value]  
 0.6 l/s / 0.2 gps
- Recommended drainage capacity / drain connection value [DU value]  
 with the COMFORT SHOWER<sup>ATT</sup> 2.4 l/s / 0.6 gps
- Recommended drain pipe size DN 75 / NPS 3"

To select the ideal drain – taking the flow rate of the entire installation into account – it is necessary to assess demand on an individual basis.

## Maximum flow rate at 300 kPa / 45 psi / 3 bar flow pressure with COMFORT SHOWER<sup>ATT</sup>

- Total 111.5 l/min / 29.5 gpm
- Balance (4:40 mins.) 89 l / 23.5 gal
- De-Stress (5:00 mins.) 88 l / 23.2 gal
- Energize (5:20 mins.) 98 l / 25.9 gal
- Refresh (0:35 mins.) 9 l / 2.4 gal
- Vitalize (2:30 mins.) 43 l / 11.4 gal

## Mark of conformity

CE



# Control elements

Smart Tools



mm

Concealed rough parts for  
SMART TOOLS

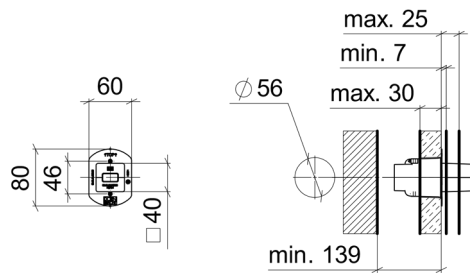

mm

Inch = mm / 25.4



## Europe

DE	Dornbracht Deutschland GmbH & Co.KG Hotline Technische Beratung E-Mail tservice@dornbracht.de  Dornbracht International GmbH E-Mail tservice@dornbrachtgroup.com	Tel. +49 (0)2371 433 480 Fax +49 (0)2371 433 175
BE	Dornbracht E-Mail mail@dornbrachtgroup.be	Tel. +32 (053) 81 02 78 (Vlaams) +32 (053) 81 02 79 (French) Fax +32 (053) 80 47 41
CH	Dornbracht Schweiz AG E-Mail mail@dornbrachtgroup.ch	Tel. +41 (0) 62 787 20 30 Fax +41 (0) 62 787 20 40
CZ, SK	Agentura Kramárová E-Mail mkramar@email.cz	Mob. +420 724 207 528
ES, PT	Dornbracht España S.L. E-Mail mail@dornbrachtgroup.es	Tel. +34 93-272 391 0 Fax +34 93-272 391 3
FR	Dornbracht France SARL E-Mail mail@dornbrachtgroup.fr	Tel. +33 (0) 1 40 21 10 70 Fax +33 (0) 1 40 21 37 01
HU	Z-A Design Stúdió Kft. E-Mail dornbracht@zadesign.hu	Tel. +36 70 77 50 954
IT	Dornbracht Italia s.r.l. E-Mail mail@dornbrachtgroup.it	Tel. +39 02 81 83 43 1 Fax +39 02 81 83 43 215
LT, EE, LV	Arunas Jazukevicius E-Mail arunas.jazukevicius@burgbad-baltics.com	Tel. +370 686 303 13 Fax +370 37 202767
NL	Dornbracht Nederland B.V. E-Mail mail@dornbrachtgroup.nl	Tel. +31 (0) 10 52 43 400 Fax +31 (0) 10 52 43 410
PL	Honorata Broniowska E-Mail: biuro@dornbrachtgroup.pl	Tel. +48 (0) 95-728 261 7 Mob. +48 (0) 602471319
RO, BG, MD	Reallize Consult SRL E-Mail dornbracht@reallize.ro	Tel. +40 21 528 03 91 Mob. +40 722 654 654 Fax +40 21 528 03 90
RU, BY, KZ	OSA GmbH & Co. KG E-Mail osa@o-s-a.de	Tel. +7 (499) 241 8259
DK, SE, NO, FI, IS	Dornbracht Nordic A/S E-Mail mail@dornbrachtgroup.dk	Tel. +45 50 84 54 00
SRB, BIH, MNE, MK, HR	DOZEN Stars d.o.o. E-Mail nenadkop@yahoo.com E-Mail zoja.jovicevic@yahoo.com	Tel. +381 (11) 6555120, 6555119, 6555118 Fax +381 (11) 22 83 966
AM, AZ, GE, GR, KG, TJ, TR, TM, UZ, Northern Cyprus	Dornbracht Turkey/Central Asia E-Mail mail@dornbrachtgroup.com.tr	Tel. +90 (0) 212 284 9495 Fax +90 (0) 212 284 0023
UA	Lesia Khelemendyk E-Mail office@helena.com.ua	Tel. +38 (0) 44-244 7682 Fax +38 (0) 44-244 7682
UK, IE	Dornbracht UK Ltd. E-Mail mail@dornbrachtgroup.co.uk	Tel. +44 (0) 2476-717 129 Fax +44 (0) 2476-718 907
<b>Central Europe</b>		
AT	Dornbracht Austria GmbH E-Mail mail@dornbrachtgroup.at	Tel. +43 (0) 2236-677360 Fax +43 (0) 2236-677360 20

**Americas**

US, CA, Central America, South America	Dornbracht Americas Inc. E-Mail <a href="mailto:dornbrachtam@dornbrachtgroup.com">dornbrachtam@dornbrachtgroup.com</a> E-Mail <a href="mailto:technicalservice@dornbracht.com">technicalservice@dornbracht.com</a>	Tel. +1 800-774-1181 +1 770-564-3599 Fax +1 800-899-8527
Mexico	German Concepts S.A. de C.V. E-Mail <a href="mailto:rmijares@germanconcepts.com.mx">rmijares@germanconcepts.com.mx</a>	Tel. +52 (55) 53 43 84 50 Fax +52 (55) 53 43 90 97
	Dornbracht Americas Inc.	Tel. +1 800-774-1181 +1 770-564-3599 Fax +1 800-899-8527

**Asia Pacific**

HK/MAC, JP, KR, TW, NZ, AUS	Dornbracht Asia Pacific Ltd. E-Mail <a href="mailto:mail@dornbrachtgroup.hk">mail@dornbrachtgroup.hk</a>	Tel. +852 2505 6254 Fax +852 2505 9722
SG, ML, ID, PH, TH, VN	Dornbracht South East Asia Pte. Ltd. E-Mail <a href="mailto:mail@dornbrachtgroup.sg">mail@dornbrachtgroup.sg</a>	Tel. +65 6823 6813
CN	Dornbracht (Shanghai) Commercial Ltd. E-Mail <a href="mailto:mail@dornbrachtgroup.com.cn">mail@dornbrachtgroup.com.cn</a>	Tel. +86 (0) 21-6360 6930 +86 (0) 21-5150 6775 Fax +86 (0) 21-6361 4155
IN	Dornbracht India Private Ltd. E-Mail <a href="mailto:mail@dornbrachtgroup.in">mail@dornbrachtgroup.in</a>	Tel. +91 22 26853900 +91 22 26853912 Fax +91 22 26853900

**Middle East**

AE, BH, EG, IQ, IR, JO, KW, LB, OM, PK, QA, SA, SY, YE	Dornbracht International GmbH - Rep. Office E-Mail <a href="mailto:DornbrachtME@dornbrachtgroup.com">DornbrachtME@dornbrachtgroup.com</a>	Tel. +971 4 380 6611 Fax +971 4 380 6606
LB	Naji Kanafani & Fils E-Mail <a href="mailto:info@kanafani.com.lb">info@kanafani.com.lb</a>	Tel. +961 1 307 400 Mob. +961 3 251 630 Fax +961 1 307 403

**South Africa**

ZA	Siobhan Thomas E-Mail <a href="mailto:Siobhan@dornbracht.co.za">Siobhan@dornbracht.co.za</a>	Tel. +27 215 117 888
----	---	----------------------

**West Africa**

BJ, CI, CM, GH, GM, GA, SN	Mr. Amine Moghrabi E-Mail <a href="mailto:amine_mak@idm.net.lb">amine_mak@idm.net.lb</a> E-Mail <a href="mailto:amine_mak@hotmail.com">amine_mak@hotmail.com</a>	Mob. +225 05 55 38 38 +961 3 29 02 49
----------------------------	--	--

Aloys F. Dornbracht GmbH & Co. KG Armaturenfabrik  
Köbbingser Mühle 6, D-58640 Iserlohn  
Tel. +49(0)2371 433-0, Fax +49(0)2371 433-232  
mail@dornbracht.de, dornbracht.com

Dornbracht Group  
Premium Solutions for Interior Architecture