

PROGRAMMA MISCELAZIONE BAGNO
BATH MIXING PROGRAM
PROGRAMME DU MITIGEUR POUR LA SALLE DE BAIN
BAD-MISCHUNGSPROGRAMM
PROGRAMA MEZCLADORES BAÑO
ПРОГРАММА СМЕСИТЕЛЕЙ ДЛЯ ВАННОЙ
ΑΝΑΜΙΚΤΙΚΟ ΠΡΟΓΡΑΜΜΑ ΜΠΑΝΙΟΥ
浴室混水产品

ARCHITECTURAL WELLNESS

Art. 61112

Art. 61114

GESSI 

Gessi SpA - Parco Gessi

13037 Serravalle Sesia (Vercelli) - Italy

Phone +39 0163 454111 - Facsimile +39 0163 459273

www.gessi.com - gessi@gessi.it

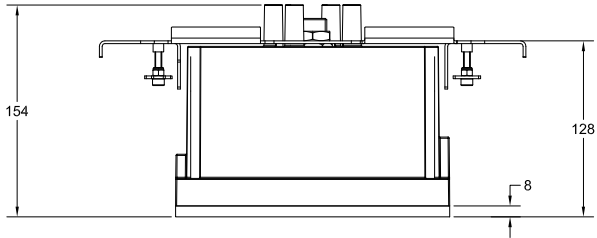
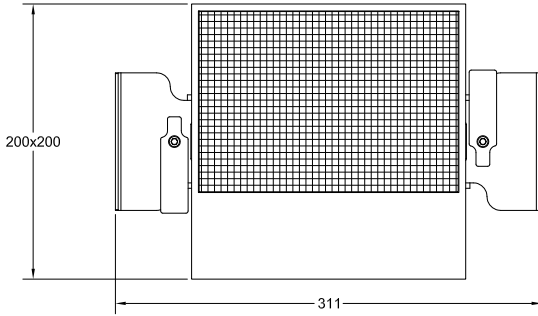



Specifiche generali

- Temperatura d'esercizio: da 10°C a 60°C
- Tensione di alimentazione: 12V dc
- Classe di protezione componenti elettriche: IP64
- Potenza sonora cassa audio: 20 W
- Impedenza nominale: 4 Ohm

General specifications

- Operating temperature: from 10°C to 60°C
- Power supply voltage: 12V dc
- Electrical components protection class: IP64
- Sound box power: 20 W
- Nominal impedance: 4 Ohm

Spécifications générales

- Température d'exercice : de 10°C à 60°C
- Tension d'alimentation : 12V dc
- Classe de protection composants électriques : IP64
- Puissance sonore enceinte audio : 20 W
- Impédance nominale : 4 Ohm

Allgemeine Spezifikation

- Betriebstemperatur: von 10°C bis 60°C
- Versorgungsspannung: 12V dc
- Schutzart der elektrischen Bestandteile: IP64
- Schalleistung des Lautsprechers: 20 W
- Nominale Impedanz: 4 Ohm

Especificaciones generales

- Temperatura de ejercicio: de 10°C a 60°C
- Tensión de alimentación: 12V dc
- Clase de protección componentes eléctricos: IP64
- Potencia sonora caja audio: 20 W
- Impedancia nominal: 4 Ohmios

Общие характеристики

- Диапазон рабочих температур: от 10°C до 60°C
- Напряжение питания: 12 В DC
- Класс защиты электрических компонентов: IP64
- Звуковая мощность аудио колонки: 20 Вт
- Номинальное сопротивление: 4 Ом

Γενικές προδιαγραφές

- Θερμοκρασία λειτουργίας: από 10°C έως 60°C
- Τάση τροφοδοσίας: 12V dc
- Κλάση προστασίας ηλεκτρικών εξαρτημάτων: IP64
- Ηχητική ισχύς ηχείου audio: 20 W
- Ονομαστική σύνθετη αντίσταση: 4 Ohm

一般规格

- 运行温度: 10° C到60° C
- 电源电压: 12V dc
- 电气部件防护等级: IP64
- 音箱功率: 20 W
- 公称阻抗: 4 Ohm



Le caratteristiche generali del sistema "Architectural Wellness" sono indeterminate sull'etichetta dell'elettronica presente negli articoli 61201-61203 (vedi immagine sotto).

The general features of the "Architectural Wellness" system are shown in the electronics identification plate of the items 61201 - 61203 (see picture below).

Les caractéristiques générales du système "Architectural Wellness" sont indiquées sur la plaque d'identification de l'électronique des articles 61201-61203 (voir image dessous).

Die allgemeinen Eigenschaften des Systems "Architectural Wellness" sind auf dem Etikett der Elektronik identifiziert, die sich in den Artikeln 61201-61203 befinden (siehe nachfolgende Abbildung).

Las características generales del sistema "Architectural Wellness" se indican en la placa de identificación de la electrónica de los artículos 61201 - 61203 (ver imagen a continuación).

Основные характеристики системы "Architectural Wellness" указываются в идентификационной табличке электронных компонентов изделий 61201 - 61203 (см. нижеупомянутый рисунок).

Τα γενικά χαρακτηριστικά του συστήματος "Architectural Wellness" προσδιορίζονται στην ετικέτα του ηλεκτρονικού μέρους που υπάρχει στα προϊόντα 61201-61203 (βλέπε παρακάτω εικόνα).

"Architectural Wellness" 系统的一般特征可以从货号61201-61203产品上电子器件的标签上找到（参见下图）

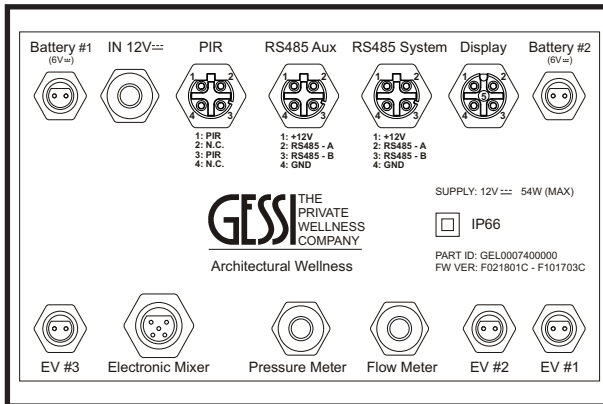



Art. 61112

A

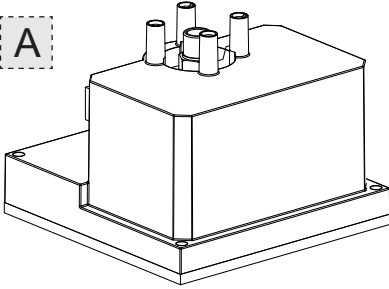

C

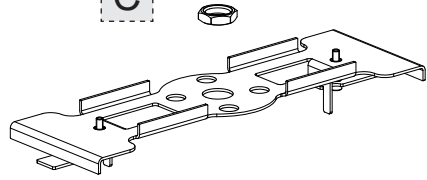

B

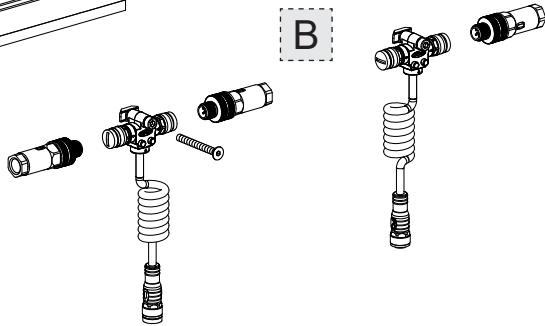

Art. 61114

A

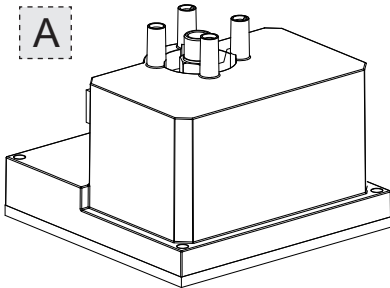

C

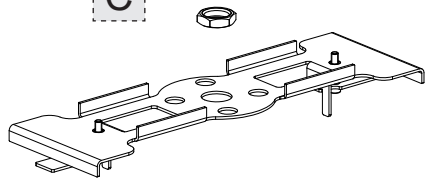

B

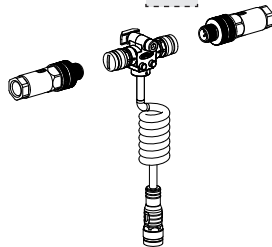



Contenuto della confezione:

- A - Modulo cromoterapia
- B - Componenti elettrici
- C - Staffa di centraggio

Package content:

- A - Chromotherapy module
- B - Electrical components
- C - Centring bracket

Contenu de l'emballage:

- A - Module chromothérapie
- B - Composants électriques
- C - Étrier de centrage

Inhalt der Verpackung:

- A - Farbtherapie-modul
- B - Elektrische Bestandteile
- C - Zentrierungsbügel

Contenido de la caja:

- A - Módulo cromoterapia
- B - Componentes eléctricos
- C - Brida de centrado

Содержимое упаковки:

- A - Модуль хромотерапии
- B - Электрические компоненты
- C - Центрирующая скоба

Περιεχόμενο συσκευασίας:

- A - Στοιχείο χρωματοθεραπείας
- B - Ηλεκτρικά εξαρτήματα
- C - Σφιγκτήρας κεντραρίσματος

包装内含:

- A - 色疗模块
- B - 电气部件
- C - 对中架



CASE n°1

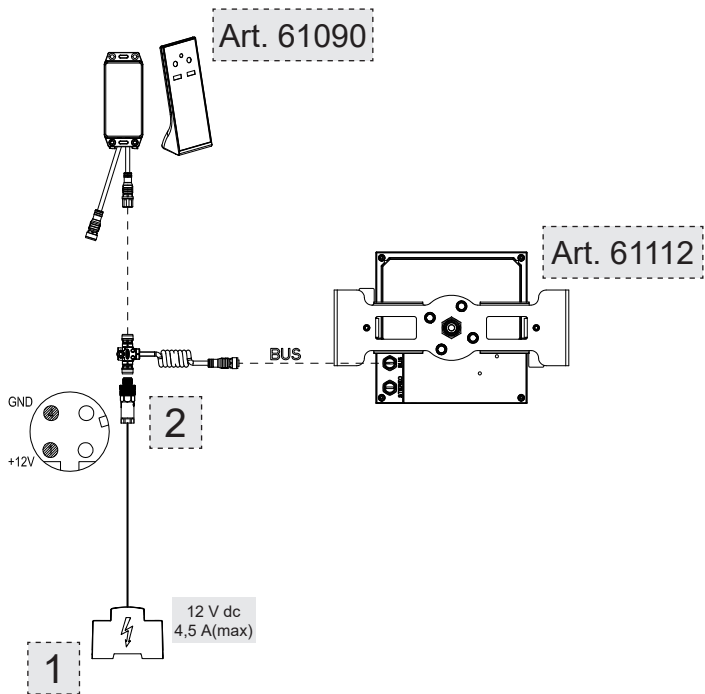



CASE n°2

Art. 61114

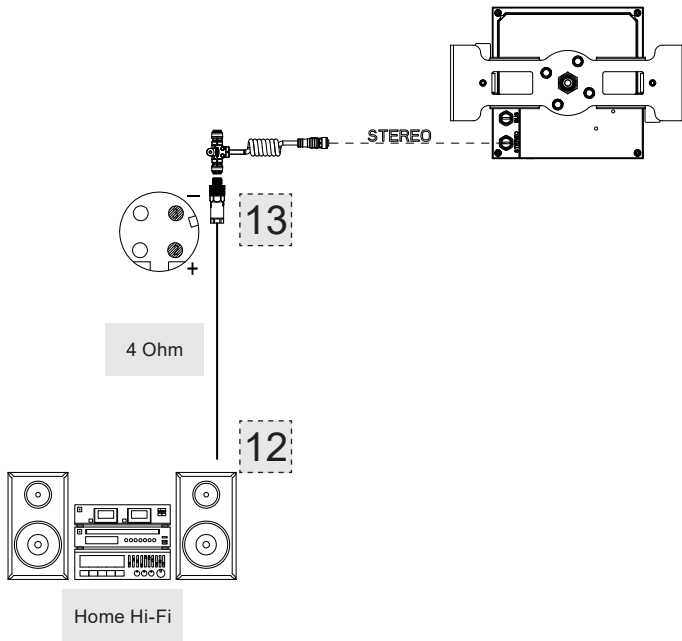



CASE n°3

Art. R5263

Art. 61090

Art. 61112

Art. 61108

GND
+12V

12 V dc
4,5 A(max)

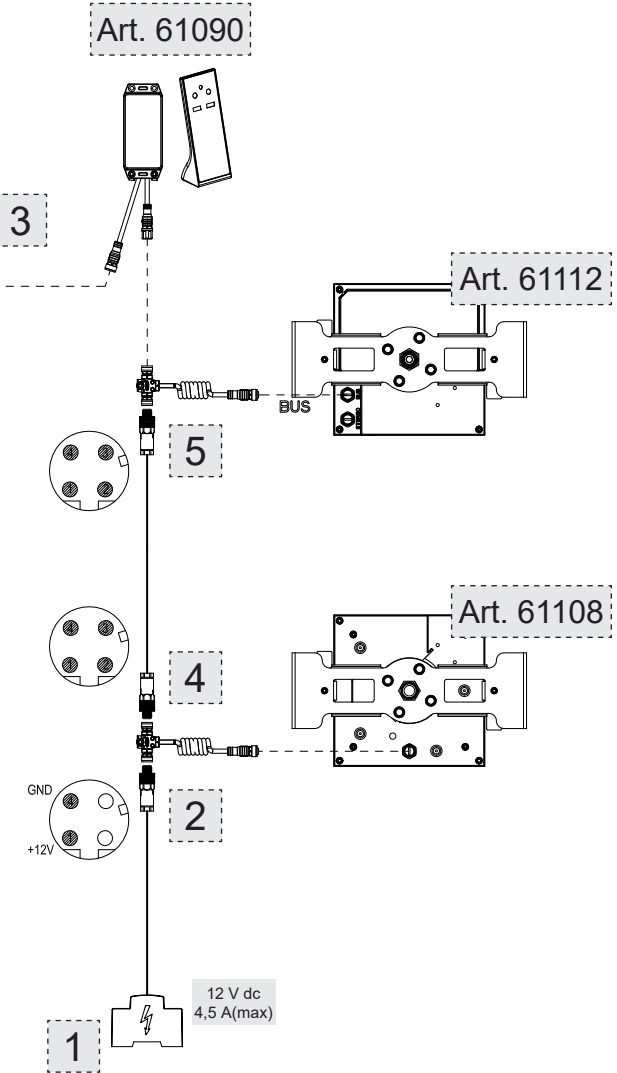



CASE n°5

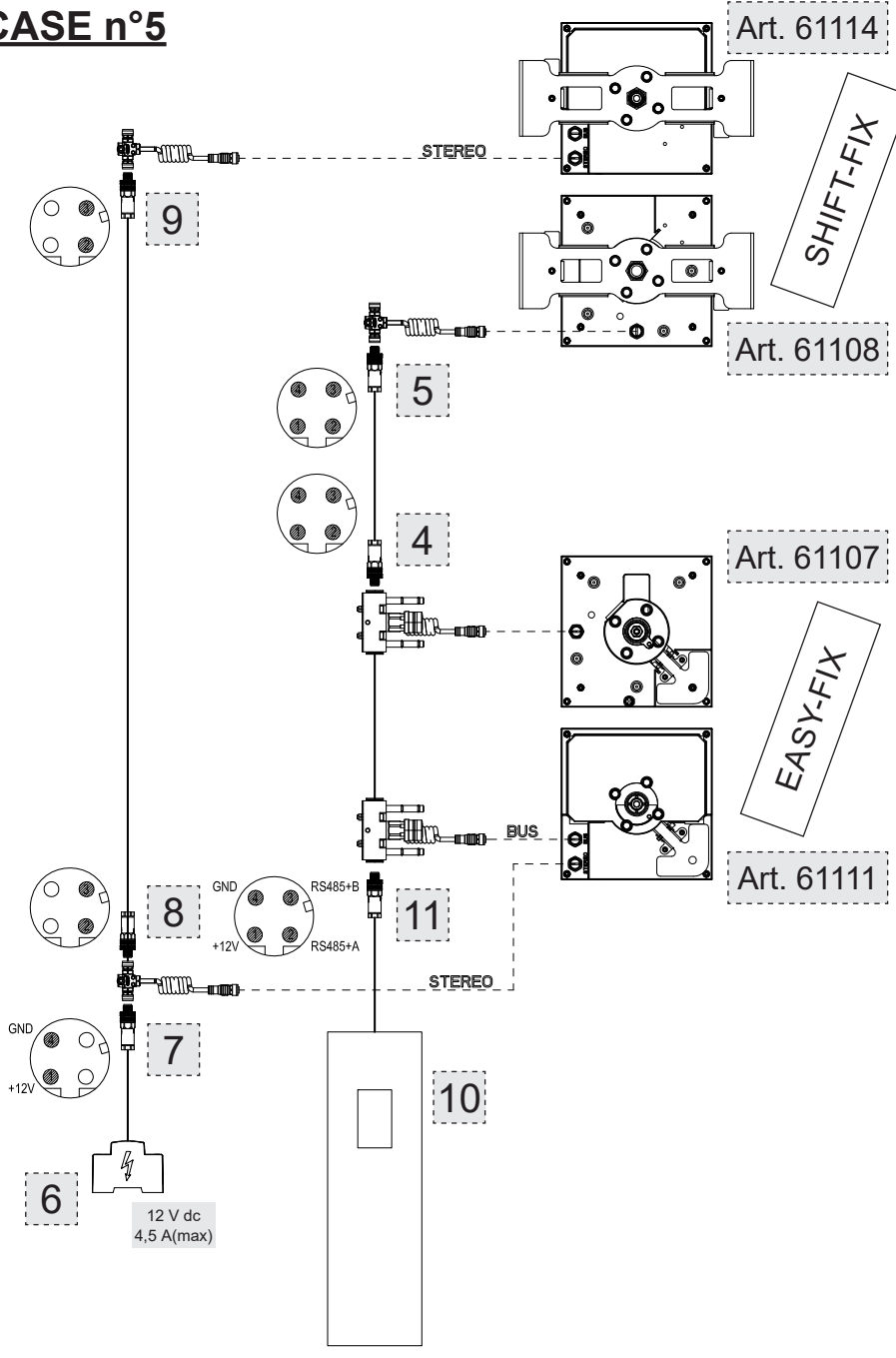



DATI PER COLLEGAMENTI ELETTRICI

- **Collegamento tra 1-2 / 6-7 / 8-9 / 12-13**

Lunghezza max = 8 m

Poli = 2

Sezione = 20-22 AWG

Diametro cavo = 4+6mm (PG7)

- **Collegamento tra R5263-3**

Lunghezza max = 10 m

Poli = 2

Sezione = 20 AWG

Diametro cavo = 4+6mm

- **Collegamento tra 4-5 / 10-11**

Lunghezza max = 8 m

Poli = 4

Sezione = 20-22 AWG

Diametro cavo = 4+6mm (PG7)

ELECTRICAL CONNECTIONS DATA

- **Connection between 1-2 / 6-7 / 8-9 / 12-13**

Length max = 8 m

Poles = 2

Section = 20-22 AWG

Cable diameter: 4+6 mm (PG7)

- **Connection between R5263-3**

Length max = 10 m

Poles = 2

Section = 20 AWG

Cable diameter: 4+6 mm

- **Connection between 4-5 / 10-11**

Length max = 8 m

Poles = 4

Section = 20-22 AWG

Cable diameter: 4+6 mm (PG7)

DONNEES POUR CONNEXIONS ÉLECTRIQUES

- **Connexion entre 1-2 / 6-7 / 8-9 / 12-13**

Longueur max = 8 m

pôles = 2

Section = 20-22 AWG

Diamètre câble : 4+6 mm (PG7)

- **Connexion entre R5263-3**

Longueur max = 10 m

pôles = 2

Section = 20 AWG

Diamètre câble : 4+6 mm

- **Connexion entre 4-5 / 10-11**

Longueur max = 8 m

pôles = 4

Section = 20-22 AWG

Diamètre câble : 4+6 mm (PG7)



DATEN BEZÜGLICH DER ELEKTRISCHEN ANSCHLÜSSE

- **Anschluss zwischen 1-2 / 6-7 / 8-9 / 12-13**

Maximale Länge = 8 m

Pole = 2

Querschnitt = 20-22 AWG

Kabeldurchmesser: 4+6 mm (PG7)

- **Anschluss zwischen R5263-3**

Maximale Länge = 10 m

Pole = 2

Querschnitt = 20 AWG

Kabeldurchmesser: 4+6 mm

- **Anschluss zwischen 4-5 / 10-11**

Maximale Länge = 8 m

Pole = 4

Querschnitt = 20-22 AWG

Kabeldurchmesser: 4+6 mm (PG7)

DATOS PARA LAS CONEXIONES ELÉCTRICAS

- **Conexión entre 1-2 / 6-7 / 8-9 / 12-13**

Largo máx. = 8 m

Polos = 2

Sección = 20-22 AWG

Diámetro cable: 4+6 mm (PG7)

- **Conexión entre R5263-3**

Largo máx. = 10 m

Polos = 2

Sección = 20 AWG

Diámetro cable: 4+6 mm

- **Conexión entre 4-5 / 10-11**

Largo máx. = 8 m

Polos = 4

Sección = 20-22 AWG

Diámetro cable: 4+6 mm (PG7)

ДАННЫЕ ДЛЯ ЭЛЕКТРИЧЕСКИХ СОЕДИНЕНИЙ

- **Соединение между 1-2 / 6-7 / 8-9 / 12-13**

Макс. длина = 8 м

Полюсы = 2

Сечение = 20-22 AWG

Диаметр кабеля: 4+6 мм (PG7)

- **Соединение между R5263-3**

Макс. длина = 10 м

Полюсы = 2

Сечение = 20 AWG

Диаметр кабеля: 4+6 мм

- **Соединение между 4-5 / 10-11**

Макс. длина = 8 м

Полюсы = 4

Сечение = 20-22 AWG

Диаметр кабеля: 4+6 мм (PG7)



ΣΤΟΙΧΕΙΑ ΓΙΑ ΗΛΕΚΤΡΙΚΕΣ ΣΥΝΔΕΣΕΙΣ

- **Σύνδεση μεταξύ 1-2 / 6-7 / 8-9 / 12-13**

Μήκος max = 8 m

Πόλοι = 2

Διατομή = 20-22 AWG

Διάμετρος καλωδίου: 4+6 mm (PG7)

- **Σύνδεση μεταξύ R5263-3**

Μήκος max = 10 m

Πόλοι = 2

Διατομή = 20 AWG

Διάμετρος καλωδίου: 4+6 mm

- **Σύνδεση μεταξύ 4-5 / 10-11**

Μήκος max = 8 m

Πόλοι = 4

Διατομή = 20-22 AWG

Διάμετρος καλωδίου: 4+6 mm (PG7)

电气连接数据

- **1-2 / 6-7 / 8-9 / 12-13之间的连接**

最大长度= 8 m

芯数 = 2

截面积 = AWG20-22

电线直径 4-6 mm (PG7)

- **R5263-3之间的连接**

最大长度= 10 m

芯数 = 2

截面积 = AWG20

电线直径 4-6 mm

- **4-5 / 10-11 之间的连接**

最大长度= 8 m

芯数 = 4

截面积 = AWG20-22

电线直径 4-6 mm (PG7)



Fig. 1A

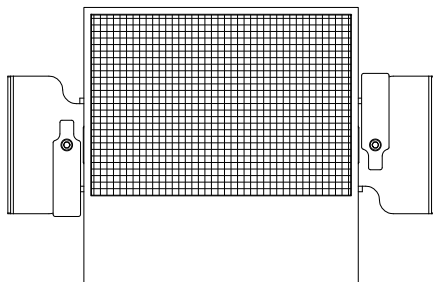
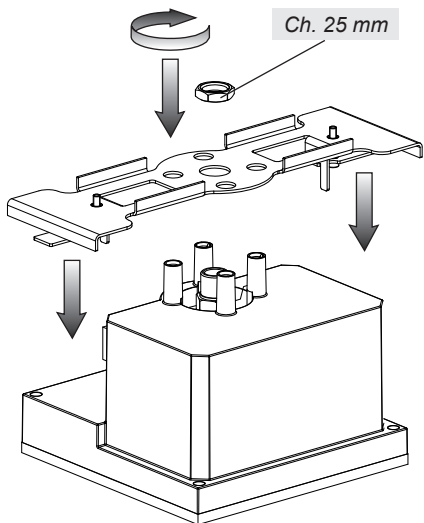

Fig. 1B

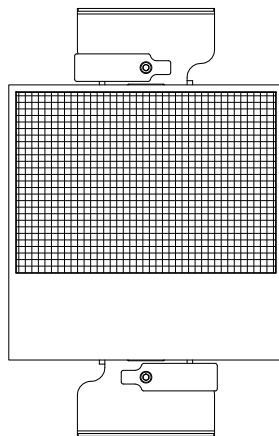
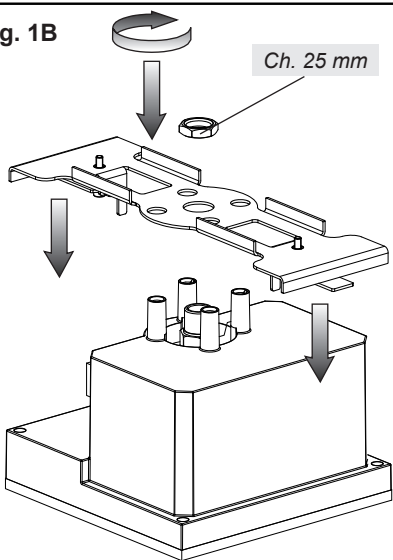



Fig. 2

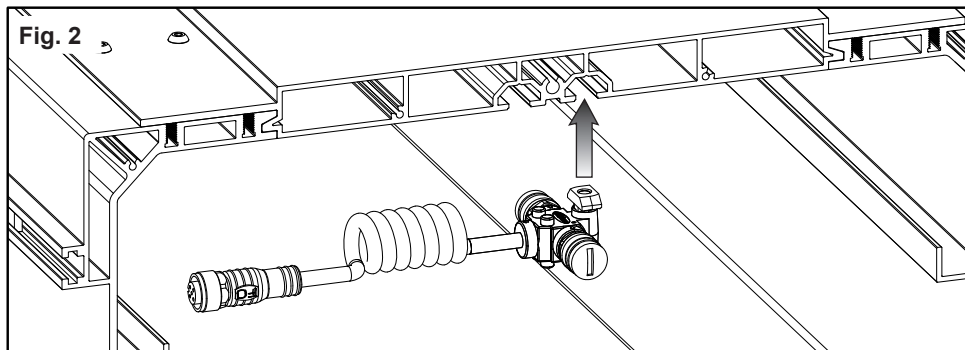

Fig. 3

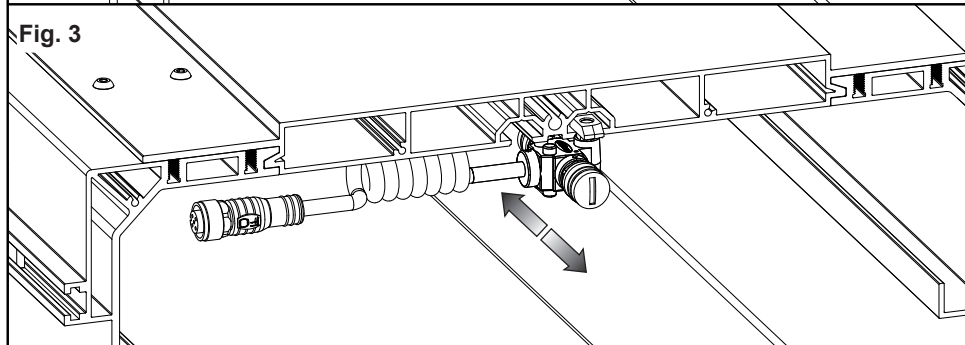

Fig. 4

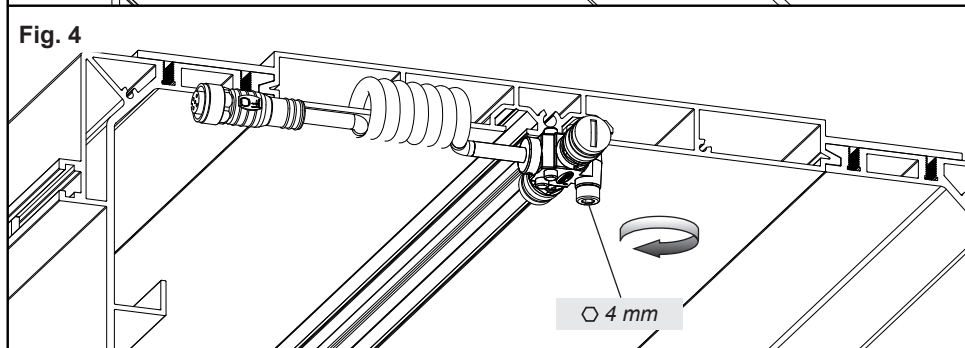

Fig. 5

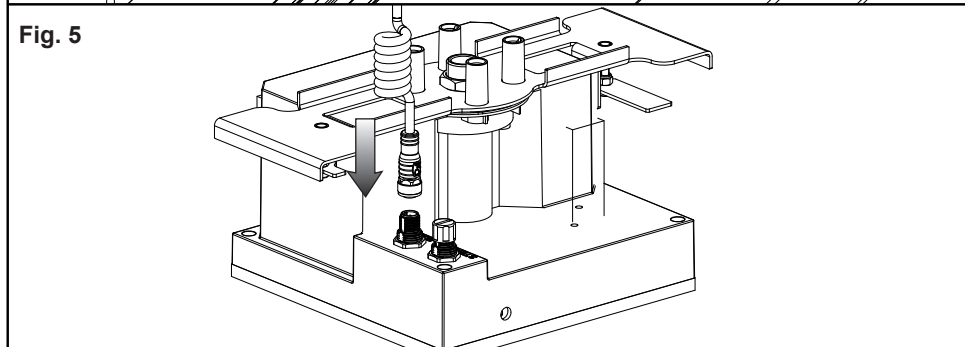



Fig. 6

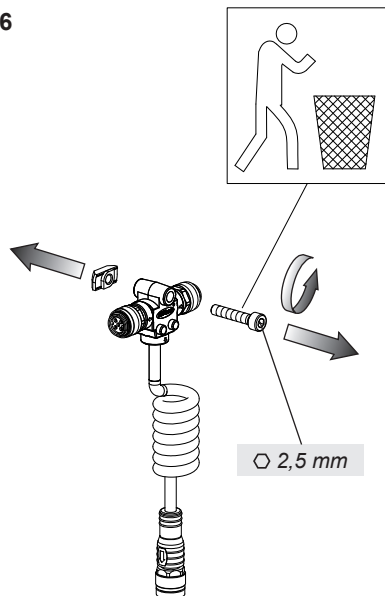

Fig. 7

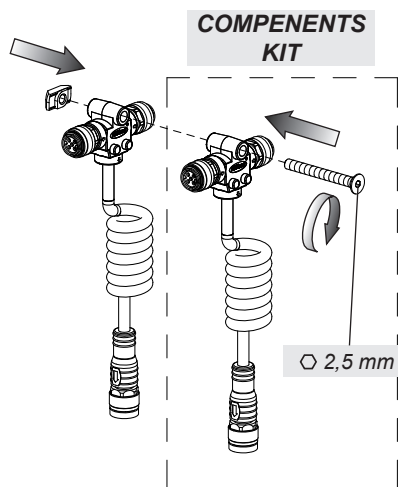



Fig. 8

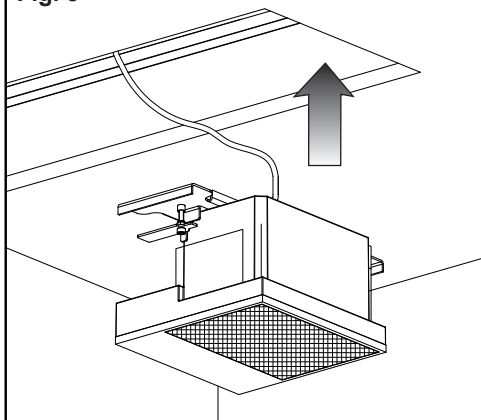

Fig. 9

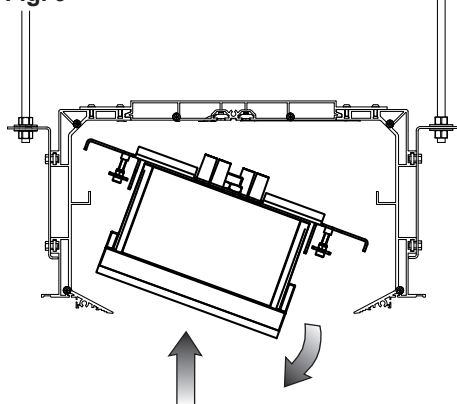

Fig. 10

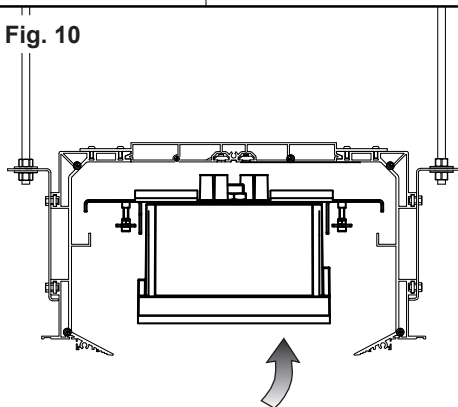

Fig. 11

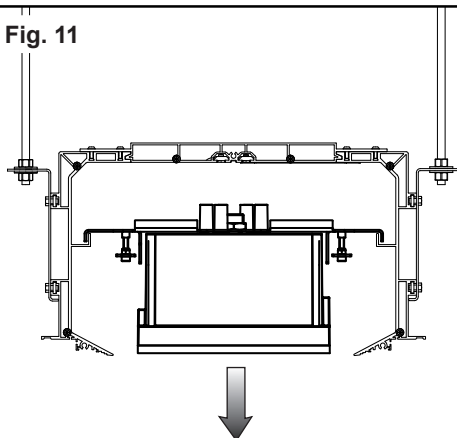

Fig. 12

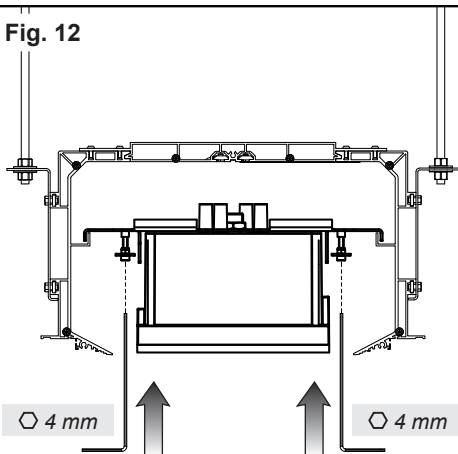
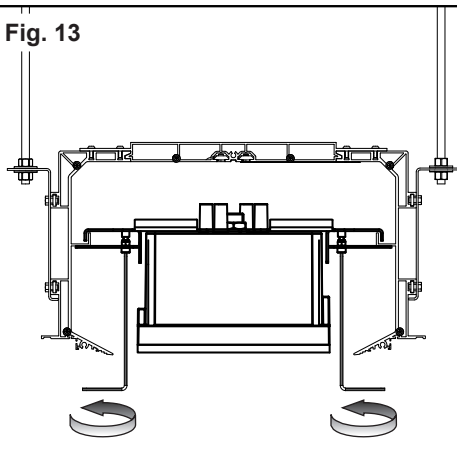

Fig. 13





MANUTENZIONE

- Nel caso sia necessario sostituire uno o più componenti, contattare un rivenditore autorizzato o visitare il sito WWW.GESSI.COM
- Affidare la manutenzione del prodotto a personale qualificato

MAINTENANCE

- Should it be necessary to replace one or more components, contact an authorized retailer or visit WWW.GESSI.COM
- Product maintenance should be made only by qualified staff

ENTRETIEN

- S'il est nécessaire de remplacer un ou plusieurs composants, contacter un centre autorisé ou visiter le site WWW.GESSI.COM
- L'entretien du produit ne doit être effectué que par du personnel qualifié

WARTUNG

- Falls das Auswechseln von einem oder mehreren Bestandteilen erforderlich wird, kontaktieren Sie bitte einen autorisierten Fachhandel oder besuchen Sie unsere Website unter WWW.GESSI.COM
- Die Instandhaltung des Produktes sollte nur qualifiziertem Personal anvertraut werden.

MANUTENCIÓN

- En el caso de que sea necesario replazar uno o más componentes, contacten con un revendedor autorizado o visiten el sitio WWW.GESSI.COM
- Encarguen sólo a personal calificado para el mantenimiento del producto

ОБСЛУЖИВАНИЕ

- В случае если будет необходимо заменить один или несколько компонентов, обратитесь к авторизованному дистрибьютору или посетите веб-сайт WWW.GESSI.COM
- Обслуживание изделия должен выполнить квалифицированный персонал.

ΣΥΝΤΗΡΗΣΗ

- Σε περίπτωση που είναι απαραίτητο να αντικαταστήσετε ένα ή περισσότερα εξαρτήματα, επικοινωνήστε με ένα εξουσιοδοτημένο κατάστημα πώλησης ή επισκεφθείτε τον ιστότοπο WWW.GESSI.COM
- Εμπιστευθείτε τη συντήρηση του προϊόντος σε διαπιστευμένο προσωπικό

保养

- 若需替换一个或者多个部件，请联系授权分销商或浏览WWW.GESSI.COM网站
- 请让合格人士负责产品保养工作

