

PROGRAMMA MISCELAZIONE BAGNO
BATH MIXING PROGRAM
PROGRAMME DU MITIGEUR POUR LA SALLE DE BAIN
BAD-MISCHUNGSPROGRAMM
PROGRAMA MEZCLADORES BAÑO
ПРОГРАММА СМЕСИТЕЛЕЙ ДЛЯ ВАННОЙ
ΑΝΑΜΙΚΤΙΚΟ ΠΡΟΓΡΑΜΜΑ ΜΠΑΝΙΟΥ
浴室混水产品

ARCHITECTURAL WELLNESS

Art. 61217

Art. 61229

GESSI 

Gessi SpA - Parco Gessi
13037 Serravalle Sesia (Vercelli) - Italy
Phone +39 0163 454111 - Facsimile +39 0163 459273

www.gessi.com - gessi@gessi.it

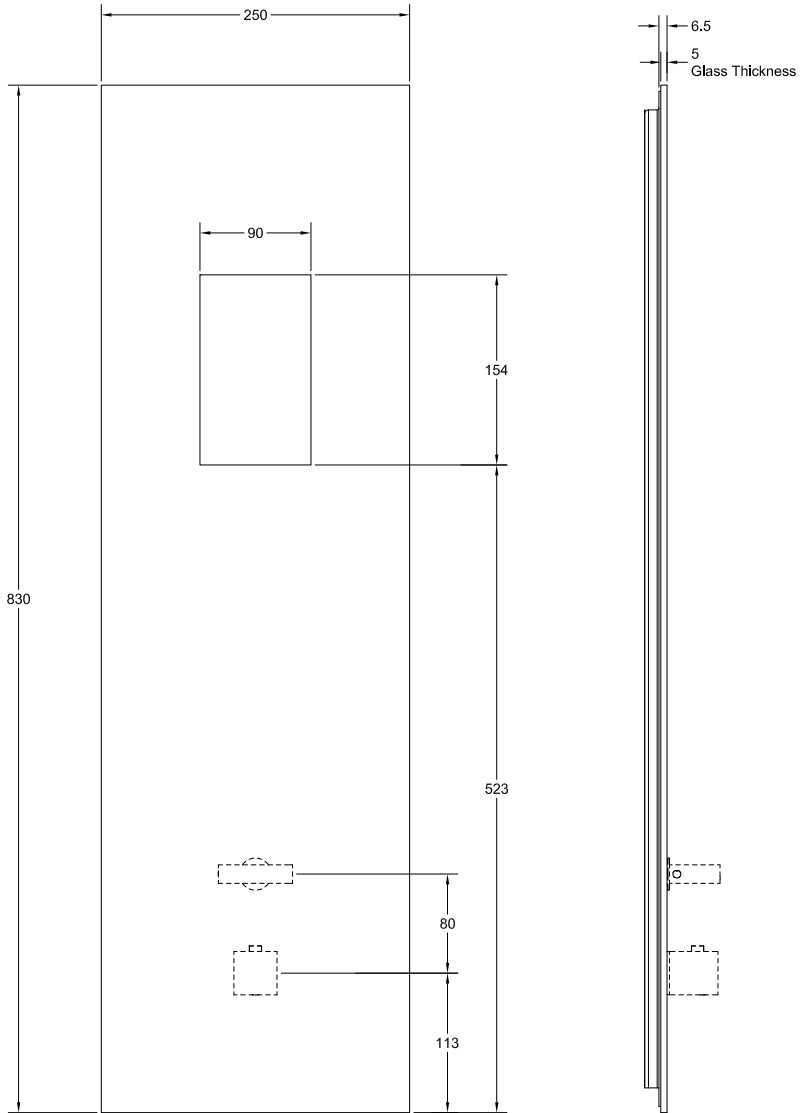



Le caratteristiche generali del sistema "Architectural Wellness" sono identificate sull'etichetta dell'elettronica presente negli articoli 61201-61203 (vedi immagine sotto).

The general features of the "Architectural Wellness" system are shown in the electronics identification plate of the items 61201 - 61203 (see picture below).

Les caractéristiques générales du système "Architectural Wellness" sont indiquées sur la plaque d'identification de l'électronique des articles 61201-61203 (voir image dessous).

Die allgemeinen Eigenschaften des Systems "Architectural Wellness" sind auf dem Etikett der Elektronik identifiziert, die sich in den Artikeln 61201-61203 befinden (siehe nachfolgende Abbildung).

Las características generales del sistema "Architectural Wellness" se indican en la placa de identificación de la electrónica de los artículos 61201 - 61203 (ver imagen a continuación).

Основные характеристики системы "Architectural Wellness" указываются в идентификационной табличке электронных компонентов изделий 61201 - 61203 (см. нижеупомянутый рисунок).

Τα γενικά χαρακτηριστικά του συστήματος "Architectural Wellness" προσδιορίζονται στην ετικέτα του ηλεκτρονικού μέρους που υπάρχει στα προϊόντα 61201-61203 (βλέπε παρακάτω εικόνα).

"Architectural Wellness" 系统的一般特征可以从货号61201-61203产品上电子器件的标签上找到（参见下图）

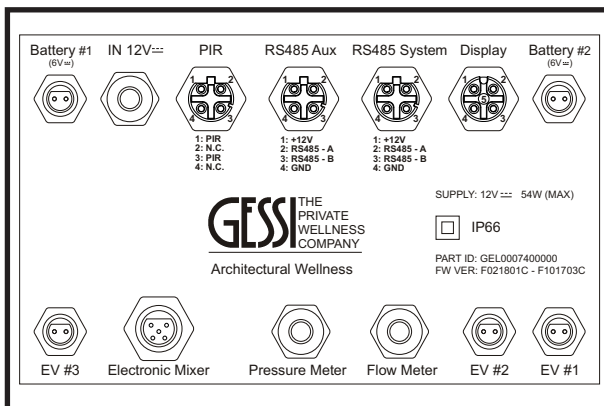

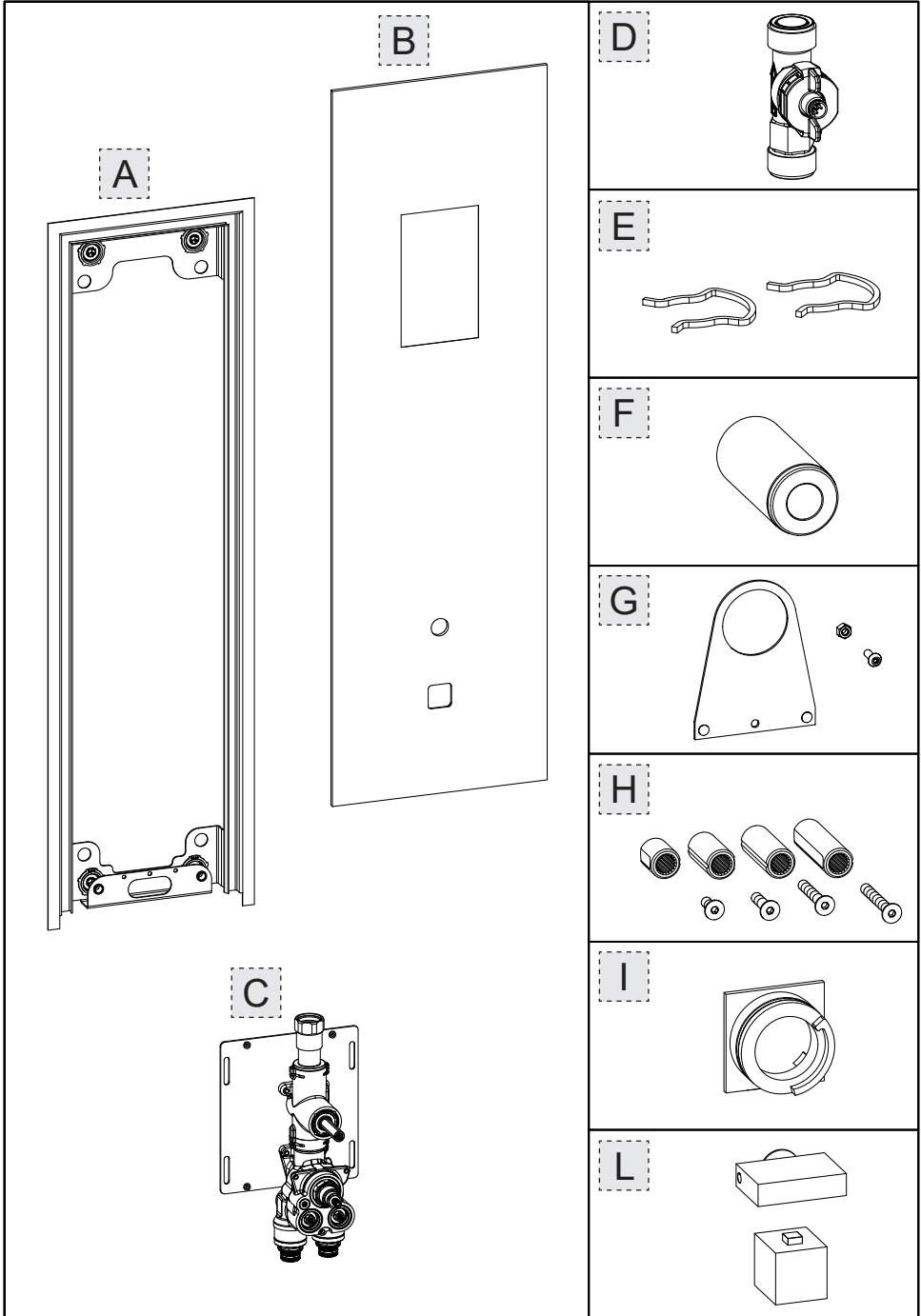



Contenuto della confezione:

- A - Piastra di fissaggio
- B - Touch screen
- C - Corpo miscelatore
- D - Flussimetro
- E - Anello elastico
- F - Supporto di centraggio
- G - Staffa di centraggio
- H - Kit prolunga comando termostatico
- I - Anello indicatore
- L - Maniglie di comando

Package content:

- A - Fastening plate
- B - Touch screen
- C - Mixer body
- D - Flow-meter
- E - Elastic ring
- F - Centring support
- G - Centring bracket
- H - Thermostatic control extension kit
- I - Dial ring
- L - Control handles

Contenu de l'emballage:

- A - Plaque de fixation
- B - Touch screen
- C - Corps mélangeur
- D - Débitmètre
- E - Anneau élastique
- F - Support de centrage
- G - Étrier de centrage
- H - Kit d'extension commande thermostatique
- I - Bague indicateur
- L - Poignée de commande

Inhalt der Verpackung:

- A - Befestigungsplatte
- B - Touch screen
- C - Mischerkörper
- D - Durchflussmesser
- E - Spannring
- F - Zentrierungsgehäuse
- G - Zentrierungsbügel
- H - Verlängerungsbausatz für dir thermostatische Steuerung
- I - Anzeigering
- L - Steuergriffe

Contenido de la caja:

- A - Placa de fijación
- B - Touch screen
- C - Cuerpo del mezclador
- D - Fluxómetro
- E - Aro elástico
- F - Soporte de centrado
- G - Brida de centrado
- H - Juego de extensión del mando termostático
- I - Anillo indicador
- L - Manetas de mando

Содержимое упаковки:

- A - Крепежная пластина
- B - Сенсорный экран
- C - Корпус смесителя
- D - Расходомер
- E - Зажимное кольцо
- F - Центрирующий суппорт
- G - Центрирующая скоба
- H - Комплект удлинителя термостатического управления
- I - Кольцо-указатель
- L - Ручки управления

Περιεχόμενο συσκευασίας:

- A - Πλάκα στερέωσης
- B - Θθόνη αφής
- C - Σώμα μπαταρίας αναμίκτη
- D - Ροόμετρο
- E - Ελαστικός δακτύλιος
- F - Βάση κεντραρίσματος
- G - Σφιγκτήρας κεντραρίσματος
- H - Kit προέκτασης θερμοστατικού χειριστηρίου
- I - Δακτύλιος ένδειξης
- L - Λαβές εντολής

包装内含:

- A - 固定面板
- B - 触摸屏
- C - 混水器机体
- D - 流量计
- E - 弹性环
- F - 对中工装
- G - 对中架
- H - 恒温手柄延伸套件
- I - 指示环
- L - 控制手柄



Fig. 1

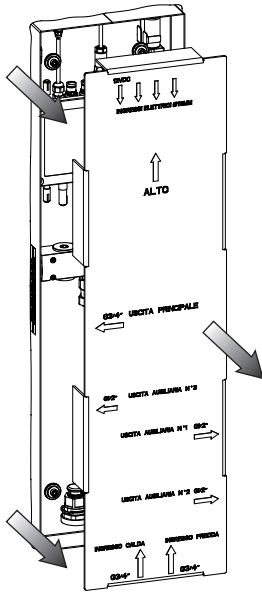

Fig. 2

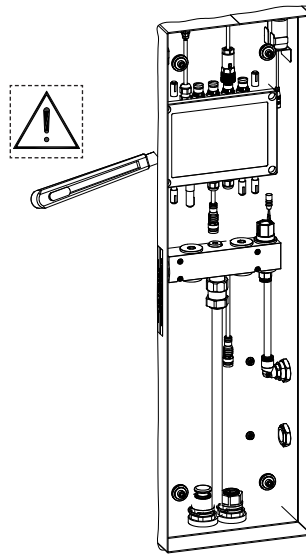

Fig. 3

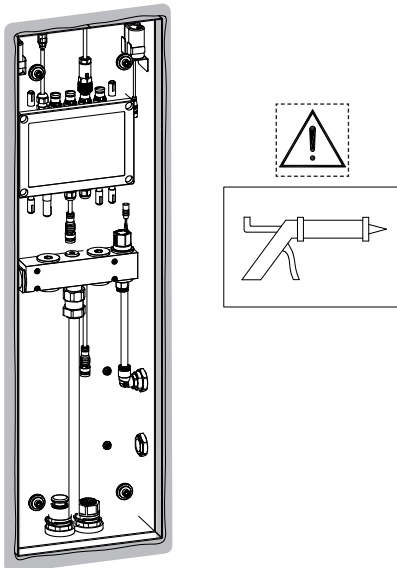

Fig. 4

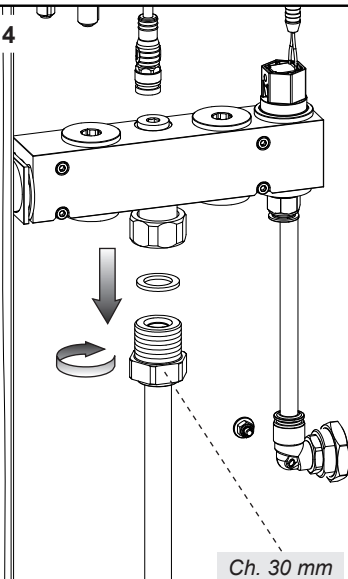



Fig. 5

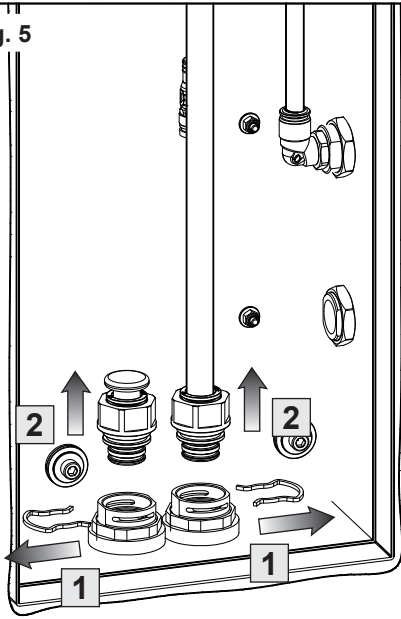

Fig. 6

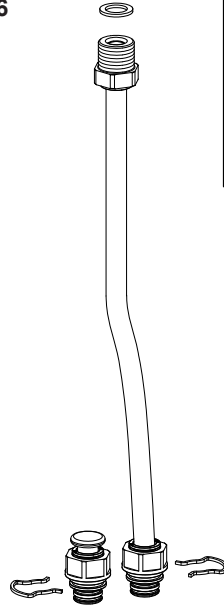

Fig. 7

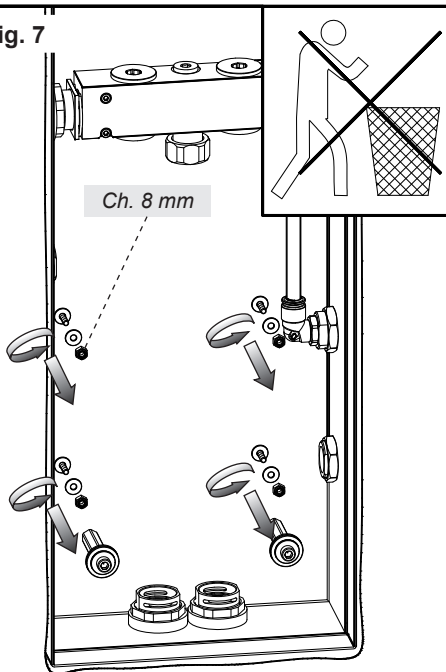

Fig. 8

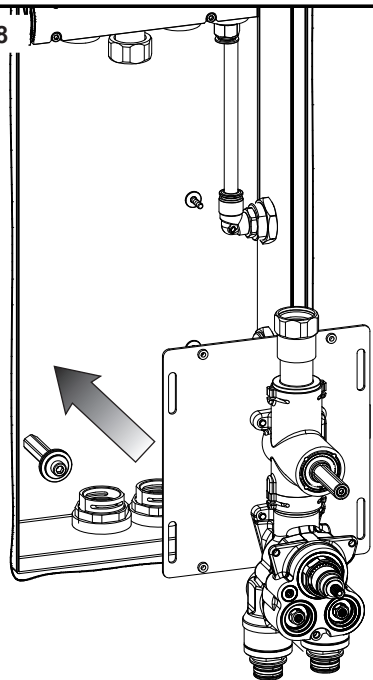



Fig. 9

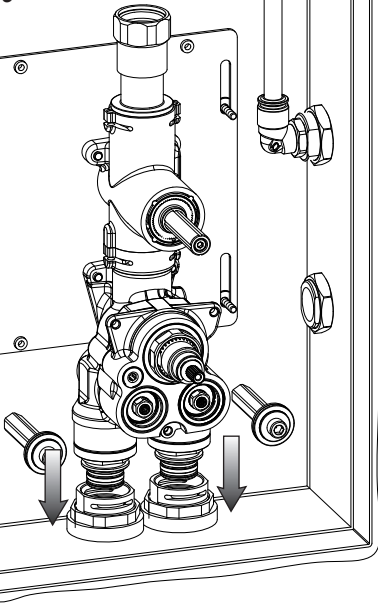

Fig. 10

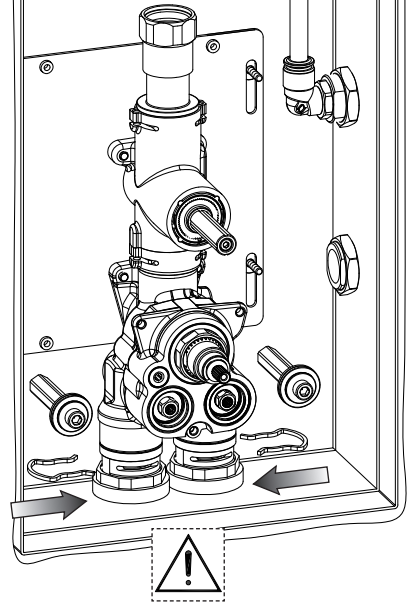

Fig. 11

Ch. 8 mm

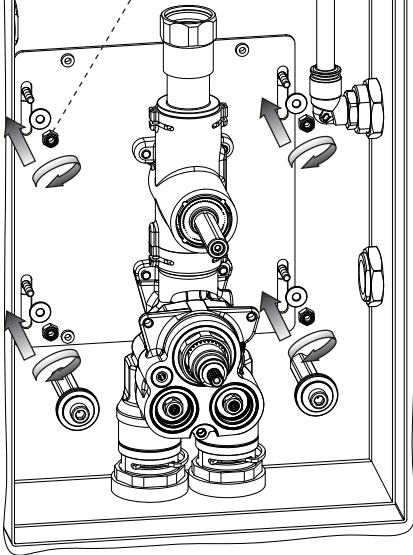

Fig. 12

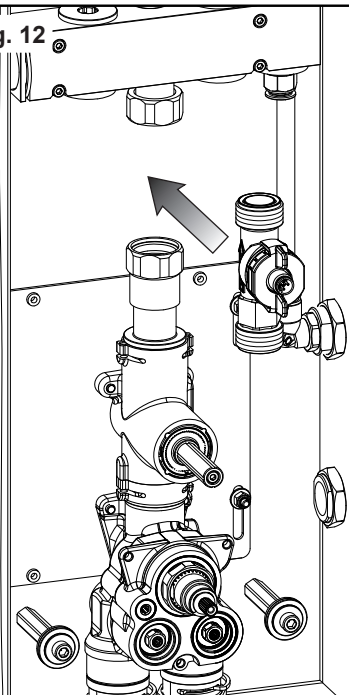



Fig. 13

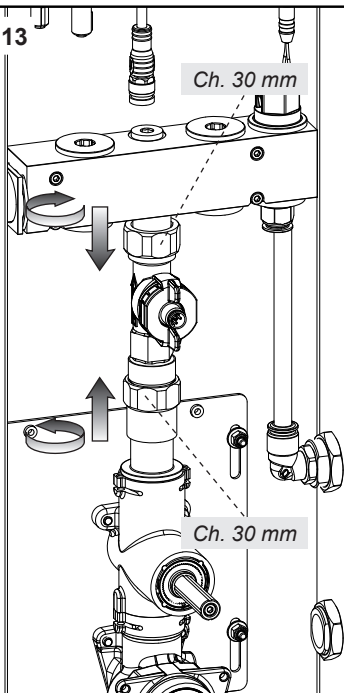

Fig. 14

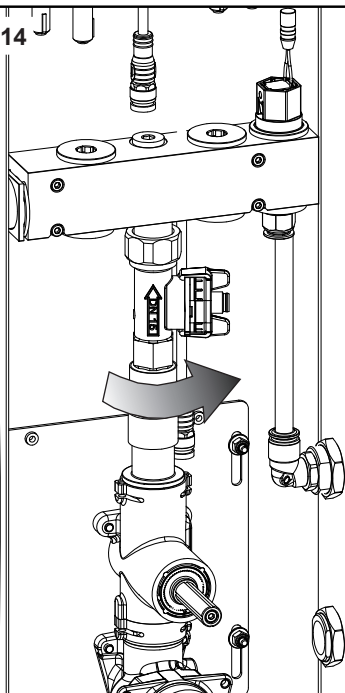

Fig. 15

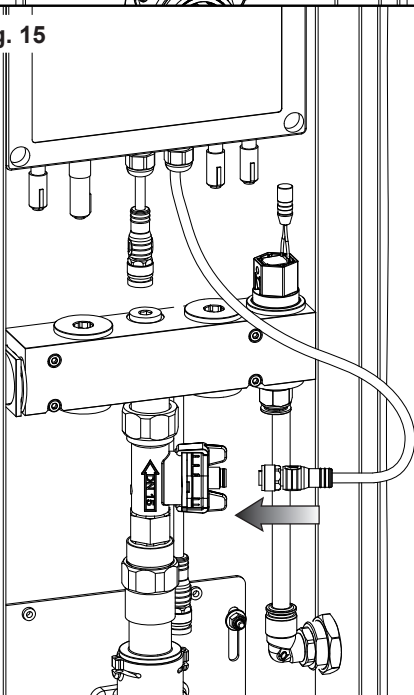
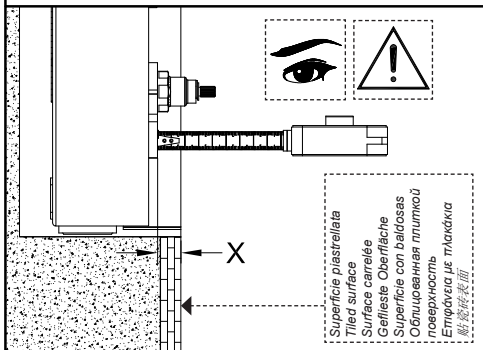
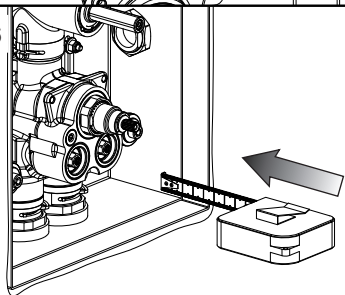
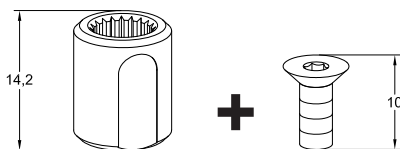

Fig. 16





0mm ÷ 3mm



3mm ÷ 10mm

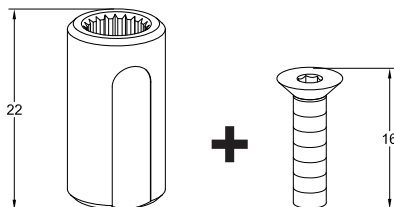

10mm ÷ 17mm

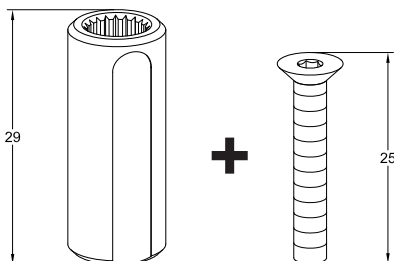

17mm ÷ 25mm

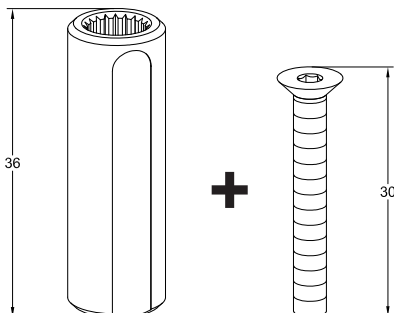



Fig. 17

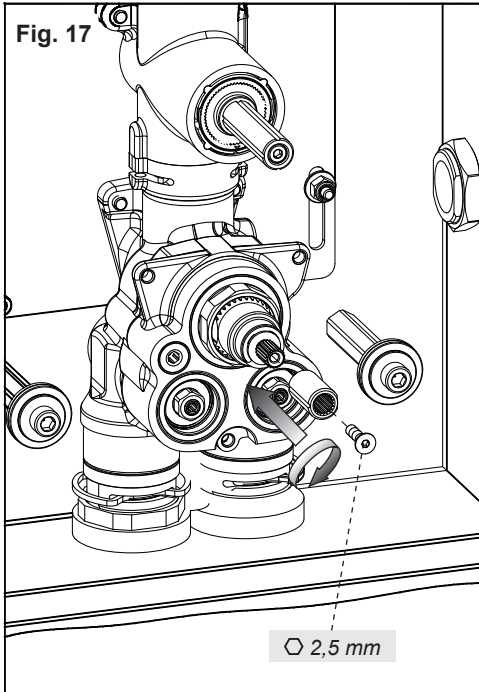

Fig. 18

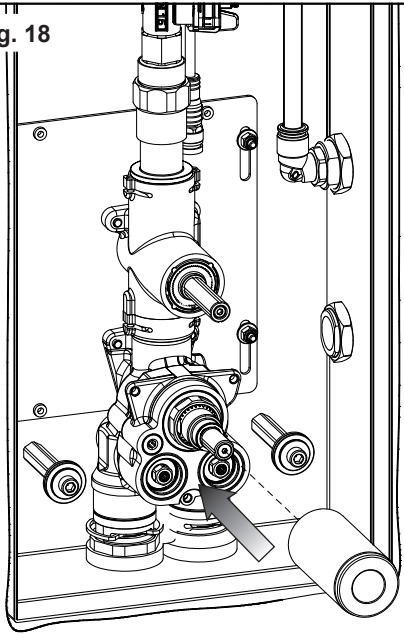

Fig. 19

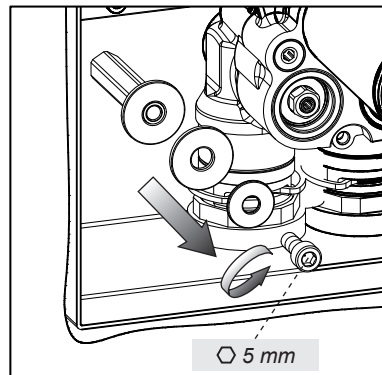
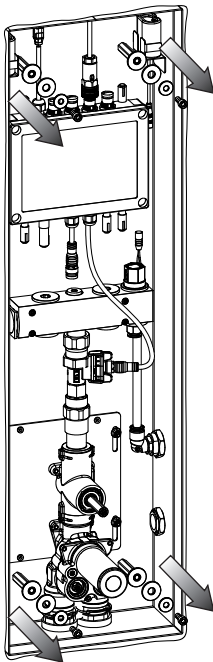



Fig. 20

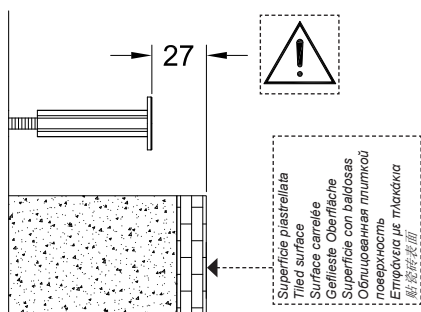
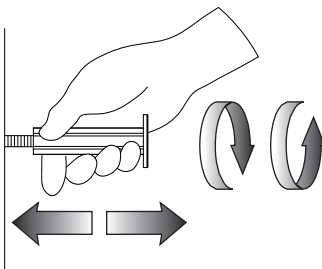
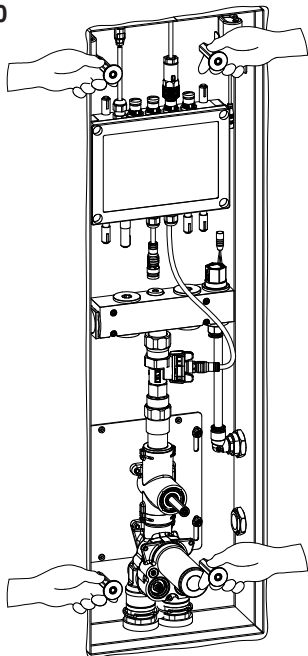

Fig. 21

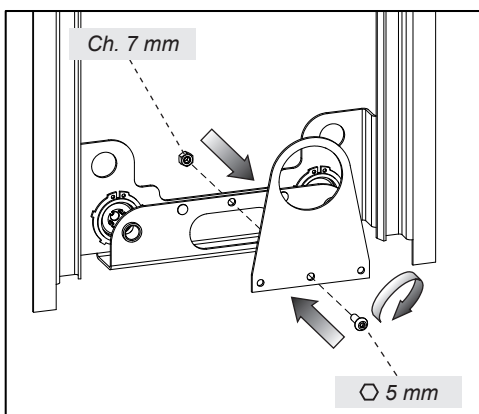
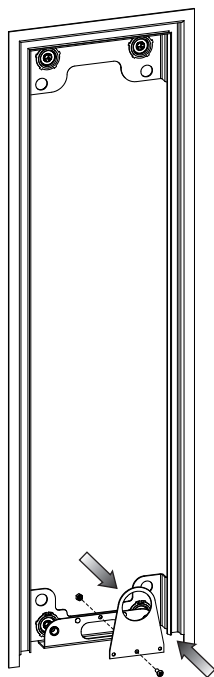



Fig. 22

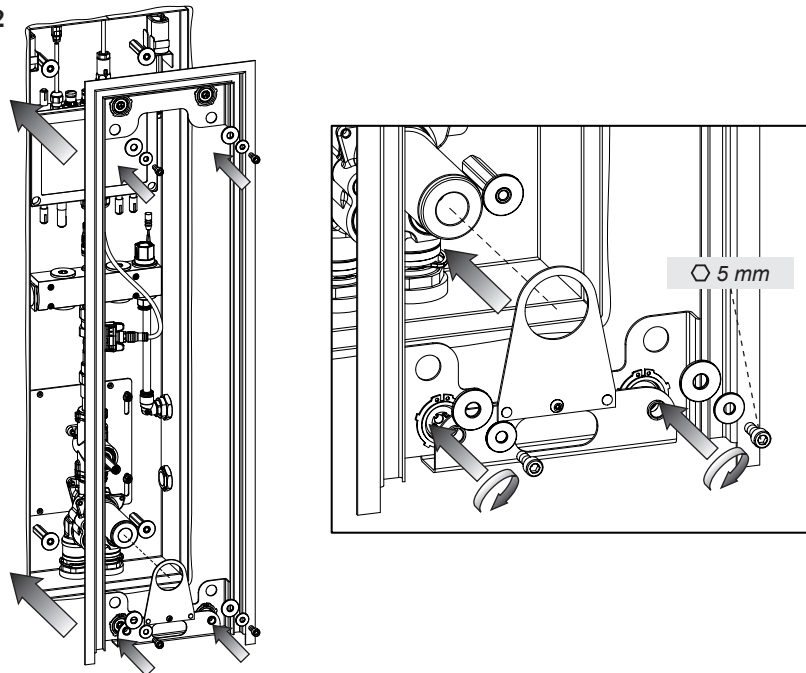

Fig. 23

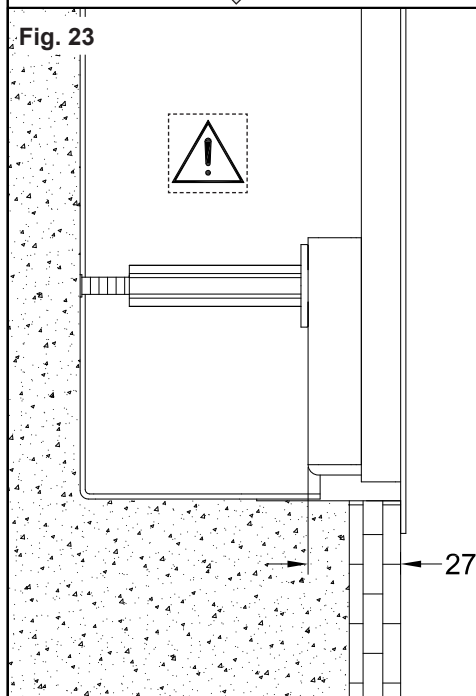

Fig. 24

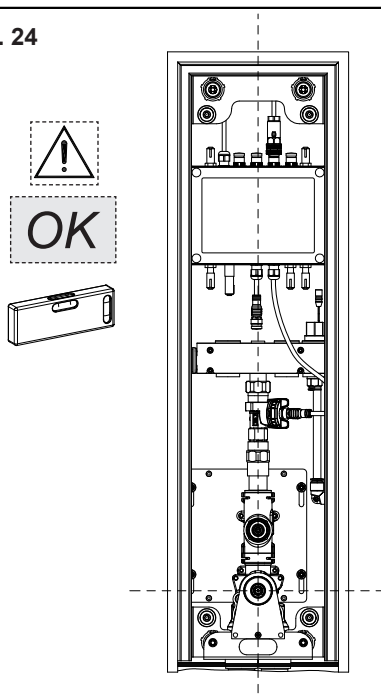



Fig. 25

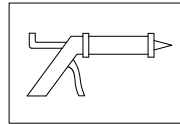
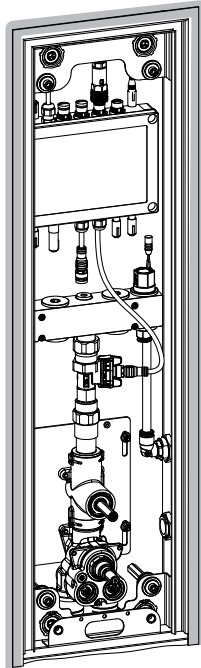

Fig. 26

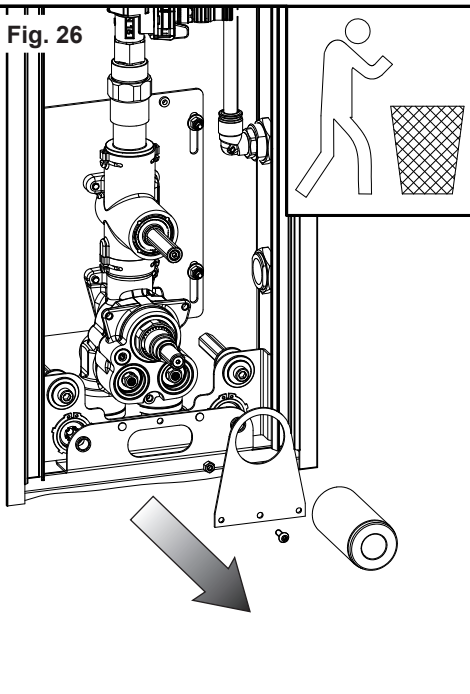

Fig. 27

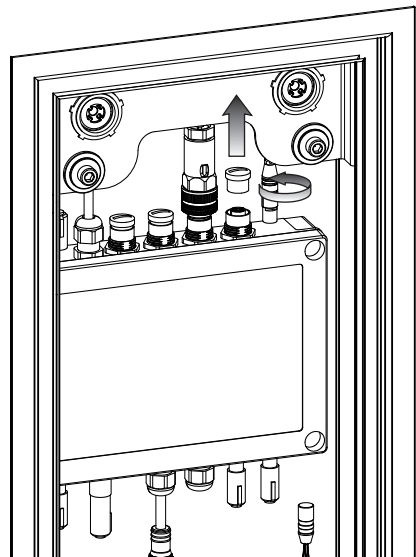



Fig. 28

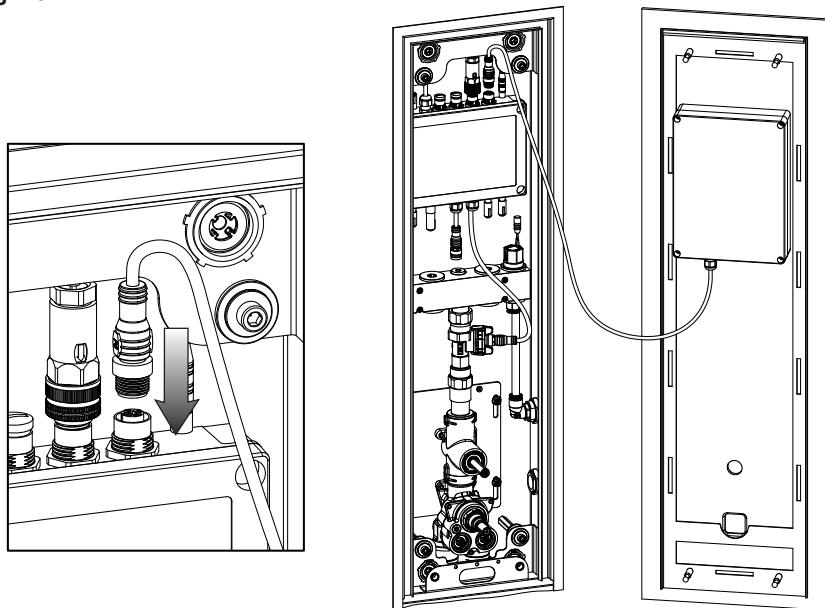

Fig. 29

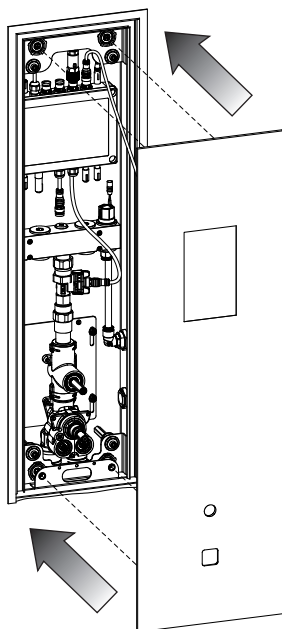

Fig. 30

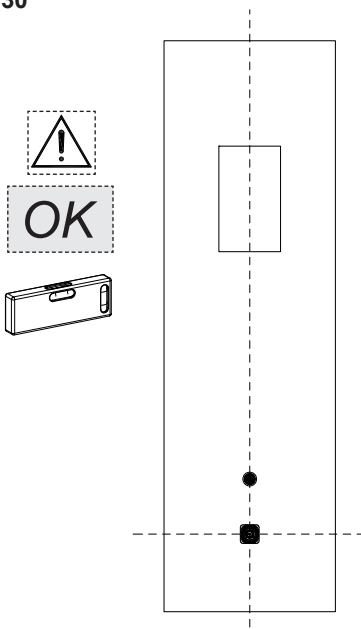



Fig. 31

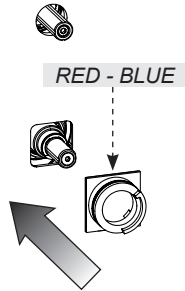

Fig. 32

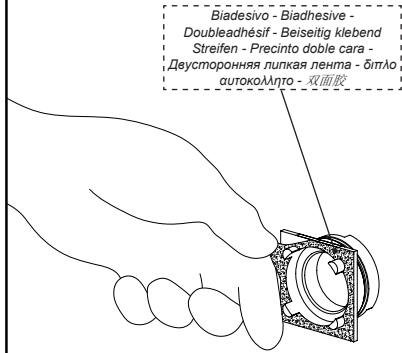

Fig. 33

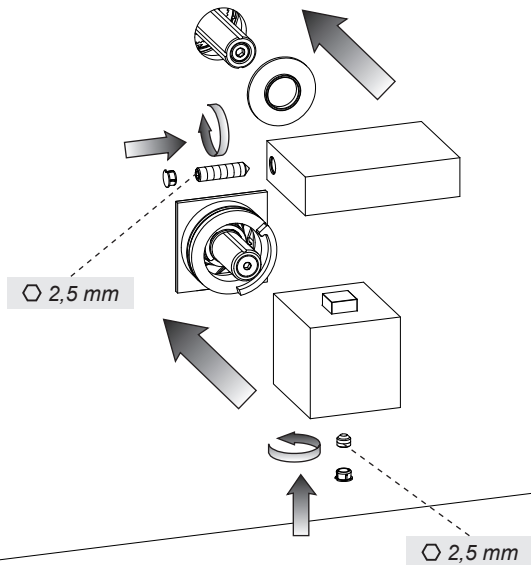
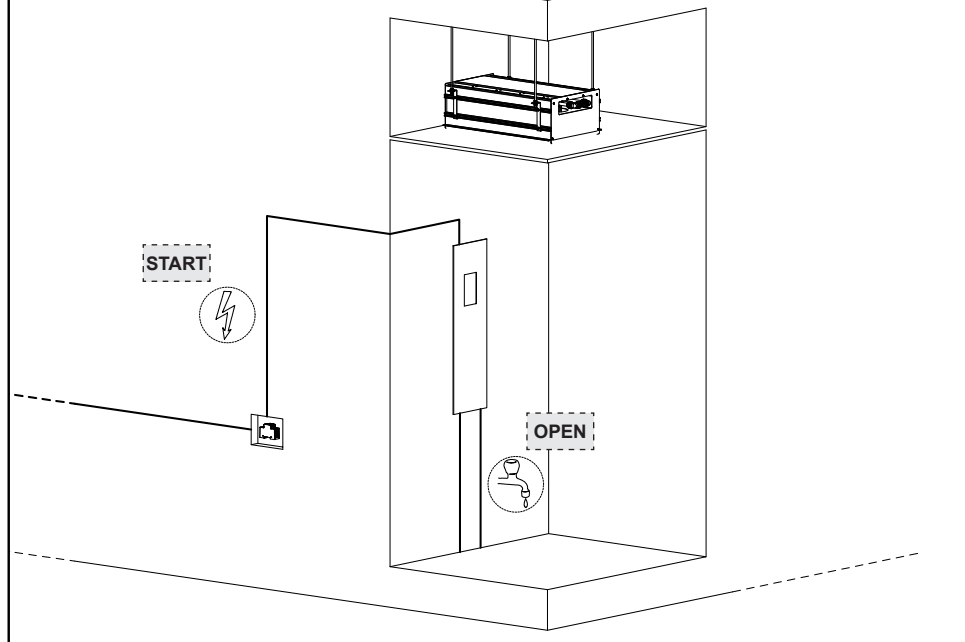
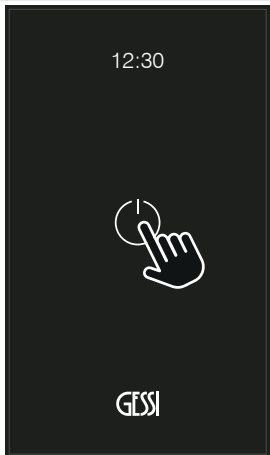



Fig. 34





PRIMO UTILIZZO

La prima volta che si avvia il sistema operativo è necessario regolare le seguenti funzioni:

- SETTING GENERALE
- LAYOUT MODULI

Per la regolazione di ogni parametro vedere il capitolo dedicato.

FIRST USE

The first time you start the operational system, you need to adjust the following functions:

- GENERAL SETTINGS
- MODULES LAYOUT

See the dedicated chapter in order to adjust each parameter.

PREMIERE UTILISATION

Lors de la première utilisation du système opérationnel il est nécessaire de régler les fonctions suivantes:

- SETTING GENERAL
- LAYOUT MODULES

Pour le réglage de chaque paramètre, voir le chapitre adéquat.

ERSTBENUTZUNG

Wenn man das Betriebssystem zum ersten Mal startet, muss man die folgenden Funktionen einstellen:

- ALLGEMEINES SETTING
- LAYOUT DER MODULE

Informationen zur Einstellung der einzelnen Parameter finden Sie im entsprechenden Kapitel.

PRIMERA UTILIZACIÓN

Quando se pone en marcha el sistema operativo por primera vez, es necesario regular las siguientes funciones:

- SETTING GENERAL
- LAYOUT MÓDULOS

Para la regulación de cada parámetro, vean el capítulo correspondiente.

ПЕРВОЕ ИСПОЛЬЗОВАНИЕ

При первом запуске операционной системы необходимо настроить следующие функции:

- ОБЩИЕ НАСТРОЙКИ
- КОМПОНОВКА МОДУЛЕЙ

Для настройки каждого параметра см. соответствующую главу.

ΠΡΩΤΗ ΧΡΗΣΗ

Η πρώτη φορά που τίθεται σε εκκίνηση το λειτουργικό σύστημα είναι απαραίτητο να ρυθμίσετε τις ακόλουθες λειτουργίες:

- ΓΕΝΙΚΗ ΡΥΘΜΙΣΗ
- ΔΙΑΤΑΞΗ ΣΤΟΙΧΕΙΩΝ

Για την ρύθμιση της κάθε παραμέτρου δείτε το σχετικό κεφάλαιο.

第一次使用

第一次启动操作系统时需要调节下列功能:

- 一般设置
- 模块布局

就每个参数调节请参见专门章节。

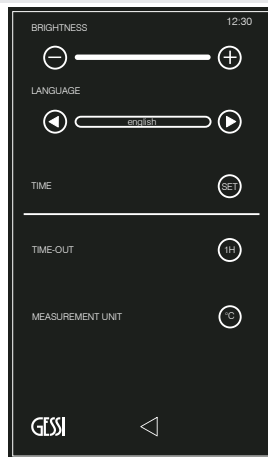
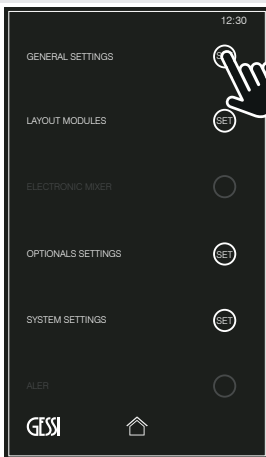
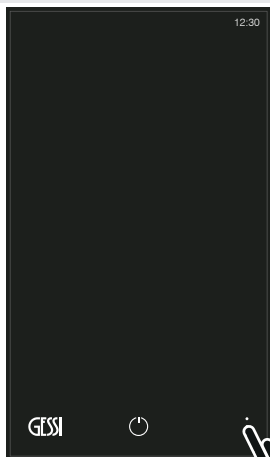

SETTING GENERALE

- Luminosità
- Lingua
- Ora
- Auto-spegnimento
- Unità di misura

GENERAL SETTINGS

- Brightness
- Language
- Time
- Time-out
- Measurement unit

SETTING GENERAL

- Luminosité
- Langue
- Heure
- Arrêt automatique
- Unité de mesure

ALLGEMEINES SETTING

- Helligkeit
- Sprache
- Uhrzeit
- Selbstausschaltung
- Maßeinheit

SETTING GENERAL

- Luminosidad
- Idioma
- Hora
- Auto-apagado
- Unidad de medición

ОБЩИЕ НАСТРОЙКИ

- Яркость
- Язык
- Время
- Автоматическое выключение
- Единицы измерения

ΓΕΝΙΚΗ ΡΥΘΜΙΣΗ

- Φωτεινότητα
- Γλώσσα
- Ωρα
- Αυτόματο σβήσιμο
- Μονάδα μέτρησης

一般設置

- 亮度
- 语言
- 时间
- 自动关闭
- 单位

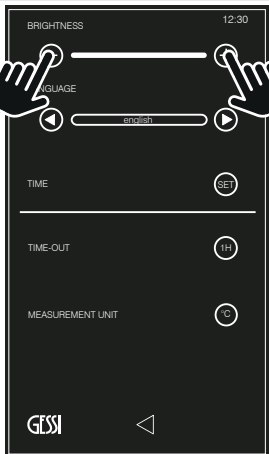

LUMINOSITA' - BRIGHTNESS - LUMINOSITÉ - HELLIGKEIT - LUMINOSIDAD - ЯРКОСТЬ - ΦΩΤΕΙΝΟΤΗΤΑ - 亮度



- Consente di aumentare o diminuire la luminosità del touch screen
- Allows increasing or decreasing touch screen brightness
- Permet d'augmenter ou de réduire la luminosité du touch screen
- Ermöglicht das Erhöhen oder Verringern der Helligkeit vom Touchscreen
- Permite aumentar o disminuir la luminosidad del touch screen
- Позволяет увеличить или уменьшить яркость сенсорного экрана
- Επιτρέπει την αύξηση ή μείωση της φωτεινότητας της οθόνης αφής
- 可以增加或降低触摸屏亮度

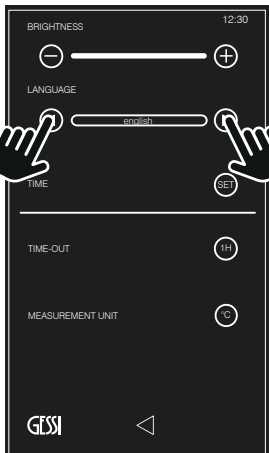

LINGUA - LANGUAGE - LANGUE - SPRACHE - IDIOMA - ЯЗЫК - ΓΛΩΣΣΑ - 语言



- Impostare la lingua desiderata
- Set the desired language
- Programmer la langue désirée
- Einstellen der gewünschten Sprache
- Elijan el idioma deseado
- Выберите язык
- Ρυθμίστε την επιθυμητή γλώσσα
- 设置所需语言

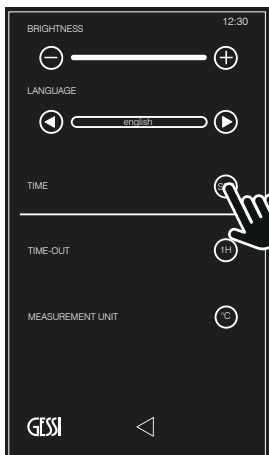

ORA - TIME - HEURE - UHRZEIT - HORA - ВРЕМЯ - ΩΡΑ - 时间



- Premere per accedere al menu (consultare la sezione dedicata)
- Press for menu access (consult the dedicated section)
- Appuyer pour accéder au menu (voir la section adéquate)
- Drücken, um auf das Menü zuzugreifen (konsultieren Sie hierzu den entsprechenden Abschnitt)
- Pulsen para tener acceso al menú (consulten la sección dedicada)
- Нажмите для доступа к меню (см. соответствующий раздел)
- Πατήστε για να έχετε πρόσβαση στο μενού (συμβουλευτείτε το σχετικό τμήμα)
- 按，以进入菜单（阅读专门的章节）

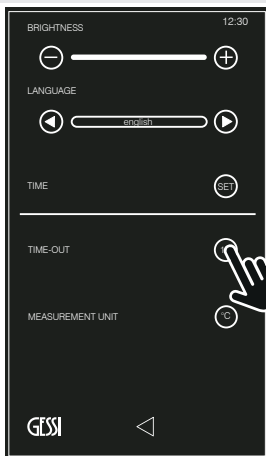

AUTO-SPEGNIMENTO - TIME OUT - ARRÊT AUTOMATIQUE - SELBSTAUSCHALTUNG - AUTO-APAGADO - АВТОМАТИЧЕСКОЕ ВЫКЛЮЧЕНИЕ - ΑΥΤΟΜΑΤΟ ΣΒΗΣΙΜΟ - 自动关闭

(1h) Dopo 1 ora - After 1 hour - Après 1 heure - Nach 1 Stunde - Después de 1 hora - Через 1 час - Μετά από 1 ώρα - 1小时后

(12h) Dopo 12 ore - After 12 hours - Après 12 heures - Nach 12 Stunden - Después de 12 horas - Через 12 часов - Μετά από 12 ώρες - 12小时后

(OFF) Disattivato - Disabled - Désactivé - Deaktiviert - Desactivado - Отключено - Απενεργοποιημένο - 关闭

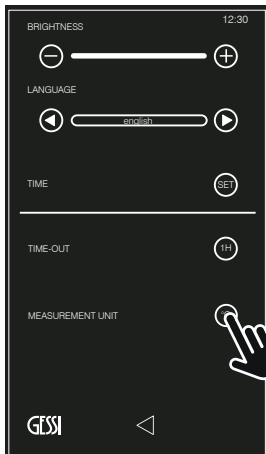

UNITA' DI MISURA - MEASUREMENT UNIT - UNITÉ DE MESURE - MASSEINHEIT - UNIDAD DE MEDICIÓN - ЕДИНИЦЫ ИЗМЕРЕНИЯ - ΜΟΝΑΔΑ ΜΕΤΡΗΣΗΣ - 單位

(°C) Temperatura dell'acqua indicata in gradi Celsius - Water temperature indicated in Celsius degrees - Température de l'eau indiquée en degrés Celsius - Wassertemperatur, angegeben in Grad Celsius - Temperatura del agua indicada en grados Celsius - Температура воды в градусах Цельсия - Θερμοκρασία του νερού αναφερόμενη σε βαθμούς Κελσίου - 以摄氏温度表示的水温

(°F) Temperatura dell'acqua indicata in gradi Fahrenheit - Water temperature indicated in Fahrenheit degrees - Température de l'eau indiquée en degrés Fahrenheit - Wassertemperatur, angegeben in Grad Fahrenheit - Temperatura del agua indicada en grados Fahrenheit - Температура воды в градусах Фаренгейта - Θερμοκρασία του νερού αναφερόμενη σε βαθμούς Κελσίου - 以华氏温度表示的水温

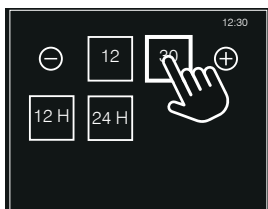
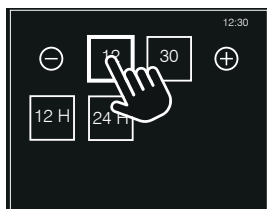
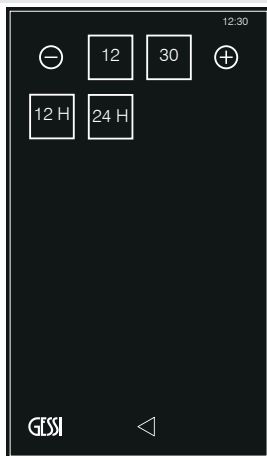

REGOLAZIONE ORA E MINUTI
HOURLY AND MINUTES ADJUSTMENT
RÉGLAGE HEURE ET MINUTES
EINSTELLUNG VON STUNDE UND MINUTEN
REGULACIÓN HORA Y MINUTOS
НАСТΡΟΪΚΑ ΧΑΡΑΚΤΗΡΙΣΤΙΚΩΝ
ΡΥΘΜΙΣΗ ΩΡΑΣ ΚΑΙ ΛΕΠΤΩΝ
时和分调节

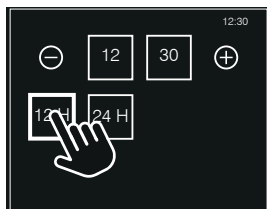
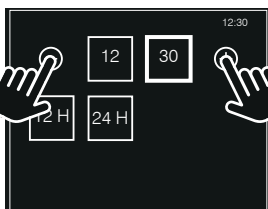
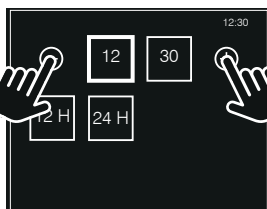

FORMATO ORA
TIME FORMAT
FORMAT HEURE
FORMAT DER UHRZEIT
FORMATO HORA
ΦΟΡΜΑΤ ΒΡΕΜΕΝΗ
ΜΟΡΦΗ ΩΡΑΣ
时间显示格式

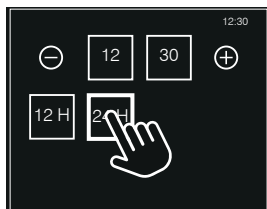

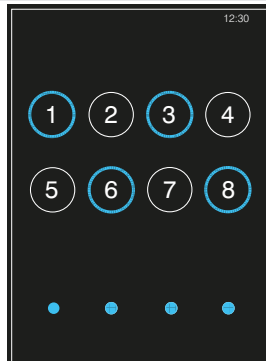
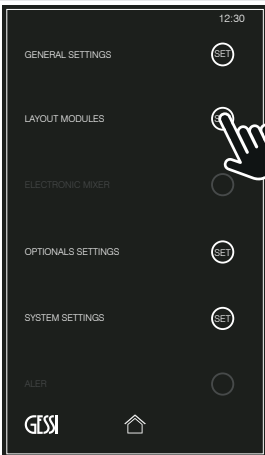
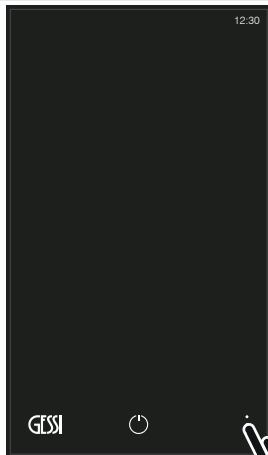

PASSWORD: 1638

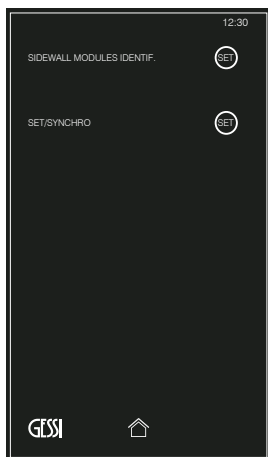

LAYOUT MODULI

- Identificazione moduli a parete
- Set/Sincro

MODULES LAYOUT

- Sidewall modules identification
- Set/Synchro

LAYOUT MODULES

- Identification modules à paroi
- Set/Synchro

LAYOUT DER MODULE

- Identifikation der Wandmodule
- Set/Synchro

LAYOUT MÓDULOS

- Identificación módulos de pared
- Set/Sincro

ΚΟΜΠΟΝΟΒΚΑ ΜΟΔΥΛΕΪ

- Идентификация настенных модулей
- Настройка/Синхронизация

ΔΙΑΤΑΞΗ ΣΤΟΙΧΕΙΩΝ

- Προσδιορισμός επιτοίχιων στοιχείων
- Set/Synchro

模块布局

- 墙装式模块识别
- Set/Synchro



IDENTIFICAZIONE MODULI A PARETE - SIDEWALL MODULES IDENTIFICATION - IDENTIFICATION OF WALL MODULES - IDENTIFIKATION DER WANDMODULE - IDENTIFICACIÓN MÓDULOS DE PARED - ИДЕНТИФИКАЦИЯ НАСТЕННЫХ МОДУЛЕЙ - ΠΡΟΣΔΙΟΡΙΣΜΟΣ ΕΠΙΤΟΙΧΙΩΝ ΣΤΟΙΧΕΪΩΝ - 墙装式模块识别



- Premere per accedere al menu (consultare la sezione dedicata)
- Press for menu access (consult the dedicated section)
- Appuyer pour accéder au menu (voir la section adéquate)
- Drücken, um auf das Menü zuzugreifen (konsultieren Sie hierzu den entsprechenden Abschnitt)
- Pulsen para tener acceso al menú (consulten la sección dedicada)
- Нажмите для доступа к меню (см. соответствующий раздел)
- Πατήστε για να έχετε πρόσβαση στο μενού (συμβουλευτείτε το σχετικό τμήμα)
- 按，以进入菜单（阅读专门的章节）



SET/SINCRO - SET/SYNCHRO - SET/SYNCHRO - SET/SYNCHRO - SET/SINCRO - НАСТΡΟΪΚΑ/ΣΙΝΧΡΟΝΙΖΑΪΑ - SET/SYNCHRO - SET/SYNCHRO



- Premere per accedere al menu (consultare la sezione dedicata)
- Press for menu access (consult the dedicated section)
- Appuyer pour accéder au menu (voir la section adéquate)
- Drücken, um auf das Menü zuzugreifen (konsultieren Sie hierzu den entsprechenden Abschnitt)
- Pulsen para tener acceso al menú (consulten la sección dedicada)
- Нажмите для доступа к меню (см. соответствующий раздел)
- Πατήστε για να έχετε πρόσβαση στο μενού (συμβουλευτείτε το σχετικό τμήμα)
- 按，以进入菜单（阅读专门的章节）

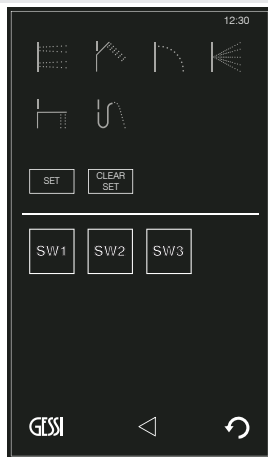

- Associare i moduli a parete (se installati) con l'icona di riferimento
- ATTENZIONE: la priorità "SW" è determinata dall'impianto**
- Associate the wall modules (if installed) with the reference icon
- ATTENTION: "SW" priority is established by the system**
- Associer les modules à paroi (si installés) à l'icône de référence
- ATTENTION : la priorité "SW" est définie par le dispositif**
- Ordnen Sie die Wandmodule (falls installiert) dem Referenzsymbol zu
- ACHTUNG: Die Priorität "SW" wird von der Anlage festgelegt**
- Asocien los módulos de pared (se instalados) con el icono de referencia
- CUIDADO: la prioridad "SW" está determinada por el sistema**
- Привяжите настенные модули (если они установлены) к соответствующей иконке.
- ВНИМАНИЕ: приоритет "SW" определяется системой**
- Συσχετισμός των επιτοίχιων στοιχείων (εάν είναι εγκαταστημένα) με την εικόνα αναφοράς
- ΠΡΟΣΟΧΗ: η προτεραιότητα "SW" καθορίζεται από την μονάδα**
- 将 (已安装) 墙装式模块与相关图标关联起来
- 注意: "SW" 顺序取决于设备**

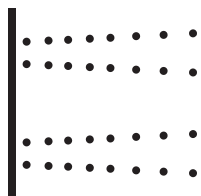

Soffioncino laterale
 Small lateral shower head
 Pomme douche laterale petite
 Seitlicher brausekopf
 Pomo de ducha lateral
 Боковая душевая лейка
 Πλευρικός φιοσητράς
 测向小喷淋器

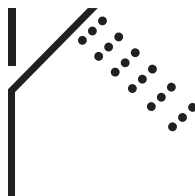

Doccetta
 Handshower
 Douchette
 Handbrause
 Ducha-téléfono
 Душ
 Ντουςάκι
 手持花洒



Cascata a parete
 Wall-mounted cascade
 Cascade à paroi
 An der Wand installierter
 Wasserfall
 Cascada de pared
 Настенный каскад
 Επιτοίχιος καταρράκτης
 墙式瀑布

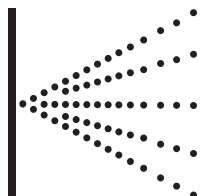

Nebulizzatore
 Atomizer
 Nébuliseur
 Zerstäuber
 Nebulizador
 Распылитель
 Καταιονιστήρας
 喷雾器

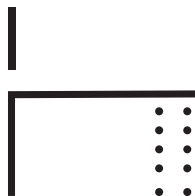

Bocca di erogazione
 Supply spout
 Bouche de débit
 Wasserauslauf
 Caño de erogación
 Излив
 Στόμιο παροχής
 出水喷嘴

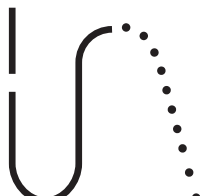

Water Tube Kneipp

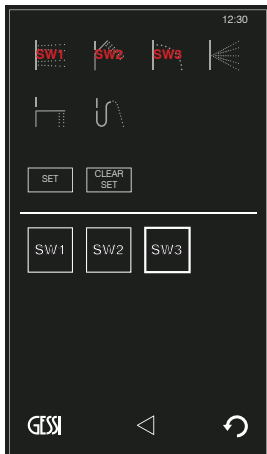
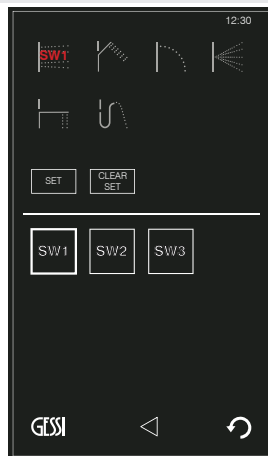
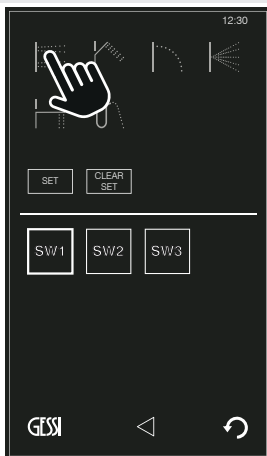
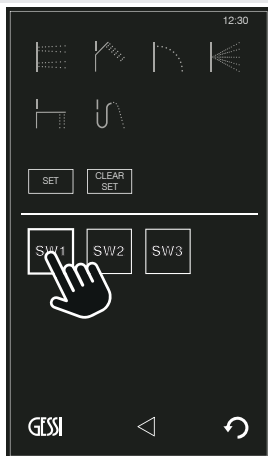

ATTENZIONE: se non si effettua l'identificazione dei moduli a parete questi non compariranno nella schermata SET/ SINCRO

ATTENTION: if identification of the wall modules is not carried out, they won't appear on the SET/SYNCHRO screen

ATTENTION: si vous n'effectuez pas l'identification des modules à paroi, ils n'apparaissent pas sur l'écran SET/ SYNCHRO

ACHTUNG: Wenn man die Identifizierung der Wandmodule nicht durchführt, erscheinen diese auch nicht im Bildschirminhalt von SET/SYNCHRO

CUIDADO: si no se efectúa la identificación de los módulos de pared, éstos no comparecerán en la pantalla SET/ SINCRO

ВНИМАНИЕ: если вы не идентифицируете настенные модули, они не появятся на экране НАСТРОЕК/ СИНХРОНИЗАЦИИ

ΠΡΟΣΟΧΗ: εάν δεν εκτελεστεί ο προσδιορισμός των επιτοιχιων στοιχειων αυτά δεν θα εμφανιστούν στην οθόνη SET/ SYNCRO

注意: 如果不执行墙装式模块识别, 这些将不会在SET/SYNCHRO页面中出现

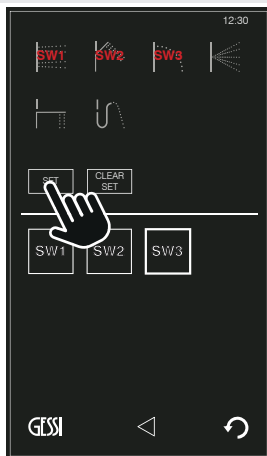

SET

- Premere per confermare e salvare la selezione
- Press to confirm and save the selection
- Appuyer pour confirmer et sauver le choix
- Drücken, um die Wahl zu bestätigen und zu sichern
- Pulsen para confirmar y guardar la selección
- Нажмите, чтобы подтвердить и сохранить выбор
- Πατήστε για να επιβεβαιώσετε και να αποθηκεύσετε την επιλογή
- 按，以确认和保存所做选择

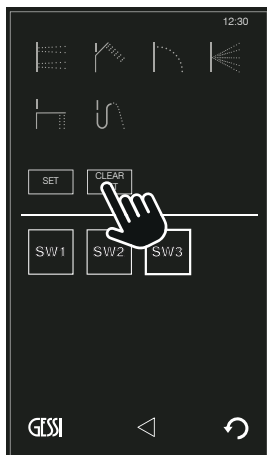

CLEAR SET

- Premere per cancellare la selezione
- Press to delete the selection
- Appuyer pour effacer le choix
- Drücken, um die Wahl zu löschen
- Pulsen para cancelar la selección
- Нажмите, чтобы отменить выбор
- Πατήστε για να ακυρώσετε την επιλογή
- 按，以删除所做选择

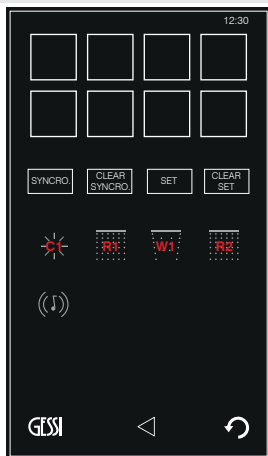

- Saranno visibili solo le icone di riferimento dei moduli installati (l'immagine a fianco è rappresentativa)
- Only the reference icons of the installed modules will be visible (the image on the side is representative)
- Seules les icônes de référence des modules installés seront visibles (l'image ci-contre n'est qu'indicative)
- Es werden nur die Referenzsymbole der installierten Module angezeigt (die seitlich dargestellte Abbildung ist rein repräsentativ)
- Estarán visibles sólo los iconos de referencia de los módulos instalados (la imagen al lado es representativa)
- Будут видны только иконки установленных модулей (изображение рядом является репрезентативным)
- Θα είναι ορατές μόνο οι εικόνες αναφοράς των εγκαταστημένων στοιχείων (η εικόνα στο πλάι είναι εκπροσωπευτική)
- 显示的只是已经安装模块对应的图标 (左面图片只是示意作用)

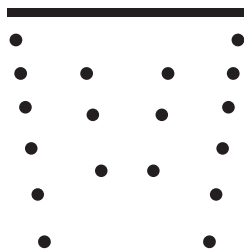

Modulo cascata
 Cascade module
 Module cascade
 Modul Wasserfall
 Módulo cascada
 Модуль водопад
 Στοιχείο καταρράκτη
 瀑布模块

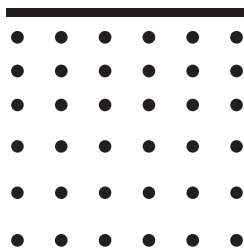

Modulo pioggia
 Rain module
 Module pluie
 Modul Berieselung
 Módulo lluvia
 Модуль дождь
 Στοιχείο βροχής
 雨淋模块

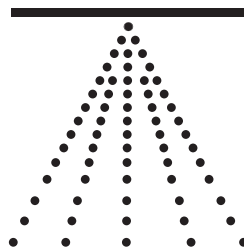

Modulo nebulizzata
 Nebulised module
 Module nébulisé
 Modul Zerstäuber
 Módulo nebulización
 Модуль распыление
 Στοιχείο καταιονισμού
 雾化模块

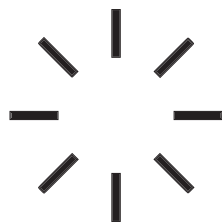

Modulo cromoterapia
 Chromotherapy module
 Module chromothérapie
 Farbtherapie-modul
 Módulo cromoterapia
 Модуль хромотерапии
 Στοιχείο χρωματοθεραπείας
 色疗模块



Modulo musica
 Music module
 Module musique
 Musik-modul
 Módulo música
 Модуль музыки
 Στοιχείο μουσικής
 音乐模块

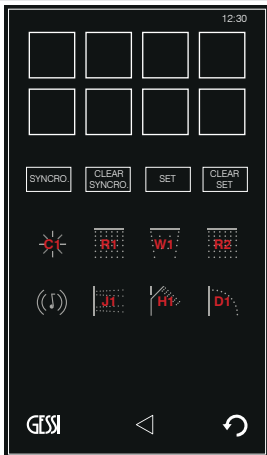
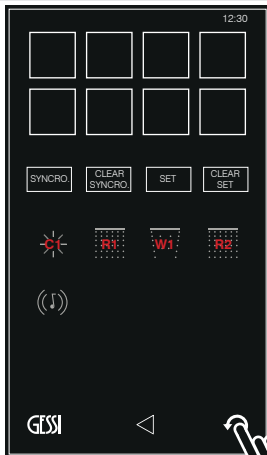

- Premere per aggiornare la schermata e far comparire le icone dei moduli a parete (compariranno solo se impostati, vedere sezione "identificazione moduli a parete")
- Press to update the screen and display the wall module icons (they will appear only if set, see section "identification wall modules")
- Appuyer pour mettre à jour l'écran et visualiser les icônes des modules à paroi (elles n'apparaîtront que si elles ont été programmées, voir la section "identification modules à paroi")
- Drücken, um den Bildschirminhalt zu aktualisieren und damit die Ikonen der Wandmodule erscheinen (diese erscheinen nur, wenn es eingestellt worden ist, hierzu siehe unter Abschnitt "Identifizierung der Wandmodule")
- Pulsen para actualizar la pantalla y visualizar los iconos de los módulos de pared (comparcerán sólo si configurados, ver sección "Identificación módulos de pared")
- Нажмите, чтобы обновить экран и отобразить иконки настенных модулей (они появятся, только если настроены, см. раздел "Идентификация настенных модулей")
- Πατήστε για να επικαιροποιήσετε την οθόνη και να εμφανίσετε τις εικόνες των επιτοιχίων στοιχείων (θα εμφανιστούν μόνον εάν ρυθμιστούν, βλέπε τμήμα "προσδιορισμός επιτοιχίων στοιχείων")
- 按，以更新页面并让墙装式模块的图标出现（只有设置过时才会出现，参见“墙装式模块识别”章节）

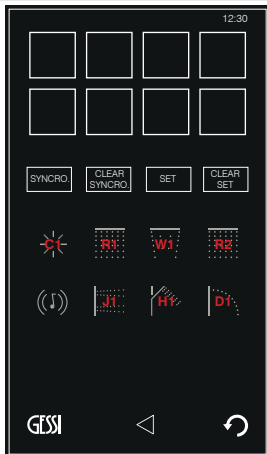

- Impostare a piacimento l'ordine dei moduli che verrà visualizzato nella schermata iniziale
- Set the order of the modules to be displayed on the initial screen as desired
- Programmer l'ordre des modules qui sera visualisé sur l'écran initial
- Stellen Sie die Reihenfolge der Module ein, die auf dem Einstiegsbild angezeigt werden sollen
- Configurar según deseo la secuencia de los módulos que irán a ser visualizados en la pantalla inicial
- Установите желаемый порядок модулей, отображающихся на главной странице
- Ρυθμίστε όπως προτιμάτε την σειρά των στοιχείων που θα προβληθεί στην αρχική οθόνη
- 随意设置开始页面上显示的模块顺序

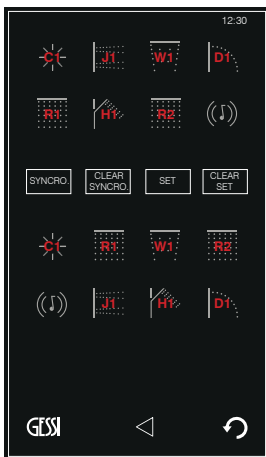
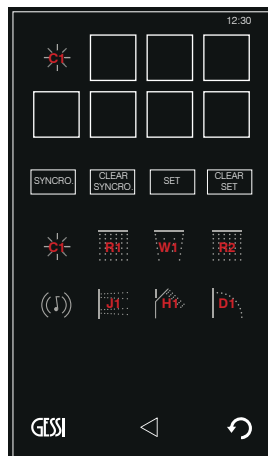
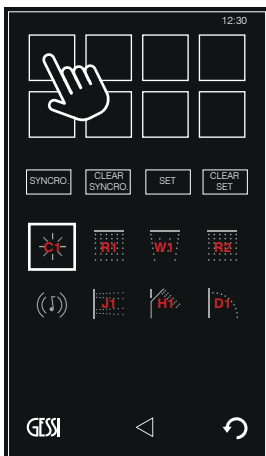
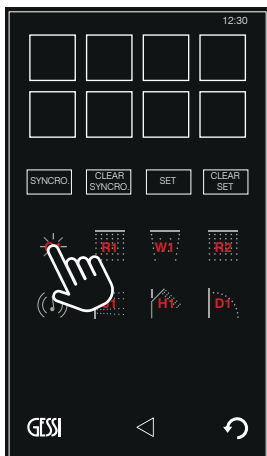

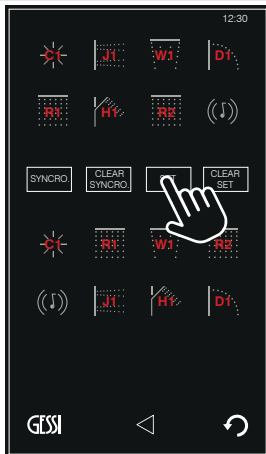

SET

- Premere per confermare e salvare la selezione
- Press to confirm and save the selection
- Appuyer pour confirmer et sauver le choix
- Drücken, um die Wahl zu bestätigen und zu sichern
- Pulsen para confirmar y guardar la selección
- Нажмите, чтобы подтвердить и сохранить выбор
- Πατήστε για να επιβεβαιώσετε και να αποθηκεύσετε την επιλογή
- 按，以确认和保存所做选择

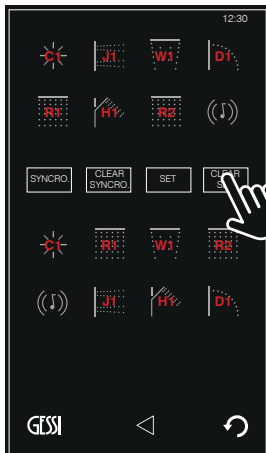

CLEAR SET

- Premere per cancellare la selezione
- Press to delete the selection
- Appuyer pour effacer le choix
- Drücken, um die Wahl zu löschen
- Pulsen para cancelar la selección
- Нажмите, чтобы отменить выбор
- Πατήστε για να ακυρώσετε την επιλογή
- 按，以删除所做选择

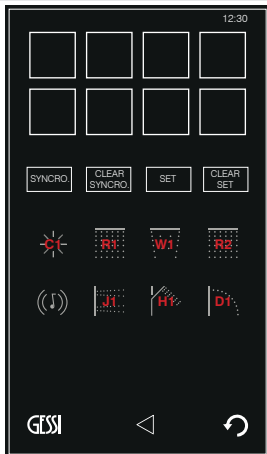

- E' possibile combinare due o più moduli uguali in un'unica icona di comando
- It is possible to combine two or more identical modules in a single control icon
- Il est possible de combiner deux ou plus modules identiques dans une seule icône de commande
- Es ist möglich, zwei oder mehr identische Module in einem einzigen Befehlsymbol zu kombinieren
- Es posible combinar dos o más módulos iguales en un único icono de mando
- Можно объединить два или больше одинаковых модуля в одну иконку
- Είναι δυνατόν να συνδυάσετε δύο ή περισσότερα ίδια στοιχεία σε μία ενιαία εικόνα εντολής
- 可以将两个或多个一样的模块与同一个控制图标关联

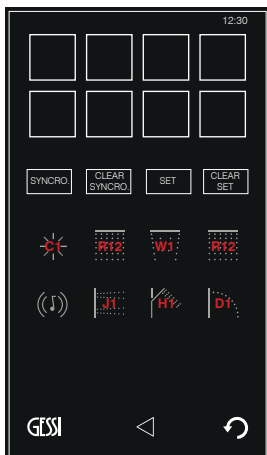
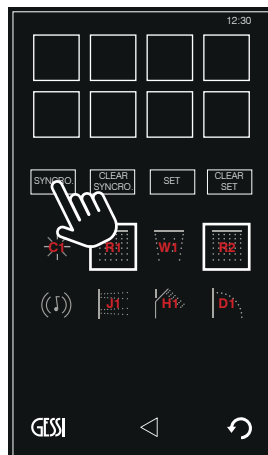
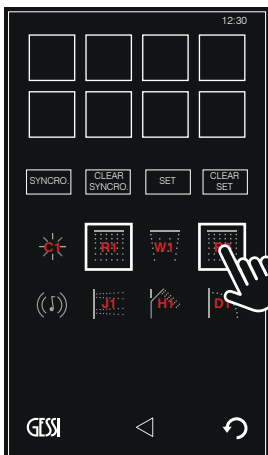
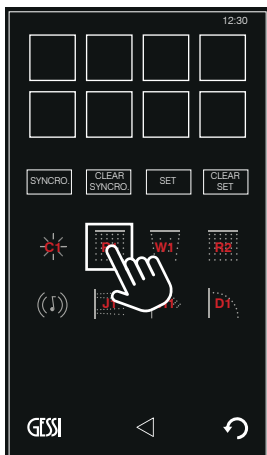

- Proseguire ad impostare l'ordine dei moduli come spiegato in precedenza
- Continue setting the order of the modules as previously explained
- Continuer à définir l'ordre des modules (voir les explications ci-dessus)
- Setzen Sie die Reihenfolge der Module wie oben beschrieben fort
- Sigant configurando la secuencia de los módulos como anteriormente explicado
- Продолжайте устанавливать порядок модулей, как описано выше
- Συνεχίστε την ρύθμιση της σειράς των στοιχείων όπως επεξηγήθηκε προηγουμένως
- 按照前面的说明继续进行模块顺序的设置

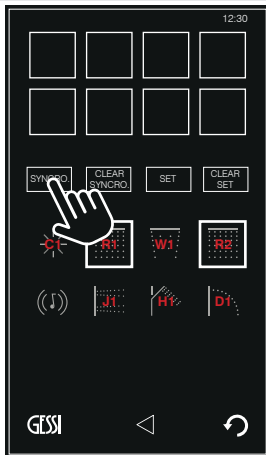

SYNCRO

- Premere per confermare l'abbinamento
- Press to confirm the combination
- Appuyer pour confirmer le couplage
- Drücken, um die Kombination zu bestätigen
- Pulsen para confirmar el acoplamiento
- Нажмите, чтобы подтвердить комбинацию
- Πατήστε για να επιβεβαιώσετε τον συνδυασμό
- 按，以确认关联

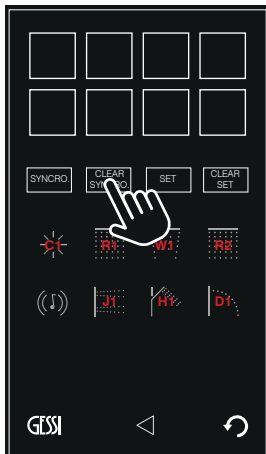

CLEAR SYNCRO

- Premere per cancellare tutti gli abbinamenti eseguiti
- Press to delete all the performed combinations
- Appuyer pour effacer tous les couplages effectués
- Drücken, um alle durchgeführten Kombinationen zu löschen
- Pulsen para cancelar todos los acoplamientos ejecutados
- Нажмите, чтобы отменить все комбинации
- Πατήστε για να ακυρώσετε όλους τους συνδυασμούς που έχουν εκτελεστεί
- 按，以删除所有已经完成的关联



Fig. 35

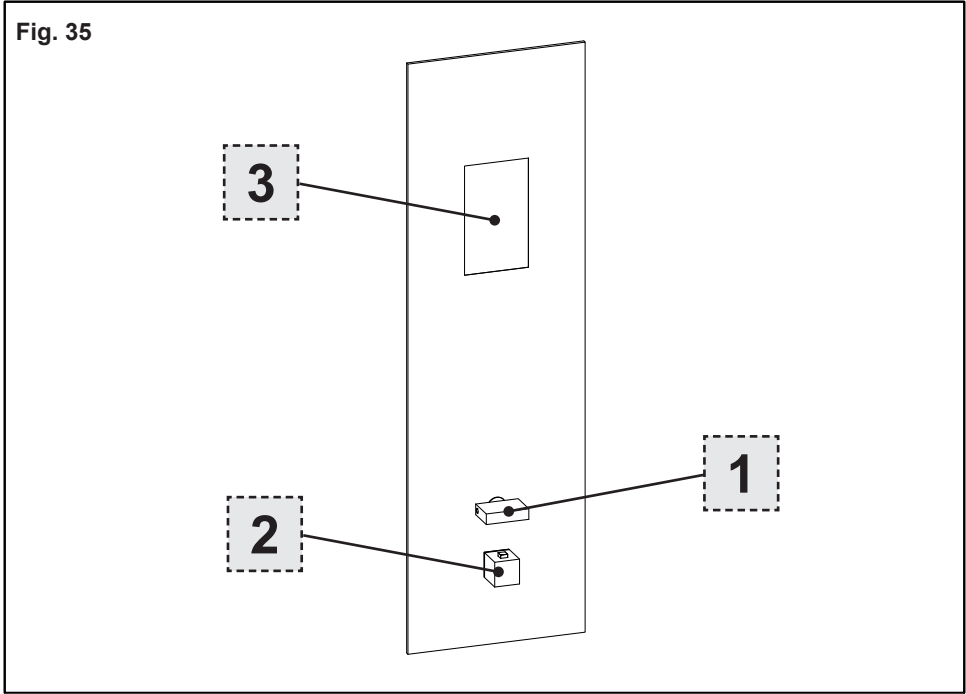

- 1 - Comando per la regolazione della portata
- 2 - Comando per la regolazione della temperatura
- 3 - Touch screen

- 1 - Кран подачи воды
- 2 - Регулятор температуры
- 3 - Сенсорный экран

- 1 - Flow rate adjustment control
- 2 - Temperature adjustment control
- 3 - Touch screen

- 1 - Εντολή για τη ρύθμιση της παροχής
- 2 - Εντολή για τη ρύθμιση της θερμοκρασίας
- 3 - Οθόνη αφής

- 1 - Commande pour le réglage du débit
- 2 - Commande pour le réglage de la température
- 3 - Touch screen

- 1 - 水流控制裝置
- 2 - 溫度控制裝置
- 3 - 触摸屏

- 1 - Steuerung für die Einstellung des Wasserdurchflusses
- 2 - Steuerung für die Temperatureinstellung
- 3 - Touch screen

- 1 - Mando para la regulación del caudal
- 2 - Mando para la regulación de la temperatura
- 3 - Touch screen



1

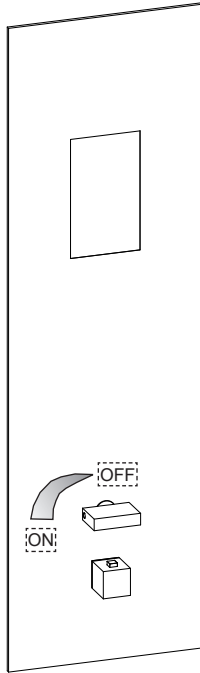

2

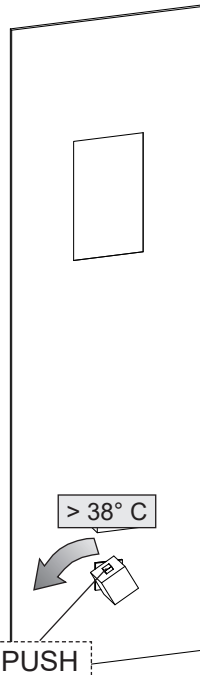
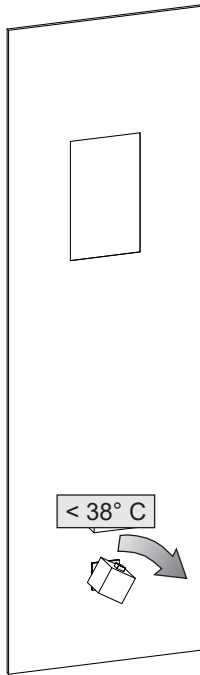
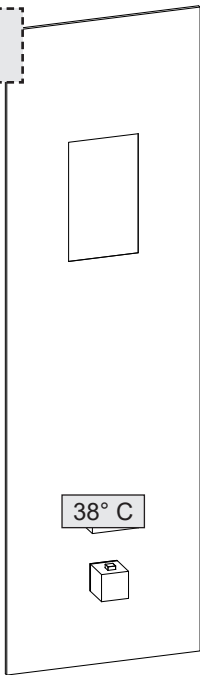



3

ATTENZIONE: per il funzionamento del touch screen vedere il manuale specifico incluso nella confezione.

ATTENTION: consult the specific handbook regarding the touch screen functioning, included in the package.

ATTENTION: pour le fonctionnement du touch screen voir le manuel inclus dans l'emballage.

ACHTUNG: Informationen zur Bedienung des Touchscreens finden Sie in der Bedienungsanleitung, die im Lieferumfang enthalten ist.

CUIDADO: para el funcionamiento del touch screen vean el manual específico incluido en el embalaje.

ВНИМАНИЕ: функционирование сенсорного экрана описано в соответствующем руководстве, которое прилагается.

ΠΡΟΣΟΧΗ: για την λειτουργία της οθόνης αφής δείτε το ειδικό εγχειρίδιο που περιλαμβάνεται εντός της συσκευασίας.

注意: 就触摸屏的运行请参见包装内含专用手册。



MANUTENZIONE

- Nel caso sia necessario sostituire uno o più componenti, contattare un rivenditore autorizzato o visitare il sito WWW.GESSI.COM
- Affidare la manutenzione del prodotto a personale qualificato

MAINTENANCE

- Should it be necessary to replace one or more components, contact an authorized retailer or visit WWW.GESSI.COM
- Product maintenance should be made only by qualified staff

ENTRETIEN

- S'il est nécessaire de remplacer un ou plusieurs composants, contacter un centre autorisé ou visiter le site WWW.GESSI.COM
- L'entretien du produit ne doit être effectué que par du personnel qualifié

WARTUNG

- Falls das Auswechseln von einem oder mehreren Bestandteilen erforderlich wird, kontaktieren Sie bitte einen autorisierten Fachhandel oder besuchen Sie unsere Website unter WWW.GESSI.COM
- Die Instandhaltung des Produktes sollte nur qualifiziertem Personal anvertraut werden.

MANUTENCIÓN

- En el caso de que sea necesario remplazar uno o más componentes, contacten con un revendedor autorizado o visiten el sitio WWW.GESSI.COM
- Encarguen sólo a personal calificado para el mantenimiento del producto

ОБСЛУЖИВАНИЕ

- В случае если будет необходимо заменить один или несколько компонентов, обратитесь к авторизованному дистрибьютору или посетите веб-сайт WWW.GESSI.COM
- Обслуживание изделия должен выполнить квалифицированный персонал.

ΣΥΝΤΗΡΗΣΗ

- Σε περίπτωση που είναι απαραίτητο να αντικαταστήσετε ένα ή περισσότερα εξαρτήματα, επικοινωνήστε με ένα εξουσιοδοτημένο κατάστημα πώλησης ή επισκεφθείτε τον ιστότοπο WWW.GESSI.COM
- Εμπιστευθείτε τη συντήρηση του προϊόντος σε διαπιστευμένο προσωπικό

保养

- 若需替换一个或者多个部件，请联系授权分销商或浏览WWW.GESSI.COM网站
- 请让合格人士负责产品保养工作

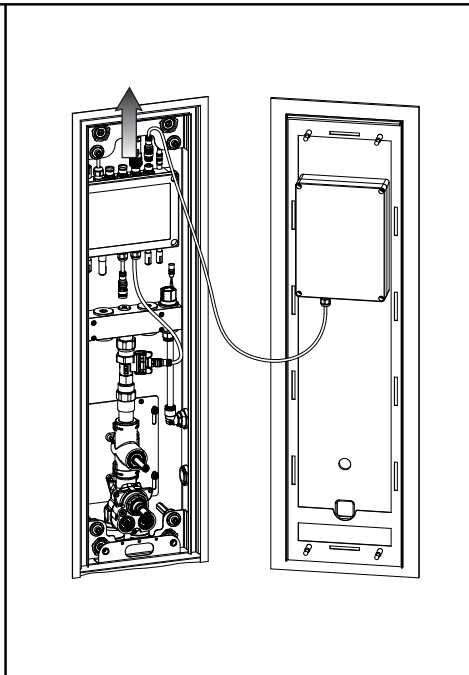
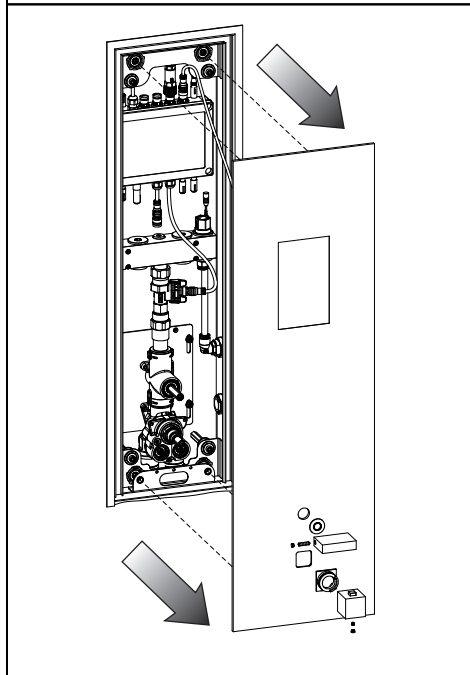
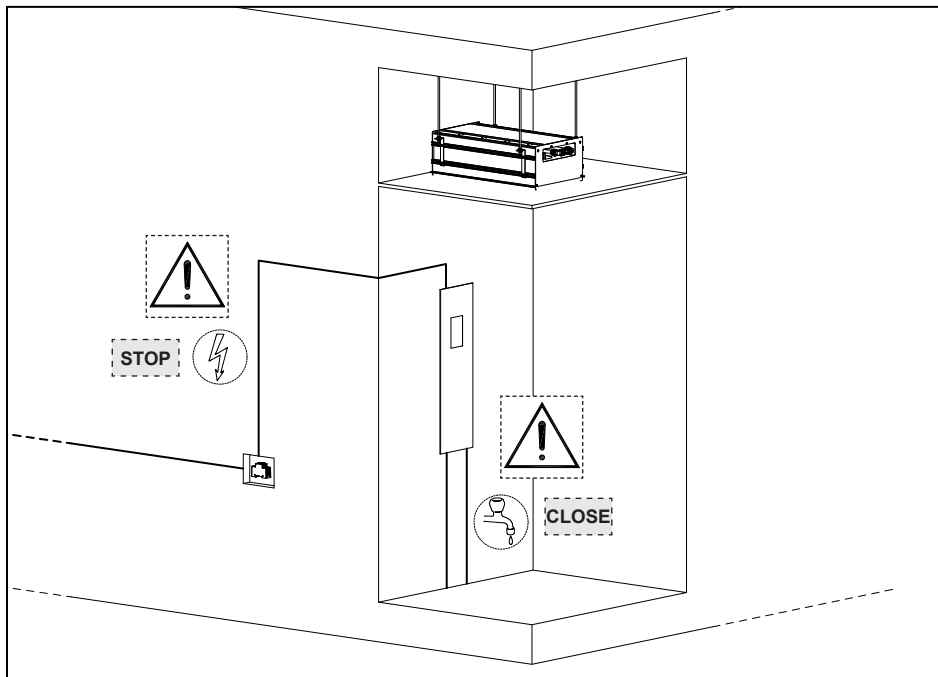

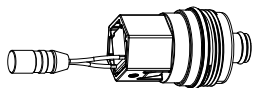

Fig. 1

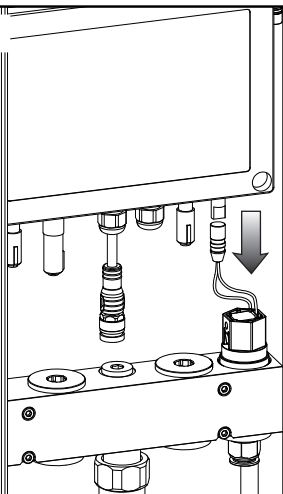
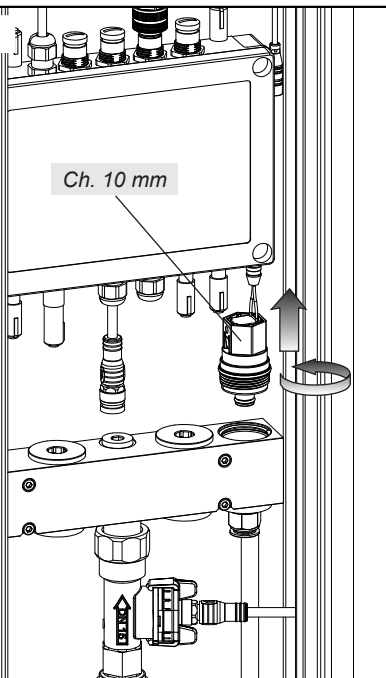

Fig. 2



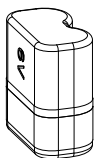

Fig. 1

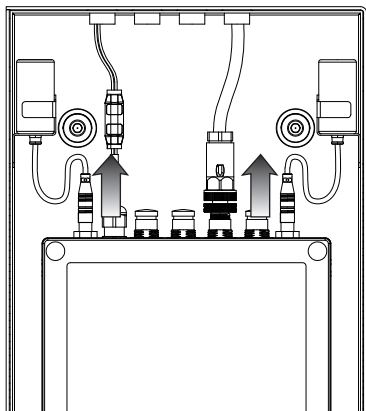

Fig. 2

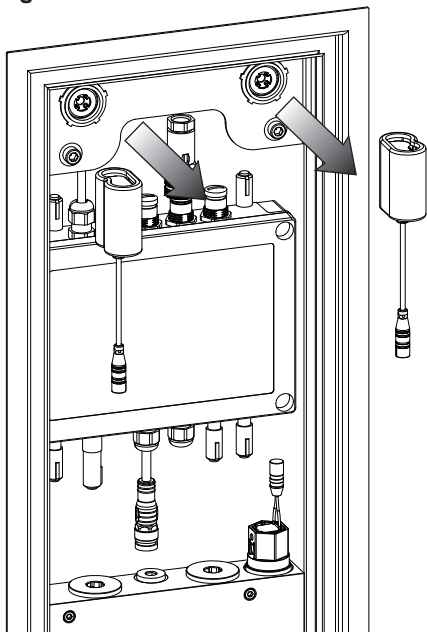
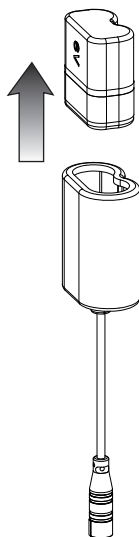

Fig. 3



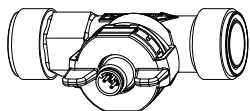

Fig. 1

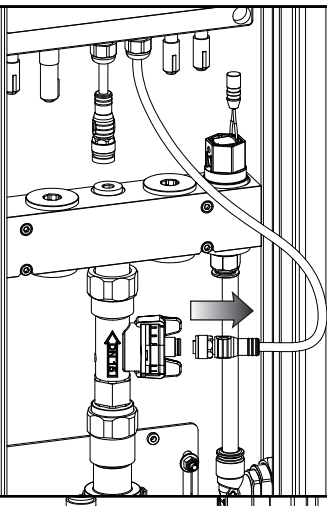

Fig. 2

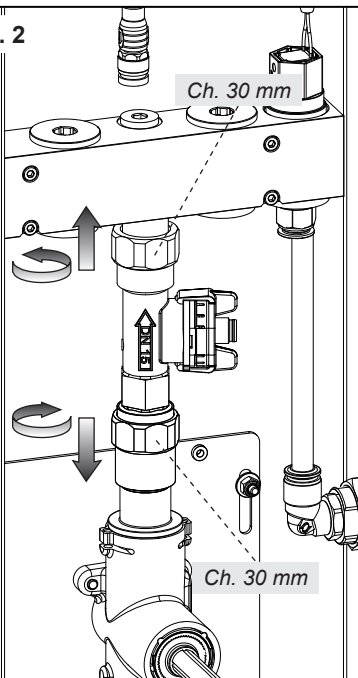
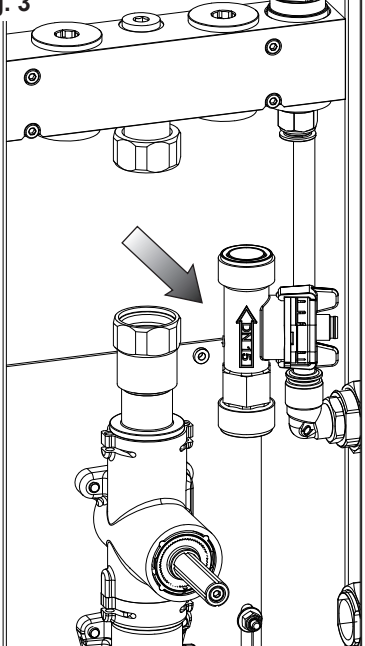

Fig. 3



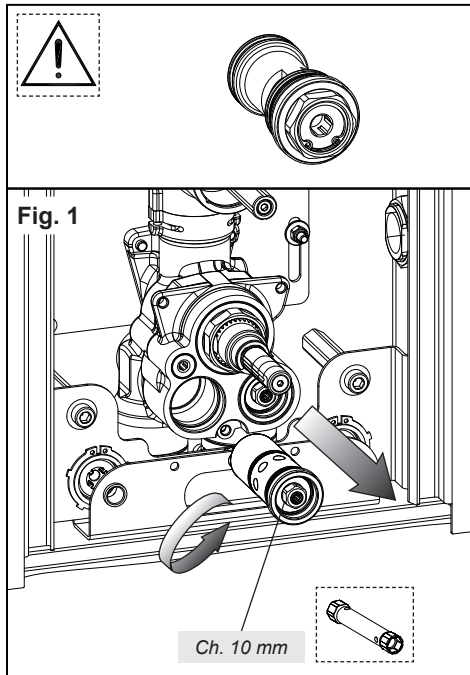

Fig. 2

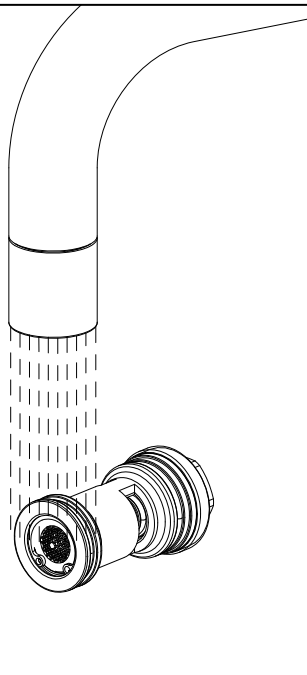
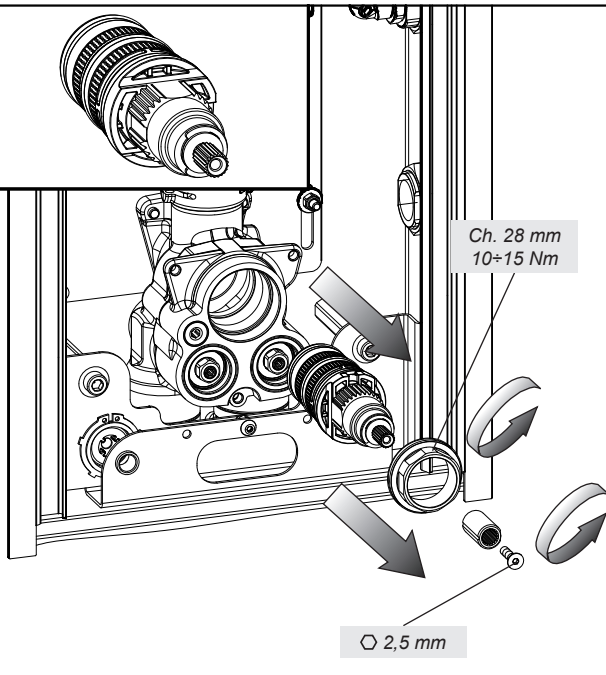



Fig. 1



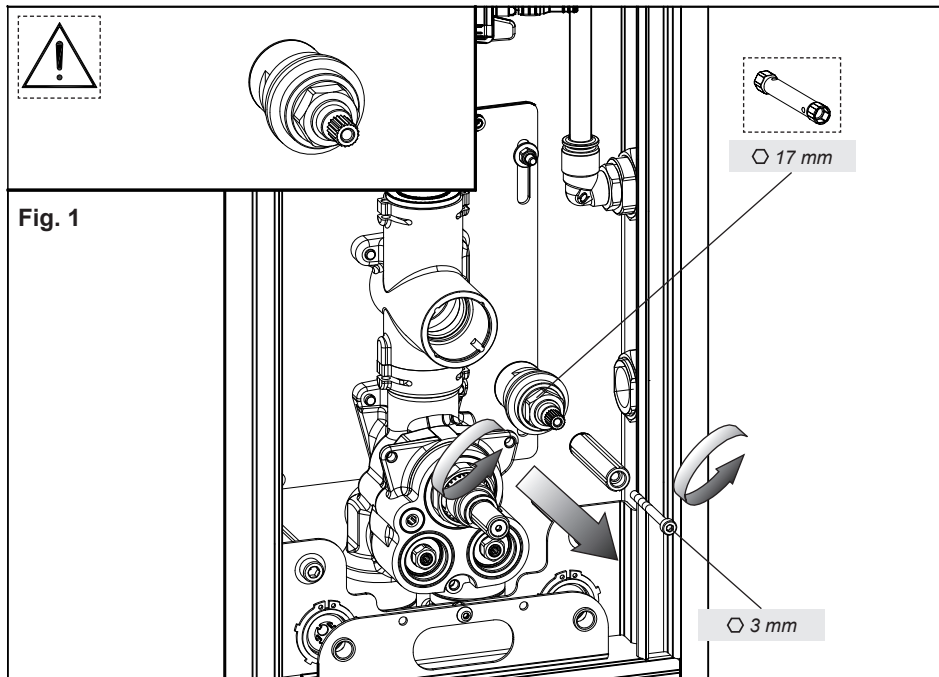



Fig. 2

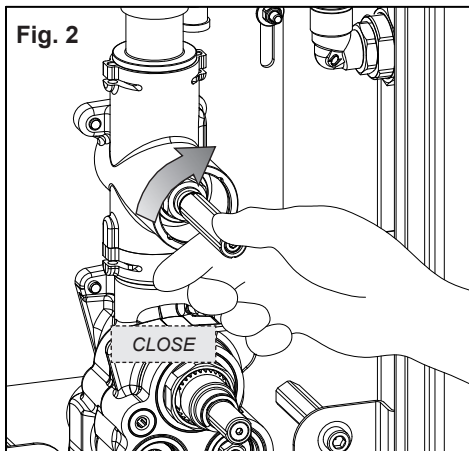

Fig. 3

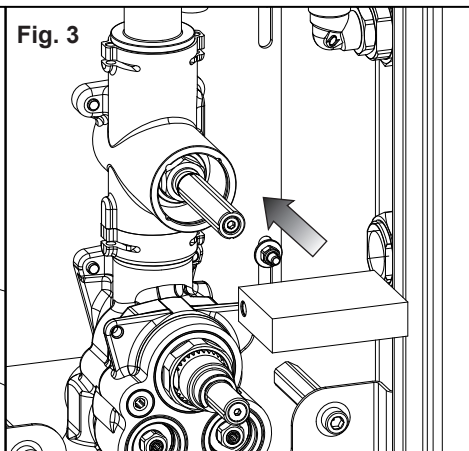

Fig. 4

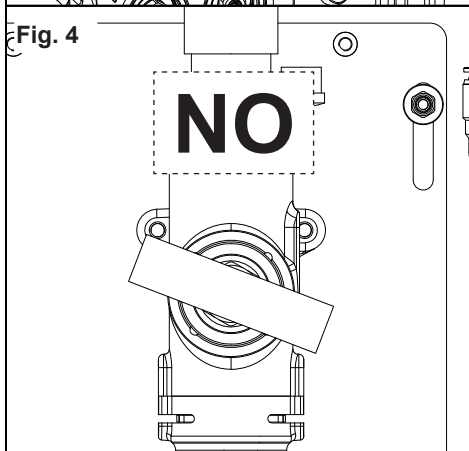

Fig. 5

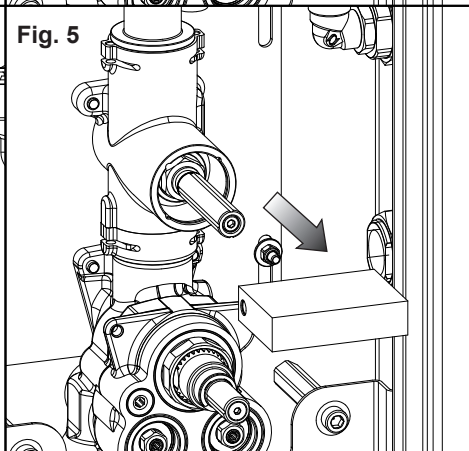

Fig. 6

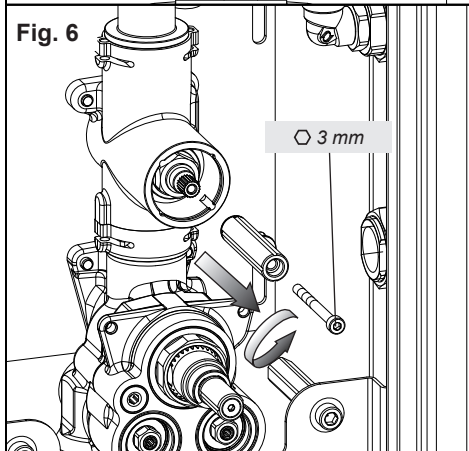

Fig. 7

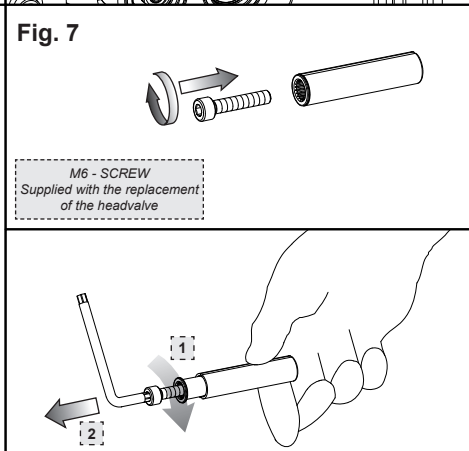



Fig. 8

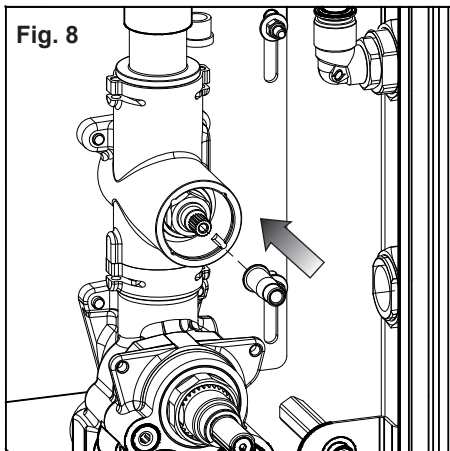

Fig. 9

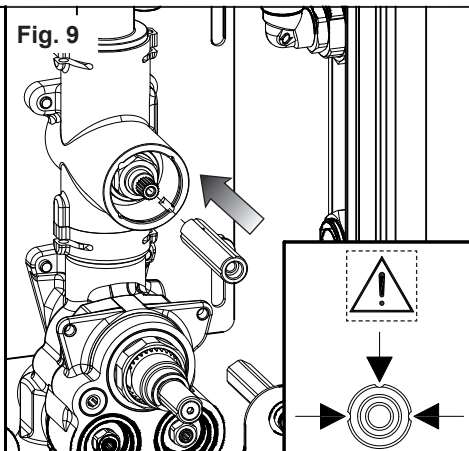

Fig. 10

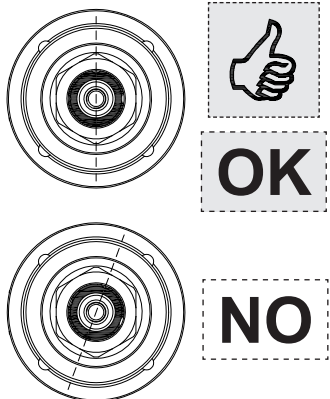

Fig. 11

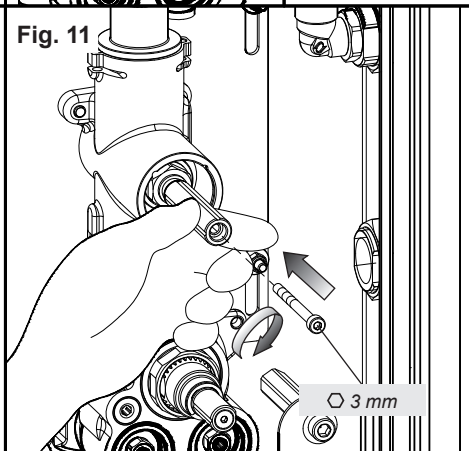

Fig. 12

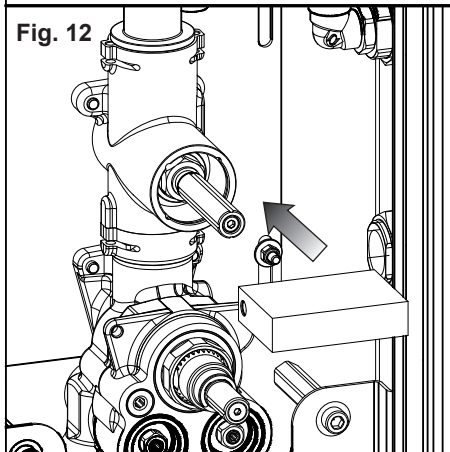

Fig. 13

