

### General description



**KG0020B**  
Matte black epoxy finish

- Glove dispenser holder designed for the Mediclinics mobile hand sanitizing station, code HGPT0020B, made of black epoxy painted steel.
- This glove dispenser holder is the perfect complement to the Mediclinics' hand sanitizing station holder so that gloves can also be provided to the public.
- Compatible with most disposable glove boxes on the market.
- Ideal for use in high traffic places such as airports, hospitals, shopping malls, schools, hotels and restaurants, museums, libraries, etc.
- It has a mechanical glove box retention system that prevents movement and makes it easy for the user to remove the gloves.
- It can be easily mounted on the pole, in two different positions, depending on whether a vertical or horizontal glove extraction is desired. Only one hex key is required.
- It has 4 additional slots that allow wall mounting (wall fixing means are not included)
- This glove dispenser holder helps maintain hygiene and disinfection.

### Components and materials

- **GLOVE BOX RETAINER:** made of steel, 1.5 mm thick, matte black epoxy finish. It has two slots for the horizontal pole mounting.
- **BACK PLATE:** made of steel, 1.5mm thick matte black epoxy finish. It has two slotted holes for vertical pole mounting and 4 circular holes for wall mounting. It has a mechanical system for the retention of the glove box that prevents its movement within the support.
- **ASSEMBLY TOOLING:** Includes 2 screws for pole mounting.

### Technical specifications

<b>Dimensions</b>	262x144x87mm
<b>Glove dispenser holder thickness</b>	1.5mm
<b>Maximum glove box dimensions</b>	260x140x80mm
<b>Net weight</b>	1.1Kg

### Dimensions

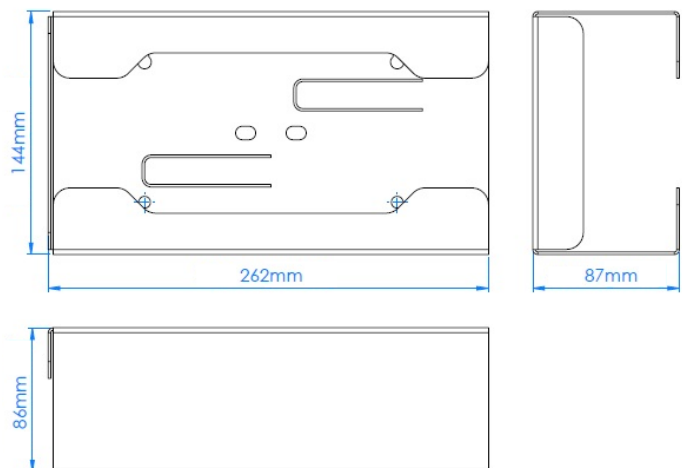

Dimensions:  $\pm 4\%$