

Art.: 3570

Válvula escuadra gas H-H. Mando palomilla / F-F gas square valve. Butterfly handle

Características	Features
1. Construcción latón según UNE-EN 12164 -12165.	1. Brass according to UNE-EN 12164 - 12165.
2. Acabado superficial cromado.	2. Chrome-plated surface finishing.
3. Juntas en NBR según EN 549.	3. NBR joints according to EN 549.
4. Extremos rosca hembra-hembra s/ ISO 7/1 (EN 10226-1).	4. Thread ends female-female acc. to / ISO 7/1 (EN 10226-1).
5. Garantizada para el uso de Gas Natural.	5. Guaranteed for the use of Natural gas.
6. Temperatura de trabajo: de -40°C a 60°C.	6. Work temperature: from -40°C to 60°C.
7. Las válvulas se pueden bloquear y precintar.	7. The valves can be blocked and sealed.
8. Eje con doble junta tórica.	8. Stem with double o-ring.
9. Mando palomilla aluminio precintable.	9. Sealeable aluminium butterfly handle.
10. Sellado de cuerpo y tapa mediante adhesivo y junta tórica.	10. Body and cap sealed by means adhesive and o-ring.
11. Especificaciones según norma UNE-EN 331.	11. Requirements according to European Standard UNE-EN 331.

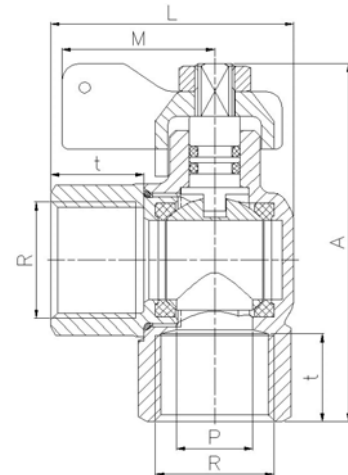
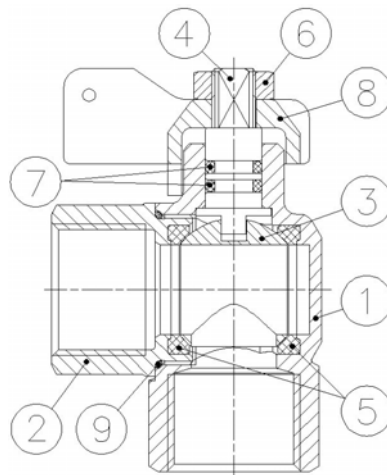

Nº	Denominación / Name	Material	Acabado Superficial / Surface Treatment
1	Cuerpo / Body	Latón / Brass (CW617N)	Granallado + Cromado / Peened + Chromed
2	Tapa / Cap	Latón / Brass (CW617N)	Granallado + Cromado / Peened + Chromed
3	Esfera / Ball	Latón / Brass (CW617N)	Cromado / Chromed
4	Eje / Stem	Latón / Brass (CW614N)	Cromado / Chromed
5	Asientos / Ball seats	PTFE	-
6	Tuerca / Nut	Latón / Brass (CW614N)	Cromado / Chromed
7	Junta tórica / O-ring	NBR	-
8	Maneta / Handle	Aluminio / Aluminium	Pintado / Painted
9	Junta tórica / O-ring	NBR	-

Ref.	Medida / Size		MOP	Dimensiones / Dimensions (mm)					Peso / Weight (Kg)
	R			P	L	A	M	t	
3570 04	1/2"		5	13,5	43	64,5	27	15,5	0,170