

E23310



Collection: SPIRALE

Finish*:



CP - Chrome

Main features:



Features

- **DIMENSIONS:** 12.70 x 21.50 cm
- **MATERIAL:** Metal
- **TYPE:** Single-lever
- **HEIGHT UNDER SPOUT:** 448
- **CONNECTION:** With supply hoses
- **INSTALLATION TYPE:** 1 hole
- **WEIGHT:** 2.6 kg
- **INSTALLATION TYPE:** 1 hole
- **FLOW RATE:** 7 l/mn
- **SPOUT PROJECTION:** 230
- **MECHANISM:** Cartouche à disques céramique

Consumer benefits

- **EASY CARE:** Anti-scale aerator.
- **WATER EFFICIENT:** Flow rate up to 7 l/min.
- **DockNetik technology** (magnets inside spout) so tap returns securely into place after use.

Technical drawing

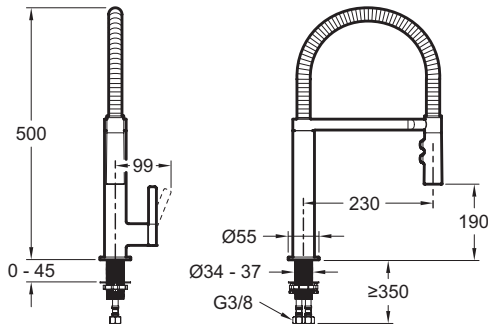

Product Specification: Single-lever kitchen mixer, E23310. Collection: SPIRALE. DIMENSIONS: 12.70 x 21.50 cm. WEIGHT: 2.6 kg. MATERIAL: Metal. INSTALLATION TYPE: 1 hole. TYPE: Single-lever. FLOW RATE: 7 l/mn. HEIGHT UNDER SPOUT: 448. SPOUT PROJECTION: 230. CONNECTION: With supply hoses. MECHANISM: Cartouche à disques céramique. INSTALLATION TYPE: 1 hole.

*Due to possible variations in computer and printer calibrations, technical factors and certain finish characteristics, the colors you see may not accurately portray the actual colors and are provided as a guide only.