

E22T81



Collection: CONTRA

Finish*:



GA - Profils
chromés

Main features:



Features

- **DIMENSIONS:** 200 x 80 cm
- **MATERIAL:** Clear glass
- **MIN/MAX WIDTH WITH SINGLE DOOR:** 76.4 - 78
- **REINFORCING BAR:** Required: horizontal or diagonal.
- **PANEL HEIGHT IN CM:** 200
- **ENCLOSURE TYPE:** Pivot door
- **ANTI-SCALE TREATMENT:** Yes

Consumer benefits

- **COMFORT:** Integral lift mechanism for less seal friction on floor, large handles in chrome metal on both sides
- **ANTI SCALE:** Clear coated glass
- **ACCESSIBILITY:** Extremely wide access to showering area, no threshold strip

Required products

- E22BT: ff
- Barre horizontale fixée à 45°
- Barre horizontale fixée à 90°

- **WEIGHT:** 27 kg
- **INSTALLATION TYPE:** Corner
- **OPENING:** 69
- **GLASS THICKNESS IN MM:** 6
- **WALL ADJUSTMENT IN MM:** 18 mm
- **INSTALLATION:** Close Space
- **WATERTIGHT:** Magnetic door close, door sill supplied

Installation benefits

- **EASY INSTALLATION:** Wall adjustment 18 mm

Optional products

- E22000: Extension profile

Product Specification: Pivot door - reversible. E22T81. Collection: CONTRA. DIMENSIONS: 200 x 80 cm. WEIGHT: 27 kg. MATERIAL: Clear glass. INSTALLATION TYPE: Corner. MIN/MAX WIDTH WITH SINGLE DOOR: 76.4 - 78. OPENING: 69. REINFORCING BAR: Required: horizontal or diagonal.. GLASS THICKNESS IN MM: 6. PANEL HEIGHT IN CM: 200. WALL ADJUSTMENT IN MM: 18 mm. ENCLOSURE TYPE: Pivot door. INSTALLATION: Close Space. ANTI-SCALE TREATMENT: Yes. WATERTIGHT: Magnetic door close, door sill supplied.

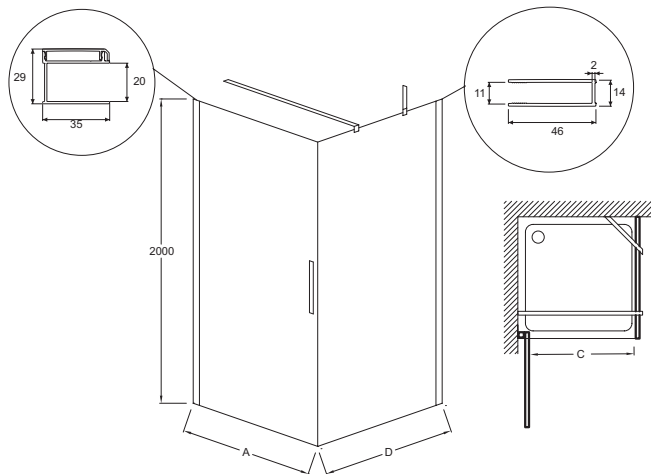

	E22T71	E22T81	E22T91
Mm	700	800	900
A mini/maxi	664 / 682	764 / 782	864 / 882
C	590	690	790

	E22FT70	E22FT80	E22FT90	E22FT100
Mm	700	800	900	1000
D mini/maxi	660 / 680	760 / 780	860 / 880	960 / 980

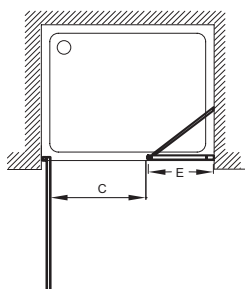
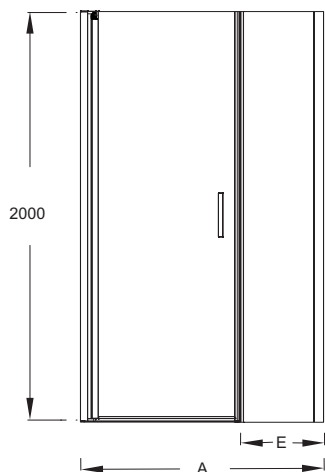

	E22T71+E22L40	E22T81+E22L40	E22T91+E22L40
Mm	1100	1200	1300
A mini/maxi	1064 / 1100	1164 / 1200	1264 / 1300
C	590	690	790
E	400	400	400

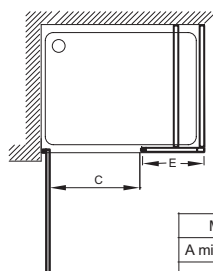
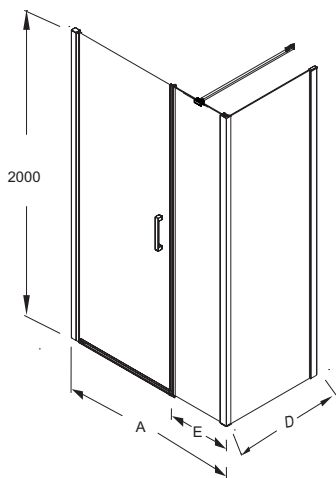

	E22T71+E22L40	E22T81+E22L40	E22T91+E22L40
Mm	1100	1200	1300
A mini/maxi	1064 / 1100	1164 / 1200	1264 / 1300
C	590	690	790
E	400	400	400

	E22FT70	E22FT80	E22FT90	E22FT100
Mm	700	800	900	1000
D mini/maxi	660 / 680	760 / 780	860 / 880	960 / 980

Product Specification: Pivot door - reversible. E22T81. Collection: CONTRA. DIMENSIONS: 200 x 80 cm. WEIGHT: 27 kg. MATERIAL: Clear glass. INSTALLATION TYPE: Corner. MIN/MAX WIDTH WITH SINGLE DOOR: 76.4 - 78. OPENING: 69. REINFORCING BAR: Required: horizontal or diagonal.. GLASS THICKNESS IN MM: 6. PANEL HEIGHT IN CM: 200. WALL ADJUSTMENT IN MM: 18 mm. ENCLOSURE TYPE: Pivot door. INSTALLATION: Close Space. ANTI-SCALE TREATMENT: Yes. WATERTIGHT: Magnetic door close, door sill supplied.