

## AURA SERIES

## Double toilet roll holder with shelf



**AI2004B**  
Black finish



**AI2004C**  
Bright finish



**AI2004CS**  
Satin finish

### General Description

- Double toilet roll holder with shelf to hold mobile phones or other small objects, made of AISI 304 stainless steel, from Mediclinics' Aura series.
- The integrated shelf is ideal to place mobile phones, keys, watch, glasses and other small personal accessory items.
- Ideal for installing in your own home, as well as public-use bathrooms, such as in hotels, bars, restaurants, offices, etc.
- Its arm has stoppers at each end and a slight inclination to prevent the toilet roll from falling off during use.
- Simple, elegant and stylish, this bathroom accessory is suitable for most styles of decoration.
- Made with high-quality, durable and anti-corrosive materials.
- Suitable for most sizes of toilet rolls.
- This bathroom accessory comes with stainless steel hardware for installation on brick walls.

### Components and Materials

- **AI2004B:** double toilet roll holder with shelf made of AISI 304 stainless steel black finish.
- **AI2004C:** double toilet roll holder with shelf made of AISI 304 stainless steel bright finish.
- **AI2004CS:** double toilet roll holder with shelf made of AISI 304 stainless steel satin finish.
- **PAPER ROLL AXIS:** two units made with 3 mm thick AISI 304 stainless steel sheet. Designed with a slight inclination and an end stopper to prevent the roll of paper from falling out during the operation. Fixed to the wall bracket through welding.
- **WALL-SHELF BRACKET:** of one-piece 90° bent, made of 1.5 mm thick AISI 304 stainless steel sheet. The shelf has a 45° fold at its end to avoid falling objects deposited on it.

### Technical Specifications

<b>Dimensions</b>	260 x 85 x 103 mm
<b>Paper roll axis thickness</b>	3 mm
<b>Wall-shelf bracket thickness</b>	1.5 mm
<b>Net weight</b>	600 g

### Dimensions

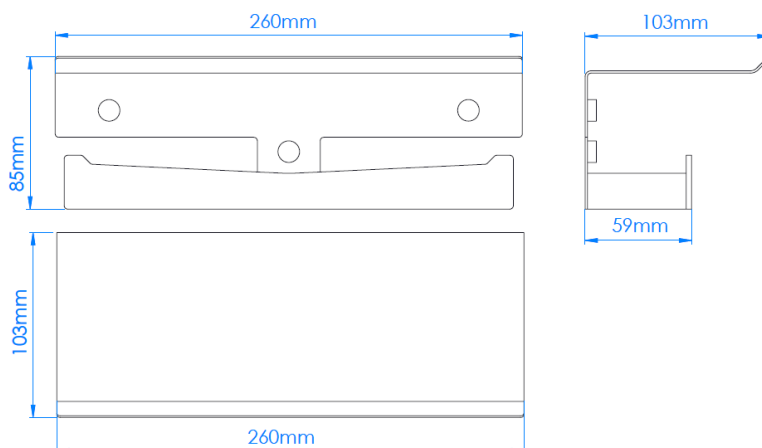

Dimensions: ± 4%