

PROGRAMMA MISCELAZIONE BAGNO
BATH MIXING PROGRAM
PROGRAMME DU MITIGEUR POUR LA SALLE DE BAIN
BAD-MISCHUNGSPROGRAMM
PROGRAMA MEZCLADORES BAÑO
ПРОГРАММА СМЕСИТЕЛЕЙ ДЛЯ ВАННОЙ
ΛΟΥΤΡΟ ΠΟΥ ΑΝΑΜΙΓΝΥΕΙ ΤΟ ΠΡΟΓΡΑΜΜΑ
浴室混水产品

Art. 20023

GESSI 

Gessi SpA - Parco Gessi

13037 Serravalle Sesia (Vercelli) - Italy

Phone +39 0163 454111 - Facsimile +39 0163 459273

www.gessi.com - gessi@gessi.it

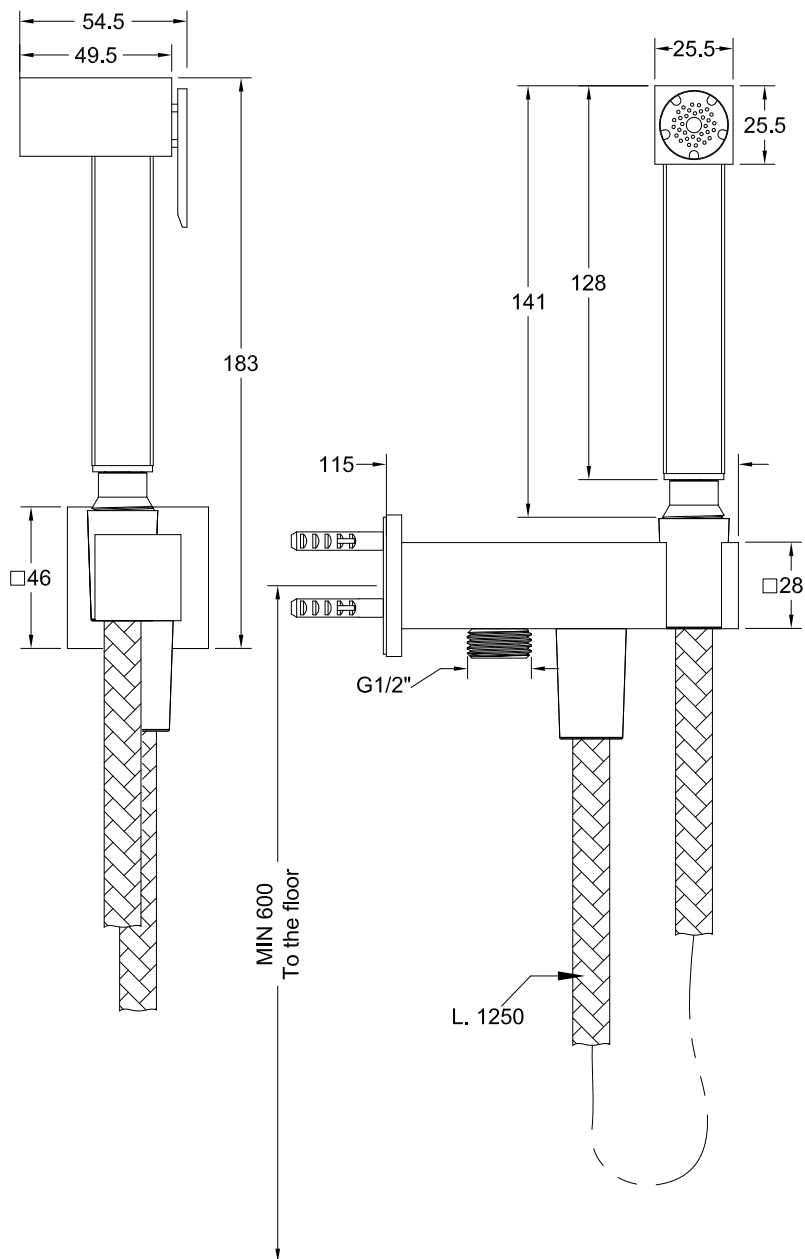

Fig. 1

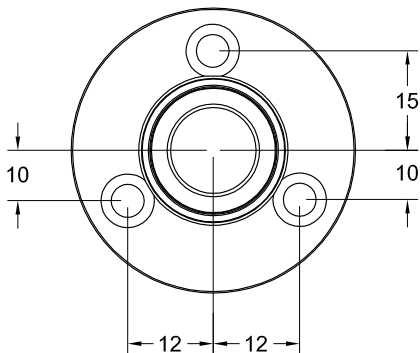

Fig. 2

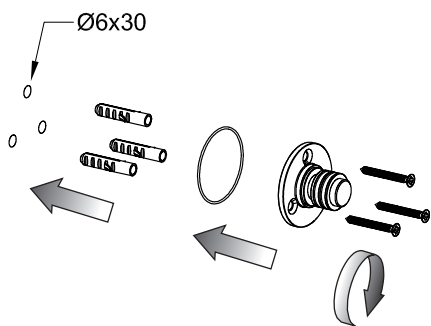

Fig. 3

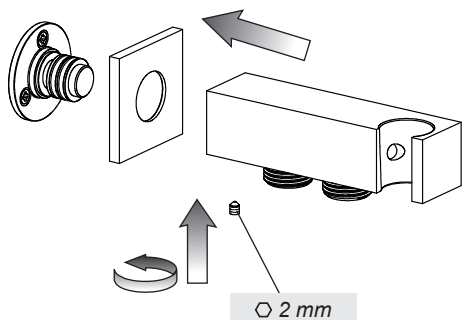
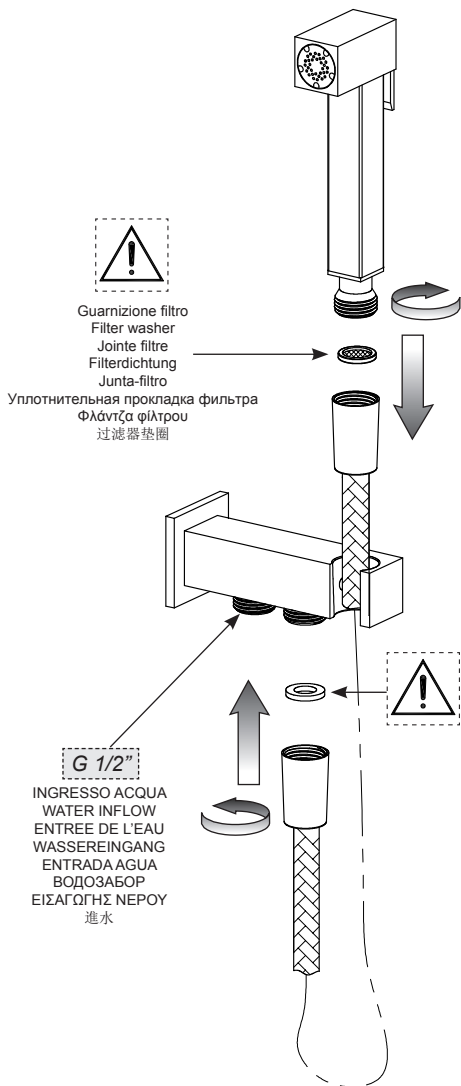
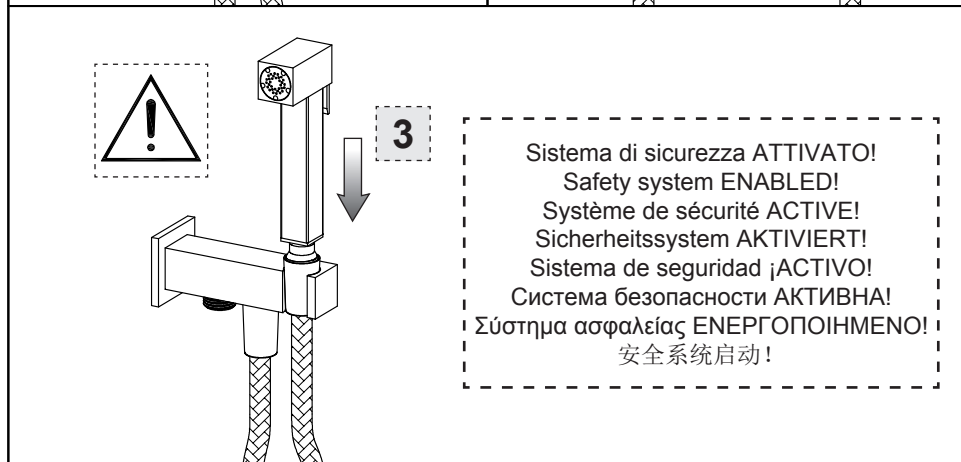
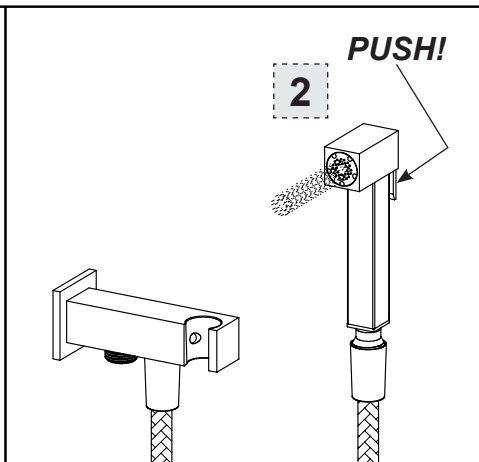
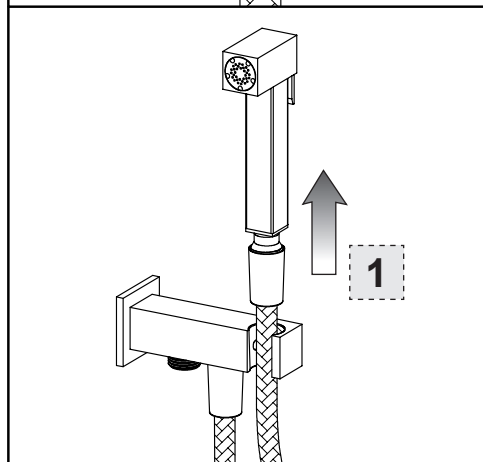
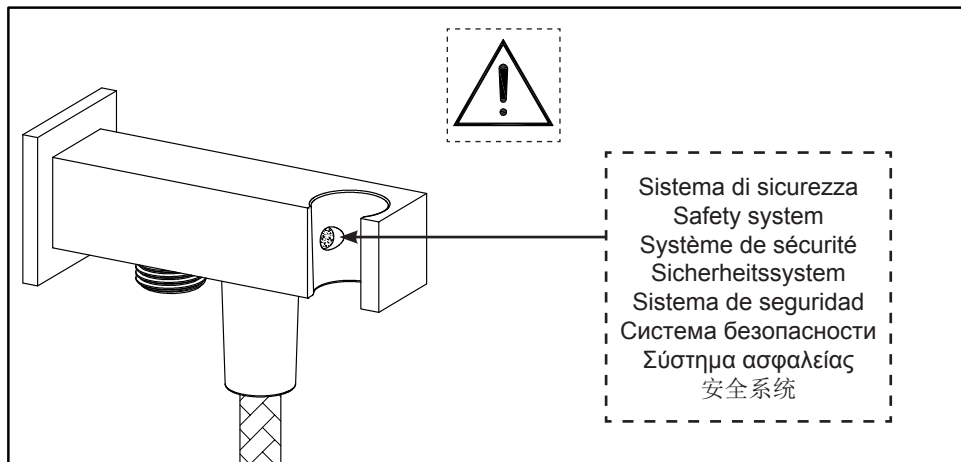

Fig. 4







ATTENZIONE - CAUTION - ATTENTION - ACHTUNG -
CUIDADO - ВНИМАНИЕ - ΠΡΟΣΟΧΗ - 注意



NO!

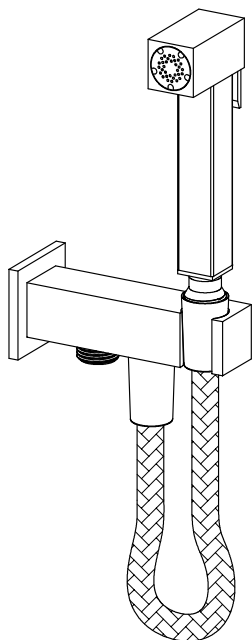
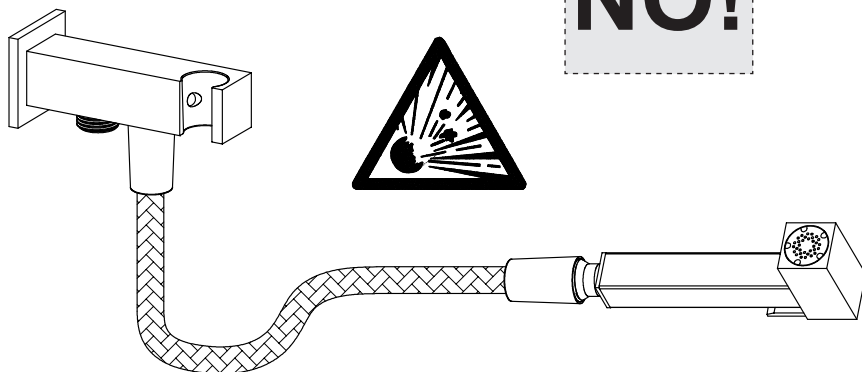

OK!

IMPORTANTE: Dopo l'utilizzo riporre la doccia sul supporto.

IMPORTANT: After use put the hand shower back on the support.

IMPORTANT: Après l'emploi remettre la douche sur le support.

WICHTIG: Die Duschbrause, nach dem Gebrauch, auf ihren Träger stellen.

IMPORTANTE: Después de su utilización vuelvan a colocar la ducha-teléfono en el soporte.

ВАЖНО: После использования снова положите на опору ручной душ.

ΣΗΜΑΝΤΙΚΟ: Μετά τη χρήση τοποθετήστε το τσουάκι στη βάση του.

重要: 使用之后将手持式花洒放回支座上.

A series of horizontal dotted lines for writing notes, spanning the width of the page.

