

NAN A-3040LX

wall lamp

Date	Type
Project	
Location	
Model #	Quantity
Specifier	

Description

Wall lamp providing direct and indirect light.
Satinated polyethylene shade.
Highly-resistant paint for maximum outdoor protection.

Installation

Suitable for outdoor and indoor locations.



Pictures above might not show the specified dimensions or material. They are for illustration purposes only.



Ordering information

Product Code	Lamp	Finish
■ A-3040LX	■ LED 20W (2700K / Ang 120° / >80 CRI) 230V (included) / Typ* 1700 lumens Dimmable Triac	■ 79 WH L White ■ CUSTOM

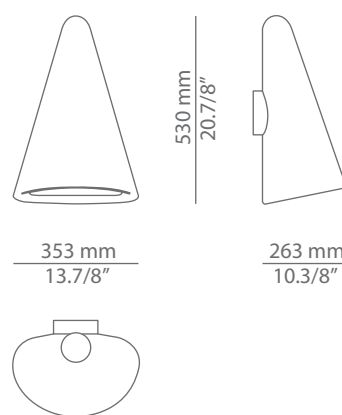

SPECIAL REQUIREMENTS

Custom finishes and versions

Alternate lamping available for projects. Consult our offices.

Special instructions
