

MIRROR CUPBOARD SENSOR SOAP/PAPER WP650E



600 x 600 x 130 mm

950 ml sensor soap, 750 paper towels

- Mirror cupboard with integrated sensor liquid soap dispenser and paper towel dispenser in robust, germ-reducing and easy-care stainless steel (AISI 304).
- All-stainless steel housing; visible surfaces satin finished and brushed.
- Crystal mirror with all round 2 mm chamfer and frosted window for optional lighting set.
- Sensor liquid soap dispenser with EWAR® eModule touch-free operated soap pump.
- Designed for standard 950 ml disposable bottles of liquid soap or hand lotion.
- Also refillable with large container using the plug-in tank as an option.
- Paper towel dispenser with deep-drawn paper removal opening for easy paper removal.
- Designed for approx. 750 standard paper towels in zigzag fold. Paper size (folded): 240-250 mm x 100-115 mm.
- Accessible for refilling through lockable door.
- Keyed alike cylinder lock in corrosion-resistant zinc die-casting.
- eModule battery-powered with two 1.5 V Baby/LR14 batteries. Power supply available as an option.
- Wear parts can be replaced as modules.
- Mounting: With four screws through key holes and one optional anti-theft hole in the back wall.
- Delivery includes fixing material, batteries, first fill with soap and one pack of paper towels.
- Weight, including single package: 20.0 kg

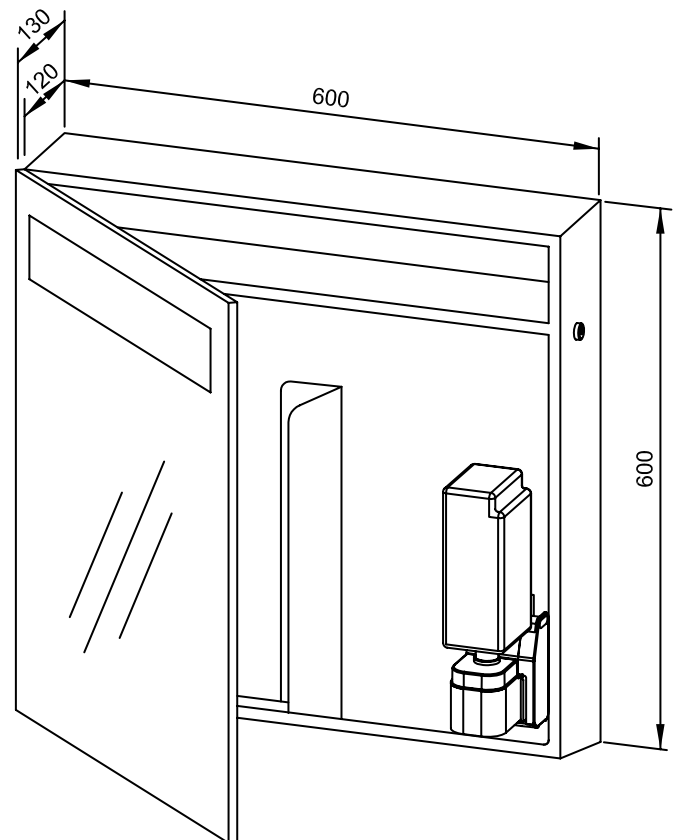

Suggested text for specifications:

Mirror cupboard with integrated sensor liquid soap dispenser and paper towel dispenser in stainless steel (AISI 304) for surface mounting. All-stainless steel housing; visible surfaces satin finished and brushed. Crystal mirror with all round 2 mm chamfer and frosted window for optional lighting set. Sensor liquid soap dispenser with touch-free operated soap pump. Designed for standard 950 ml disposable bottles of liquid soap or hand lotion. Paper towel dispenser with deep-drawn paper removal opening, filling quantity approx. 750 paper towels. Accessible for refilling through lockable door. Keyed alike cylinder lock in corrosion-resistant zinc die-casting. Delivery includes fixing material, batteries, first fill with soap and one pack of paper towels.

Dimensions: 600 x 600 x 130 mm

Article No. WP650e

Available surface	ID No.
satin finished	727 891

Options	ID No.
Power supply for eModule	923 060
Lighting set	727 893

Ernst Wagner GmbH & Co. KG

Ernst-Abbe-Straße 21 · D-72770 Reutlingen · Tel.: +49712151539-0 · Fax: -20
info@wagner-ewar.de · www.wagner-ewar.de

WAGNER
EWAR