

ARTICOLO / Item
Artículo / Article / Artikel

02582S

Erogatore di sapone completo; a comando elettronico e alimentazione a rete 230V.

Soap dispenser, complete, infra-red sensor operated and powered by mains 230V.

dosificador de jabón; con sensores infrarrojos y alimentación de red 230V

distributeur de savon; avec capteurs infrarouges et alimentation sur secteur 230V.

Seifenspender, komplett; mit Infrarotsensor und Netzanschluss 230V.

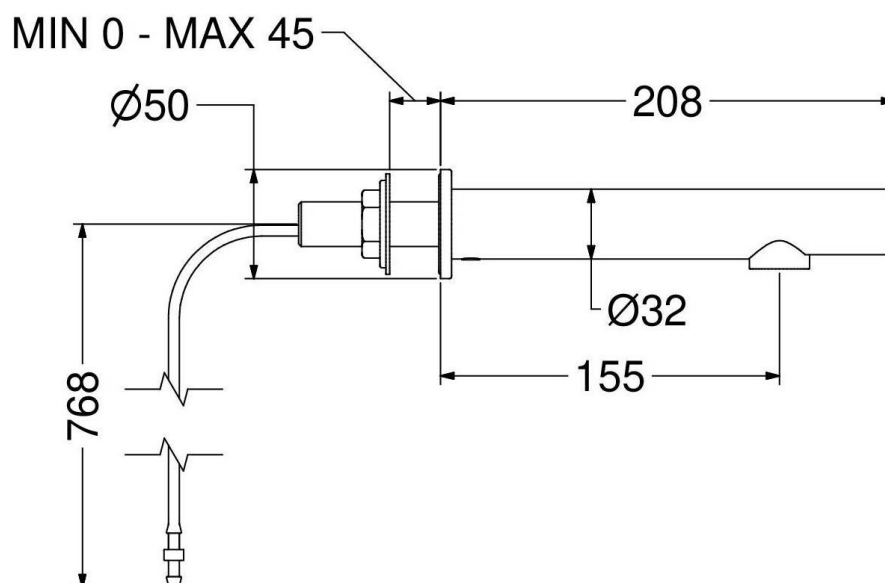

SERBATOIO SAPONE/ SOAP TANK/CISTERNA DE JABÓN/RÉSERVOIR DE SAVON/ SEIFENTANK

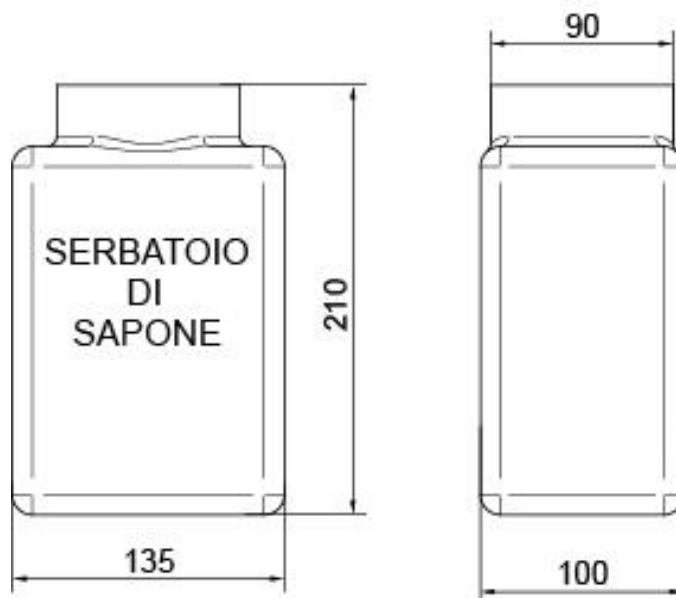

DISTRIBUTORE SAPONE/ SOAP DISTRIBUTOR/DISPENSADOR DE JABÓN / DISTRIBUTEUR DE SAVON/ SEIFENVERTEILER

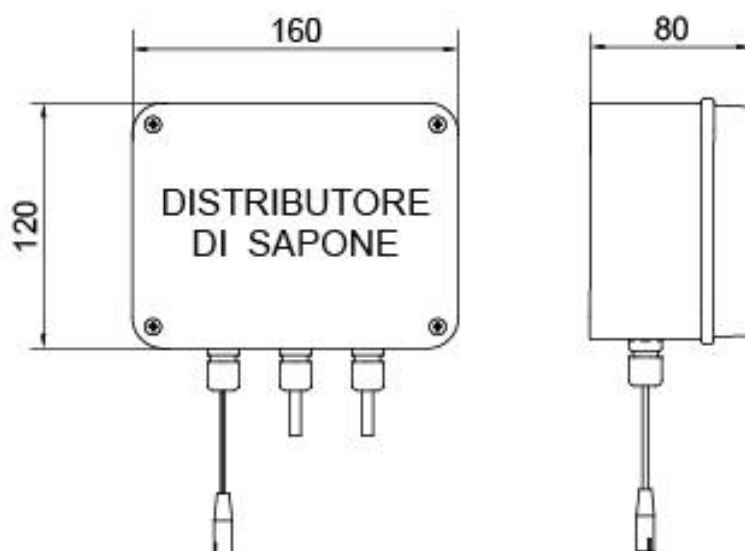

**ALIMENTATORE SINGOLO INCASSO/ CONCEALED POWER SUPPLY /ALIMENTADOR
 EMPOTRADO/TRANSFORMATEUR ENCASTRÉ/ EINBAU-NETZTEIL**

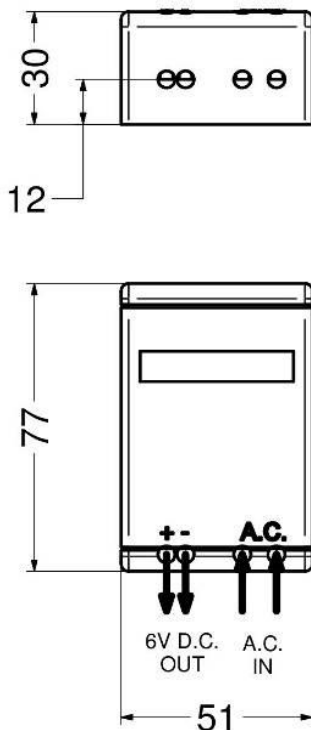

IT



COMPOSIZIONE EROGATORE DI SAPONE

- Corpo in ottone cromato
- Sensore a raggi infrarossi
- Alimentatore di rete 230V
- Pompa distributore sapone 6V
- Serbatoio sapone 2 lt.

CARATTERISTICHE FUNZIONALI

| | |
|---------------------------------|---|
| Tempo di erogazione: | 3 sec |
| Capacità serbatoio: | 2 lt |
| Alimentazione elettrica: | Alimentatore da rete 230V |
| Attivazione: | Sensore ad infrarossi a rilevamento di presenza |

EN



SOAP DISPENSER COMPOSITION

- Chromed brass body
- Infra-red sensor
- Mains transformer 230V
- Dispenser pump 6V
- Soap tank 2 lt.

OPERATING CHARACTERISTICS

| | |
|----------------------------|---|
| Flushing time: | 3 sec |
| Soap tank capacity: | 2 lt |
| Power supply: | Power by mains 230V |
| Activation: | Infra-red sensor with presence detection function |

ES



COMPOSICIÓN DOSIFICADOR DE JABÓN

- Cuerpo en latón cromado
- Sensor a infrarrojos
- Transformador eléctrico 230V
- Electroválvula biestable 6V
- Tanque de jabón 2 lt.

CARACTERÍSTICAS FUNCIONALES

| | |
|---------------------------------------|---|
| Tiempo de descarga: | 3 sec |
| capacidad del tanque de jabón: | 2 lt |
| Alimentación eléctrica: | Transformador eléctrico 230V (en dotación) |
| Activación: | Sensor a infrarrojos a detección de presencia |

FR



COMPOSITION DISTRIBUTEUR DE SAVON

- Corps en laiton chromé
- Capteur infrarouge 6V
- Transformateur électrique 230V
- Électrovanne bistable 6V
- Réservoir de savon 2 lt.

CARACTÉRISTIQUES FONCTIONNELLES

| | |
|---|--|
| Temps d'écoulement : | 3 sec |
| Capacité du réservoir de savon : | 2 lt |
| Alimentation électrique: | Transformateur électrique 230V (inclue) |
| Activation: | Capteur infrarouge à détection de présence |

DE



LIEFERUMFANG SEIFENSPENDER

- Körper aus verchromten Messing
- Infrarotsensor
- Netztransformer 230V
- Pumpe 6V
- Seifentank 2 l

FUNKTIONALE EIGENSCHAFTEN

| | |
|-----------------------------|---------------------------------------|
| Dauer: | 3 Sek. |
| Füllmenge Tank: | 2 l |
| Elektrische | Netzanschluss 230 V |
| Spannungsversorgung: | |
| Betätigung: | Infrarotsensor mit Objekterkennung |