

INSTALLATION GUIDELINES

STYLE No. LDPH05

Ludlow Shinola Edition One Arm Paper Holder with Round Escutcheon

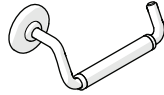

STYLE No. LDPH15

Ludlow Shinola Edition One Arm Paper Holder with Round Escutcheon and Shelf

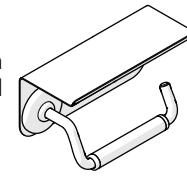

IMPORTANT:

- To ensure this product is installed properly, you must read and follow these guidelines.
- The owner/user of this product must keep this information for further reference.
- This product must be installed by a professional licensed contractor.
- Inspect this product to ensure you have all the parts required for proper installation.
- If further assistance is required, please contact Product Support at 1-800-927-2120 Monday through Friday, 8am - 6pm EST.
- Refer to the separate Service Parts Documents for available replacement parts.

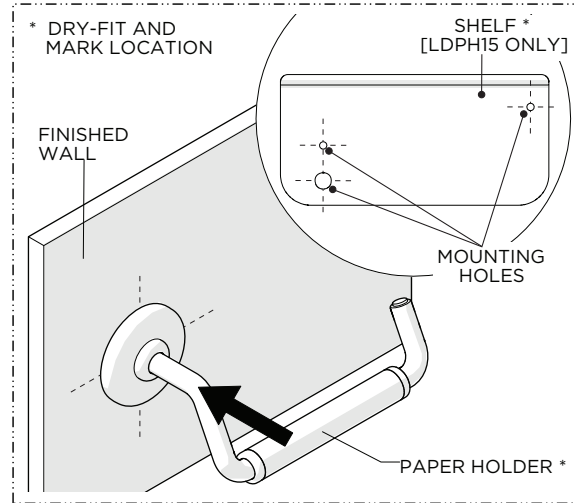

1. Dry-fit the PAPER HOLDER or SHELF to the finished wall and mark the ideal location making sure to hold the product level.

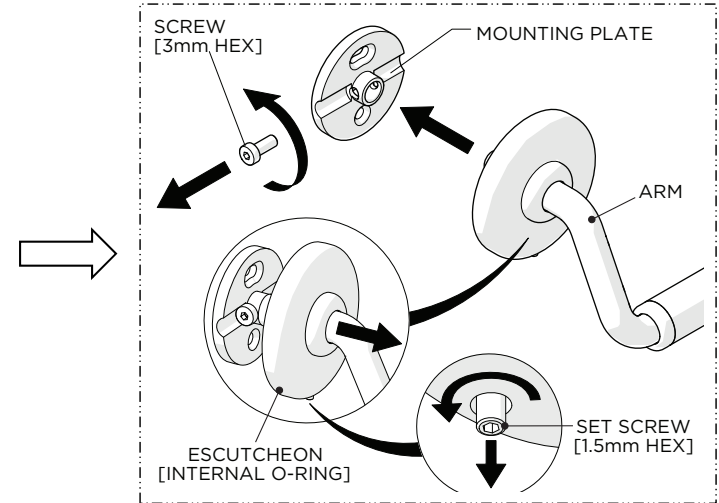

2. Loosen, but do **NOT** remove, the SET SCREW on the bottom of ESCUTCHEON and slide the ESCUTCHEON up the ARM to expose the MOUNTING PLATE then unthread the SCREW to remove the PLATE.

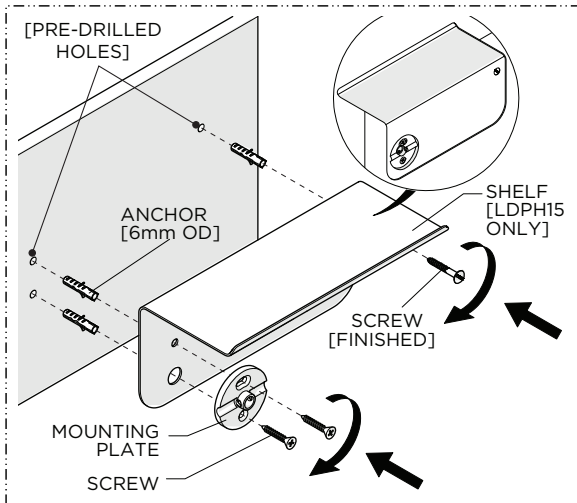

3. Using the previous marks as a reference, install the SHELF (if being used) and MOUNTING PLATES using the SCREWS and ANCHORS provided.

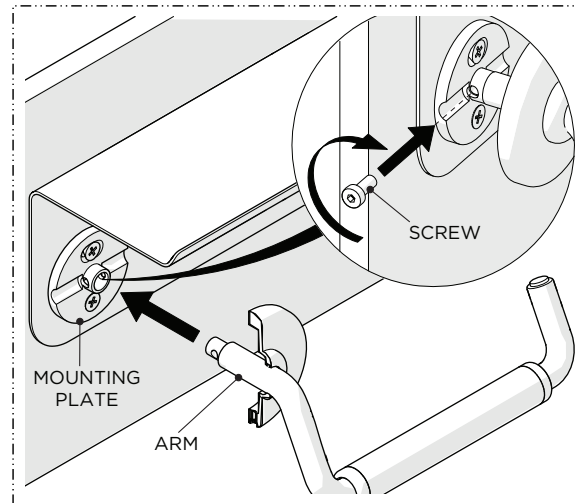

4. Insert the ARM and SCREW into the MOUNTING PLATE then thread and securely tighten the SCREW into the ARM.

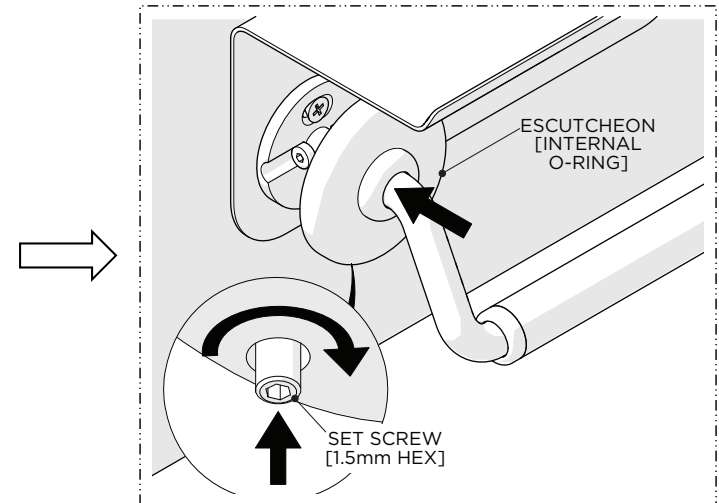

5. Slide the ESCUTCHEON down the ARM until it contact the finished wall then securely tighten the SET SCREW.

NOTE: Verify the SHELF is level and held firmly to the finished wall.