

Style No. MNLT05 [MN05LT]

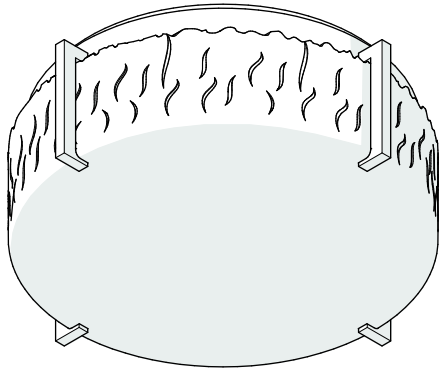

* All items in [BRACKETS] refer to UK styles

SPECIFICATIONS:

Bulb Base Size: E12 [SBC B15]

Bulb Type: Candelabra

Junction Box Orientation: Any

Junction Box Size: Standard 3-1/2"

Max Wattage: 4 Watt LED

Orientation: Ceiling Only

Shade Material: Glass

Voltage: 120 [240]

Required Electrical Feeds:

US: Black "Hot" wire; White "Neutral" wire; Green or Bare "Ground" wire

UK: [Brown "Live" wire; Blue "Neutral" wire; Green/Yellow Striped or Bare "Earth" wire]

IMPORTANT:

- **WARNING:** The power supply must be turned off prior to installation. Turn off the main electrical supply to the junction box from the fuse box/circuit breaker. Turning power off at the switch is not sufficient.
- To ensure this product is installed properly, you must read and follow these guidelines.
- The owner/user of this product must keep this information for future reference.
- MNLT05 is U.L. certified and is suitable for damp or dry locations. The U.L. listing mark can be found on the inside of the cover plate.
- MN05LT is CE rated. Proof of CE compliance will be provided upon request.
- Be sure your installation conforms to all federal, state, and local codes.
- This product must be installed by a professional licensed electrical contractor.
- Refer to the specification and assembly drawings attached. Product is sold partially assembled but shown fully disassembled for illustrative and service purposes only.

CEILING FLUSH MOUNT INSTALLATION:

- **REQUIRED:** Install a 3-1/2" octagonal electrical junction box at the desired location.

- See Figure - 01 for Steps 1 - 5.

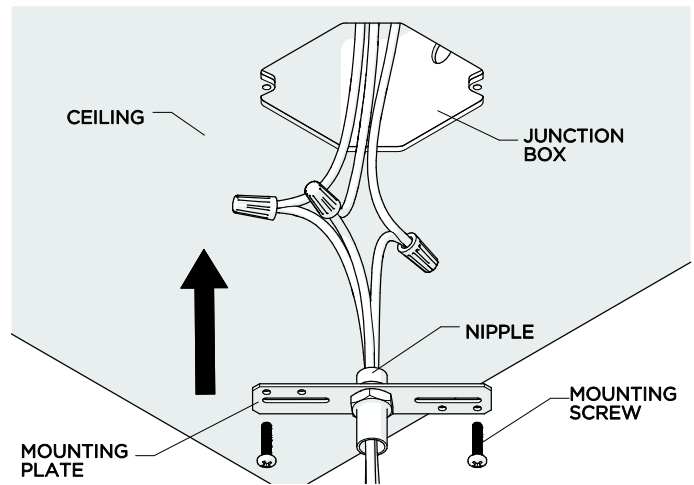

FIGURE - 01

1. Pull the wires from the light through the center of the MOUNTING PLATE.
2. Fasten the bare copper fixture wire to the green or bare copper wire in the box with a wire nut or fasten it to the MOUNTING PLATE with the ground screw provided.
3. Fasten the white fixture wire to the white wire in the box with a wire nut. Tightly wrap the connection with electrical tape beginning 1" [25mm] below the wire nut to ensure the tape seals the end of the nut. Make sure that there are no exposed wires that could cause a short circuit.
4. Repeat previous step with the black fixture wire and the black wire from the junction box. Make sure the wires are pushed into the junction box.
5. Attach the MOUNTING PLATE to the JUNCTION BOX using the MOUNTING SCREWS making sure to keep the proper alignment of the plate.

- See Figure - 02 for Step 6.

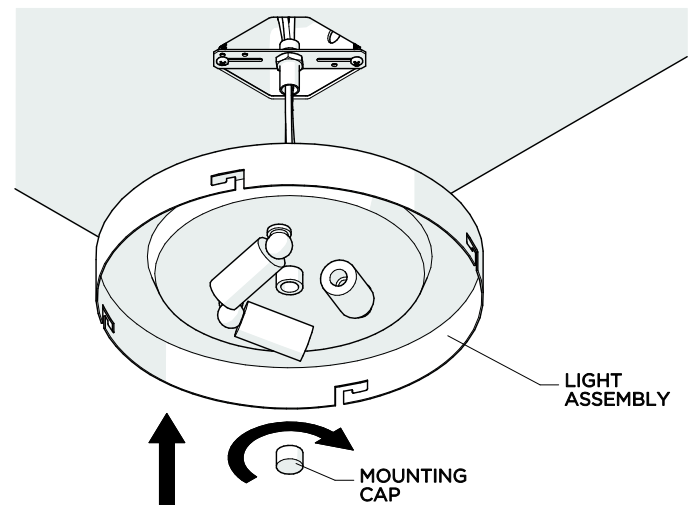

FIGURE - 02

These guidelines have been prepared for the professional contractor to aid in the installation of: MARLON CEILING FLUSH MOUNT (STYLE# MNLT05 [MN05LT]) All dimensions are based on original specification and are subject to change and variation. Please consult your Design Associate for current specifications.

WATERWORKS

6. Thread the LIGHT ASSEMBLY to the NIPPLE on the MOUNTING PLATE making sure it's secure.

➤ See Figure - 03 for Step 7.

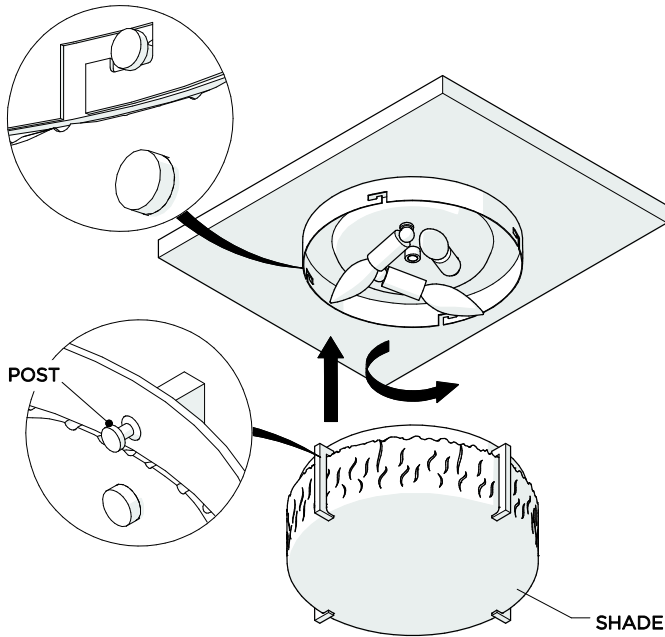

FIGURE - 03

7. Attach the SHADE by aligning the pins on the SHADE with the notches on the LIGHT ASSEMBLY and twisting counterclockwise until the SHADE is secure.

SERVICING THE LIGHT:

8. Rotate the SHADE clockwise until it is able to be lowered for cleaning and servicing.

➤ If further assistance is required, please contact Product Support at 1-800-927-2120 (8am-6pm EST).