

REF. 3.080

315-M Aparador

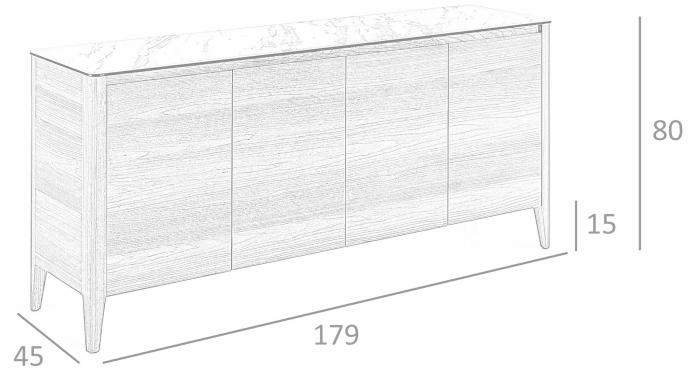

MEDIDAS

Medidas: 179 x 45 x 80 cm.

Peso: 45 Kg.

EMBALAJE

190 x 52 x 6 cm. / 12 Kg.

47 x 45 x 76 cm. / 7 Kg.

190 x 52 x 86 cm. / 32 kG

VOLUMEN

0,93 m³

PRODUCTO

Chapa Nogal

Tapa: Marmol Porcelanico Blanco

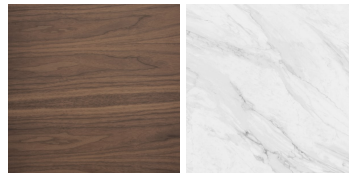

PATAS

Material Patas: Chapa Nogal

