

E0383



Collection: BRIVE

Finish*:



00 - White

Main features:



Features

- DIMENSIONS: 66 x 35.50 cm
- MATERIAL: Ceramic
- VOLUME OF WATER: Standard 3/6 L
- RIM TYPE: Open (traditional)
- SUPPLIED: Thermoset toilet seat, adjustable metal hinges E4357G; floor fixing kit

- WEIGHT: 28 kg
- INSTALLATION TYPE: Floor-standing
- HEIGHT: Standard
- RIM: With rim
- Side inlet

Consumer benefits

- SOUND COMFORT: Class 1 float valve
- MECHANISM: Water-saving 3/6 L flush

Installation benefits

- EASIER INSTALLATION: Complete factory-fitted cistern

Technical drawing

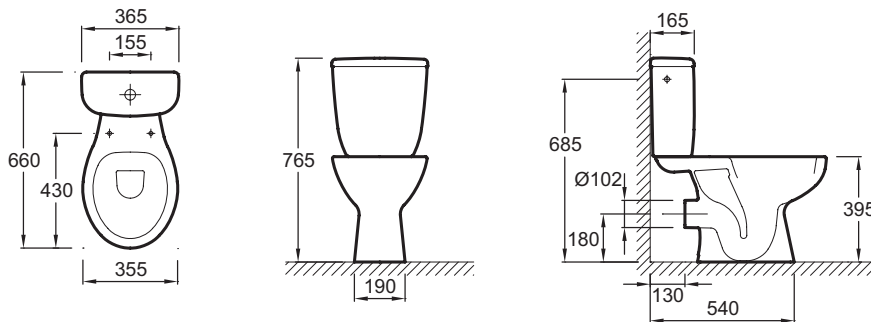

Product Specification: WC pack, P-trap, 3/6 L. E0383. Collection: BRIVE. DIMENSIONS: 66 x 35.50 cm. WEIGHT: 28 kg. MATERIAL: Ceramic. INSTALLATION TYPE: Floor-standing. VOLUME OF WATER: Standard 3/6 L. HEIGHT: Standard. RIM TYPE: Open (traditional). RIM: With rim. SUPPLIED: Thermoset toilet seat, adjustable metal hinges E4357G; floor fixing kit. Side inlet.

**Due to possible variations in computer and printer calibrations, technical factors and certain finish characteristics, the colors you see may not accurately portray the actual colors and are provided as a guide only.*