

Sink New Wave 1420 00x

Sinks

Code: 1420 00x

Code: 1420 001 DX (Vasca a destra)

Code: 1420 002 SX (Vasca a sinistra)



DETAILS

Finish Foster brushed

Material AISI 304 stainless steel

Texture Satin

Base 80 cm

Edge/Installation Type Flush-mount | Top-mount

Dimensions 1160x520 mm

Standard fittings Fixing hooks, gasket, drain, overflow and siphon, boxed packing

Mixer holes 2 standard holes

Built-in hole View technical data sheet (for all Flush-mount / Top-mount models and Under-mount models)

Drainer Yes

Width 116 cm

Bowl dimension 340x400mm

Number of bowls 2 bowls

Waste fitting Drain with automatic control SPACE

FEATURES

Automatic waste fitting The waste-fitting with round remote knob is supplied; a practical accessory which makes it unnecessary to get wet in order to drain the water from the bowl.

Diamond-shape bottom The draining of water is an important feature in a sink, and it's always taken good care of in Foster products. In the bent-welded sinks, which would have a flat bottom, the proper draining is guaranteed by the elegant beveling, which helps the water flow.

Double mixer hole The large tap counter is already fitted with a series of 2 tap holes. In the second hole it is possible to install the remote control of the automatic drain or, alternatively, a practical soap dispenser.

High thickness 1mm thick steel. A significant thickness, which guarantees the maximum sturdiness and durability.

new wave - perfect profile The wave is the exclusive feature of the New Wave sinks, a sinuous element that breaks the minimalistic rigor of square bowl and makes it more flexible - awarded with the prestigious Reddot Design Award 2015.

Perimetral overflow The overflow is always a security on the Foster sinks that prevents the overflow of water in case of oversights. The perimeter drain solution improves aesthetics thanks to its square and essential shape.

Save space system Drain and siphon are designed to leave as much space as possible in the under-sink area, more and more useful today for theseparate waste collection systems.

Space waste fitting

The elegant SPACE steel cap closes the drain and leaves no visible residues collected in the basket below. Space also has a small footprint and allows the optimal use of the under-sink compartment.

Squared bowls - 0/9 radius

The square bowls of Foster have perfectly squared vertical edges, while those on the bottom have a small radius of 9 mm that facilitates cleaning operations.

TECHNICAL DATA

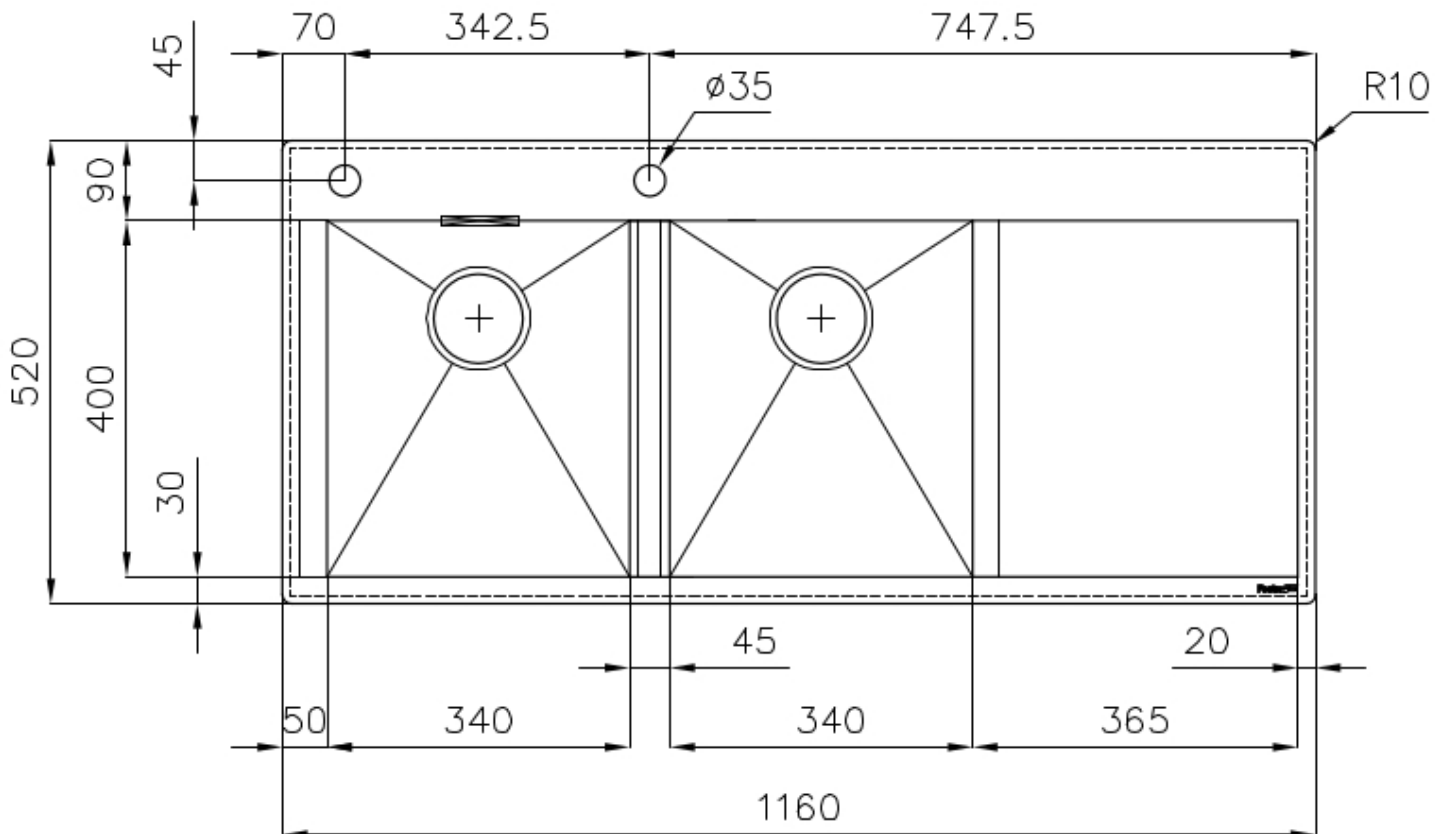
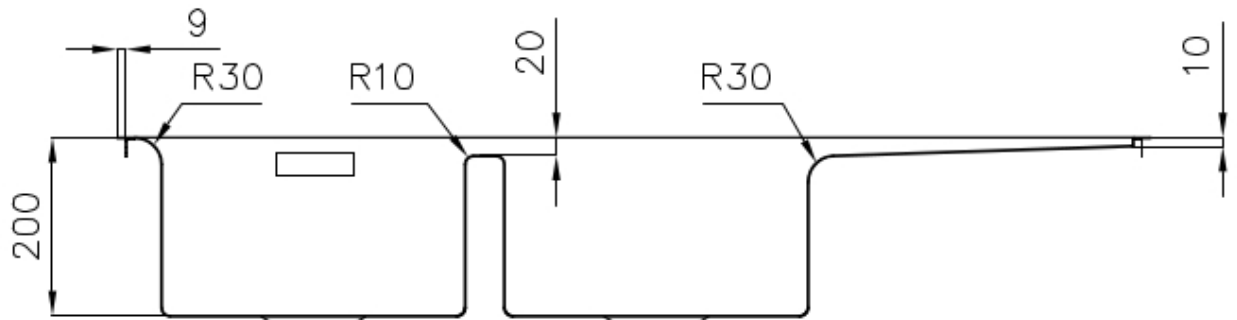

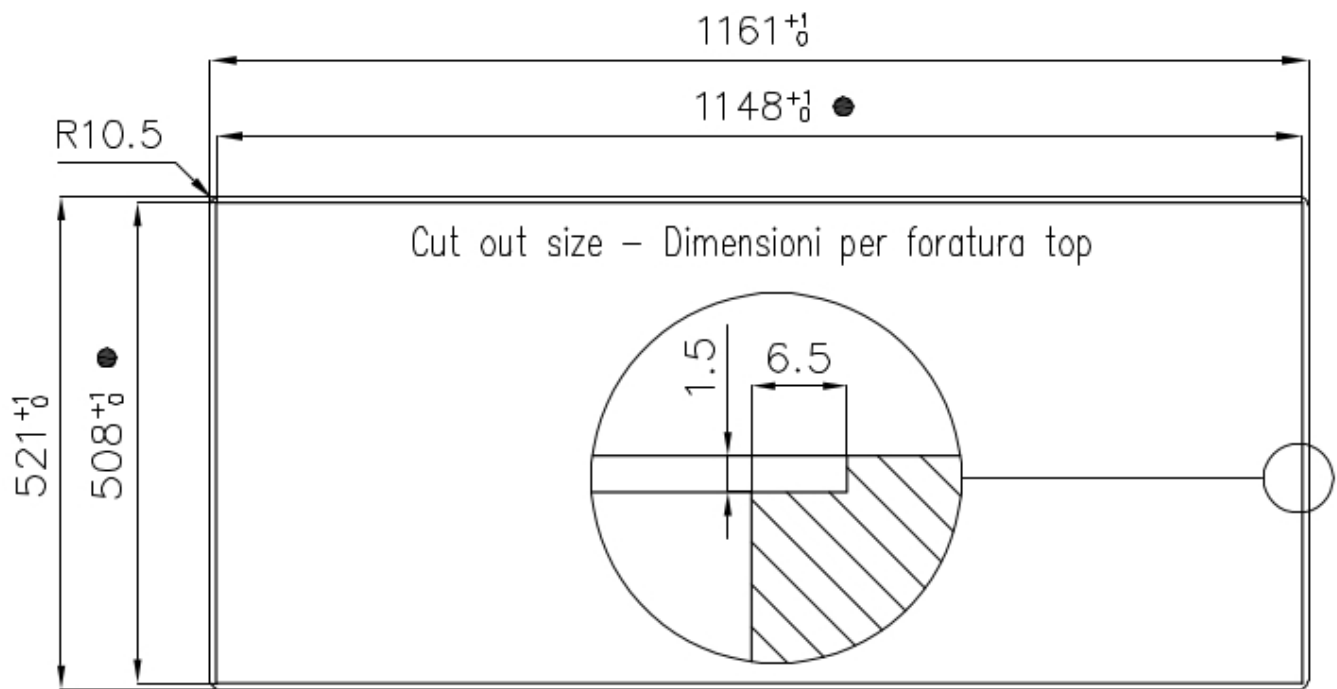

- Built-in cut out for FTS – Foratura per installazione FTS

GALLERY



EQUIPMENT



Space automatic waste fitting
8407 108

OPTIONAL ACCESSORIES



HPDE Chopping board 8657 001



HPDE Twin chopping board 8644 101

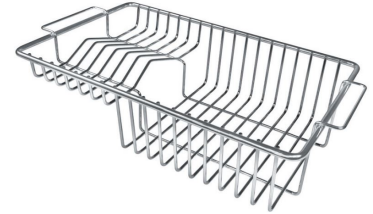

Stainless steel plate rack 8100 201

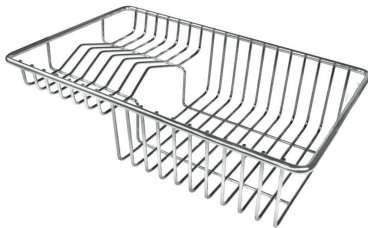

Stainless steel plate rack 8100 303



White bowl 8153 100



Glass chopping board 8631 300



Graters kit with ring-holder and food collection tray 8159 101



Stainless steel perforated tray 8151 000

WARNING:

The accessories 8159101, 8100303,8151000 are only usable in combination with 8644101

RECOMMENDED PAIRINGS



Mixer Tap 1/2 Circle 8480 000



Mixer Tap Play 8487 000