

Cooker hob S4000 Line XL 7284 042

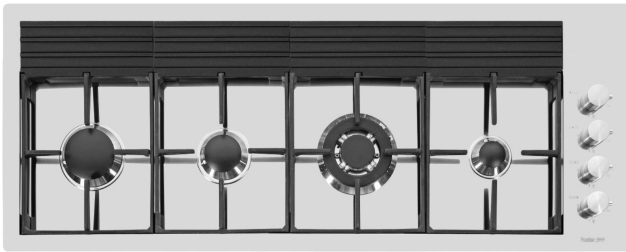

Cooker hobs

Code: 7284 042



DETAILS

Finish Foster brushed

Material AISI 304 stainless steel

Texture Satin

Supply 220-240 V; 50.60 Hz

Edge/Installation Type Flush-mount | Top-mount

Dimensions 1179x465 mm

Base size 118cm

Heating element Four burners

Built-in hole View technical data sheet (for all Flush-mount / Top-mount models and Under-mount models)

Grids Cast iron grids and enamelled burner covers

Total power 9.650 W

Auxiliary 1.100 W

Semirapid 1.750 W

Rapid 3.000 W

Triple crown 3.800 W

Safety Safety valve with quick-acting thermocouple

Ignition Electric ignition under knob

Gas type Tested for installation with natural gas, LPG nozzle set included.

Type Gas Hob

EQUIPMENT

4 x Cast iron pot support 9601
741
1 x Cast iron wok support 9601
668

FEATURES

Cast iron grids

Cast-iron is the ideal material for an hob grid, this due to the manifold properties characterising it: high heat capacity that improves cooking performance; high weight and stability that improve safety; sturdiness that preserves the hob's original aspect over time; easy cleaning.

lil series burners

lil series burners: 20% gas savings. They guarantee an efficiency well above the European standards. Furthermore, the improved combustion of gas allows the development of higher powers. From the point of view of safety, the blocking system between the cover and the flame-spreader guarantees perfect positioning and greater ease of cleaning.

Safe cooking

All Foster cooker hobs are equipped with safety valves. They shut off the gas supply very quickly if the flame accidentally goes out.

Special burners

Many Foster hobs are equipped with special burners, with two or three rings of fire that greatly increase the power delivered and the heated surface. In the DUAL models the two fire crowns also have independent ignition, making these burners perfect for both intensive and delicate cooking.

Ultra-flat hob

Design meets functionality in the the ultra-flat models. Elegant grids that form a generously sized overall surface.

Under-knob ignition

The utmost freedom of movement with electronic under-knob ignition, a common feature of all models that allows a one-hand ignition of the burner.

TECHNICAL DATA

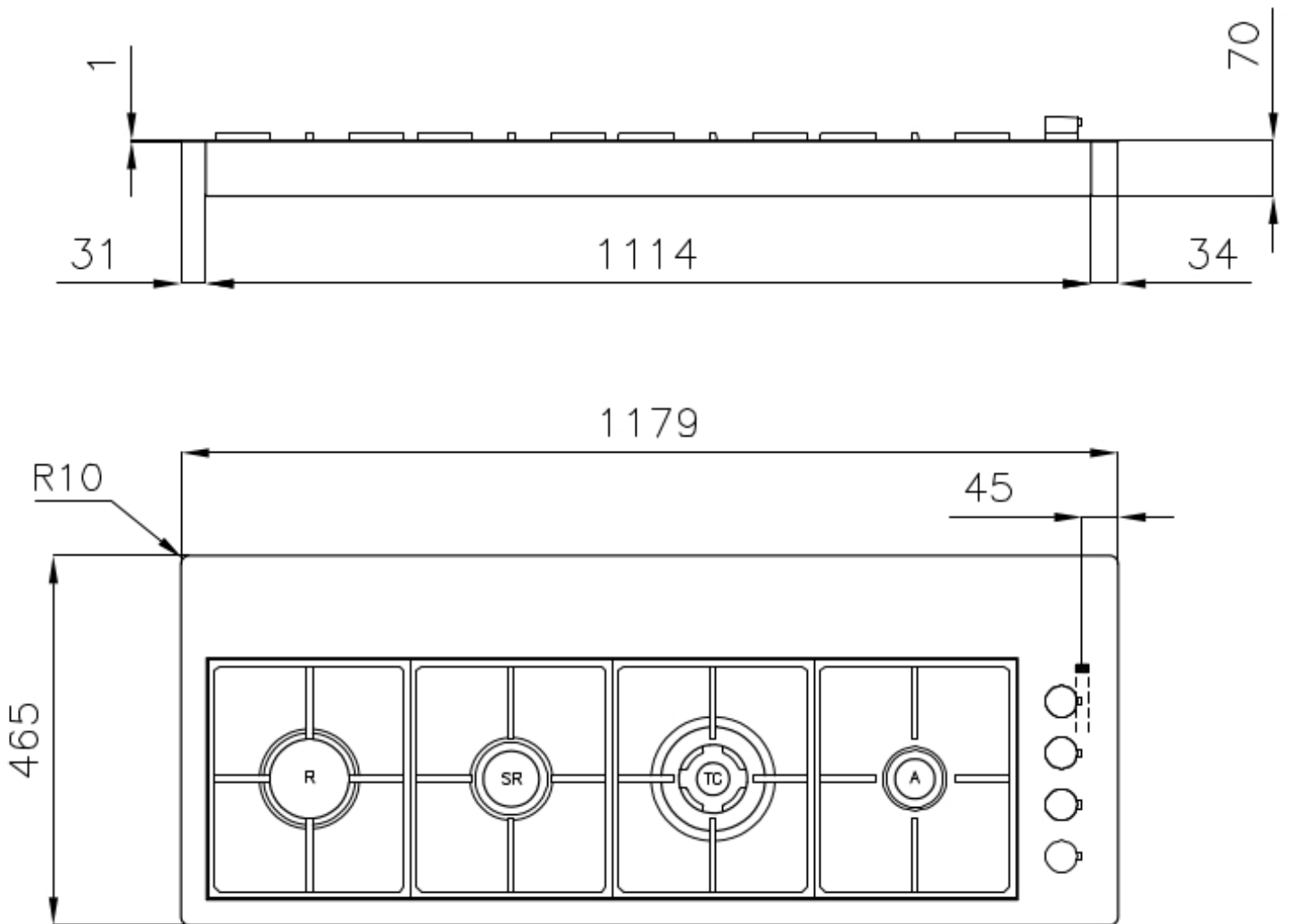

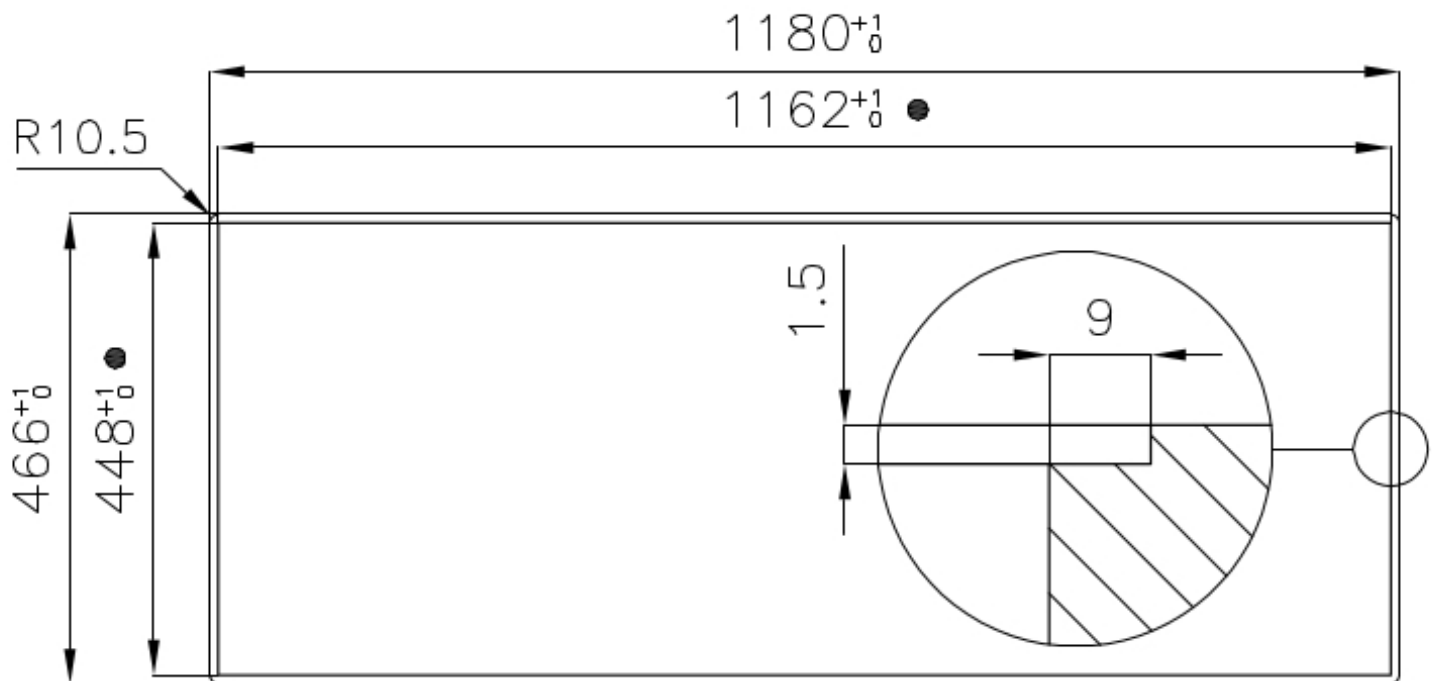

- Built-in cut out for FTS – Foratura per installazione FTS

GALLERY



EQUIPMENT



Cast iron pot support 9601 741



Cast iron wok support 9601 668

RECOMMENDED PAIRINGS



Hood Ghost 120 Filotop 2451 120



Sink Quadra 1218 050