

FOAM SOAP DISPENSER WP173-5 FOR MOUNTING IN CABINET



67 x 247 x 115 mm

400 ml foam soap concentrate

- Foam soap dispenser in robust, germ-reducing and easy-care stainless steel (AISI 316L).
- For mounting in cabinet on site.
- One-hand operated and non-drip foam soap pump.
- Designed for standard 400 ml foam soap concentrate. Refillable from the top.
- Wear parts can be replaced as modules.
- Mounting: With two screws through key holes and one optional anti-theft hole in the back wall.
- Delivery includes fixing material, self-adhesive information label „Soap“ and first fill with foam soap concentrate.
- Weight, including single package: 1.0 kg



Suggested text for specifications:

Foam soap dispenser in stainless steel (AISI 316L) for mounting in cabinet. One-hand operated and non-drip foam soap pump. Designed for standard 400 ml foam soap concentrate. Refillable from the top. Delivery includes fixing material, self-adhesive information label „Soap“ and first fill with foam soap concentrate.

Dimensions: 67 x 247 x 115 mm

Article No. WP173-5

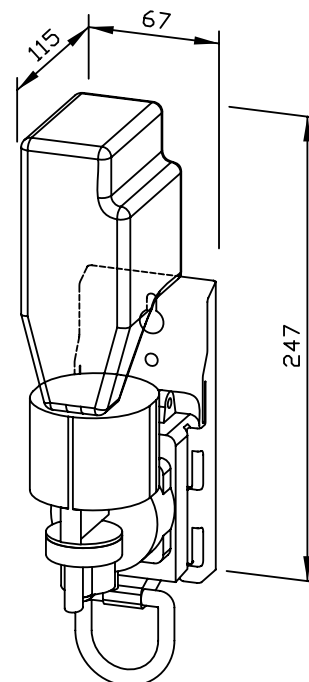

Available surface	ID No.
satin finished	727 185

Ernst Wagner GmbH & Co. KG

Ernst-Abbe-Straße 21 · D-72770 Reutlingen · Tel.: +49712151539-0 · Fax: -20
info@wagner-ewar.de · www.wagner-ewar.de

WAGNER
EWAR