

Marchio / Brand ZUCCHETTI

Classe / Class WW

## AGUABLU

ZA5699

Batteria lavabo incasso a tre fori. / 3 hole built-in basin mixer.



Batteria lavabo incasso a tre fori.

3 hole built-in basin mixer.

R99500

Parte incasso corpo unico, interasse 200 mm /  
Assembled built-in part, interaxe 200 mm.



R99504

Parte incasso con elementi liberi, distanza  
variabile / Built-in part, not assembled,  
variable distance.



## Finiture / Finishes



Cromo / Chrome

## AGUABLU

ZA5699

Disegno Complessivo / Overall Drawing

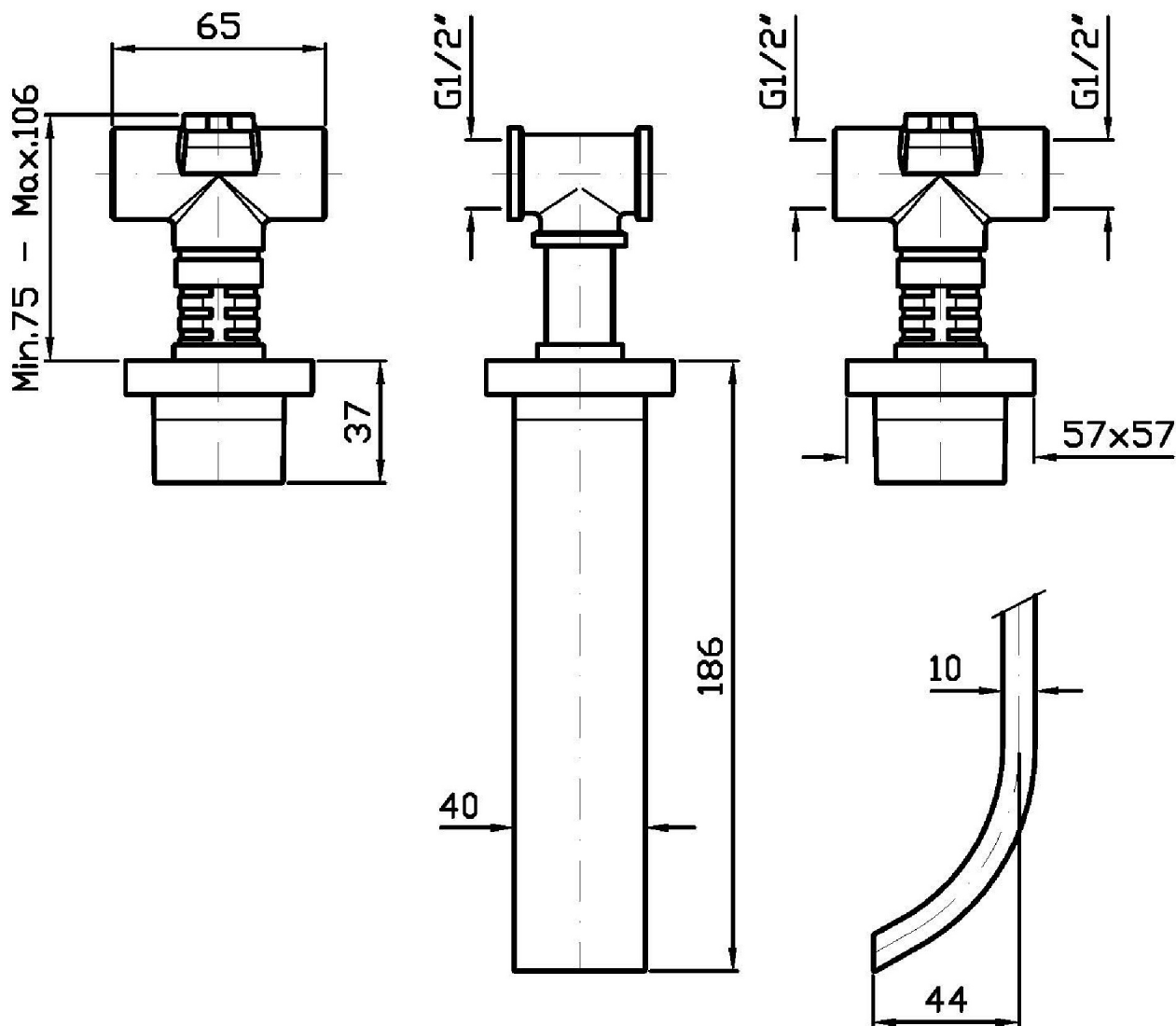

## AGUABLU

ZA5699

Esplosi / Exploded

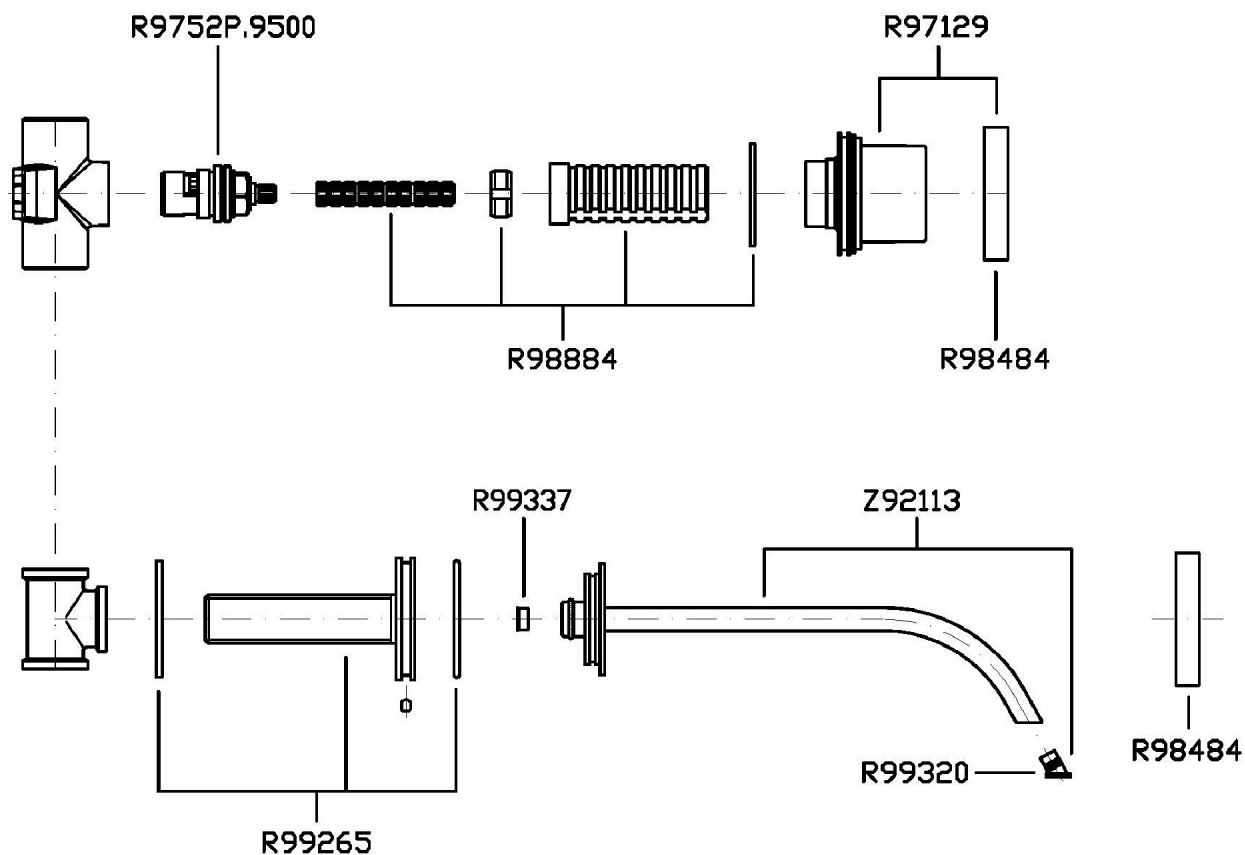

## AGUABLU

ZA5699 Portate / Flowrates (lt/min)

PRESSIONE PRESSURE	1 BAR	2 BAR	3 BAR	4 BAR	5 BAR
P1 LAVABO BASIN	7,1	10,3	12,6	14,5	16,3
P2					
P3					
P4					
P5					

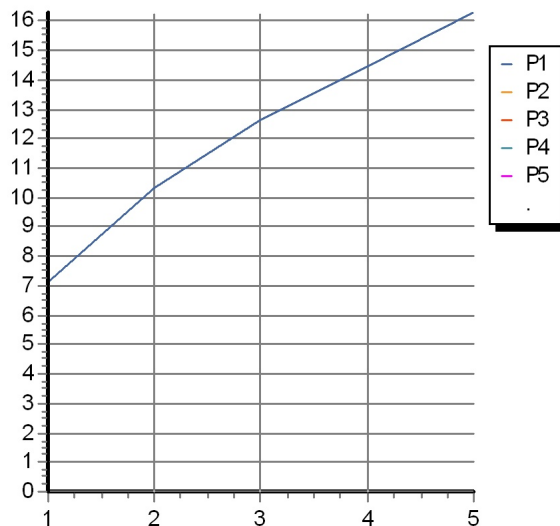

## AGUABLU

ZA5699 Pesì e Misure / Weights and Sizes

Peso ( Kg ) Weight ( lb )	1,88 ( Kg )	4,14 ( lb )
Volume test ( dc3 ) - ( in3 )	7,43 ( dc3 )	453,41 ( in3 )
h ( mm ) - ( in )	90,00 ( mm )	3,54 ( in )
L1 ( mm ) - ( in )	250,00 ( mm )	9,84 ( in )
L2 ( mm ) - ( in )	330,00 ( mm )	12,99 ( in )

