

**E75385**



**Collection:** MODULO

**Finish\*:**



CP - Chrome

**Main features:**



**Features**

- **DIMENSIONS:** 23 x 19.10 x 15 cm
- **MATERIAL:** Metal
- Operates with all types of water heaters, minimum capacity 18 kW

- **WEIGHT:** 3 kg
- **INSTALLATION TYPE:** Wall-mount

**Consumer benefits**

- **SAFETY:** Push-in stop at 38°C. Maximum temperature 50°C
- **ERGONOMICS:** Ergonomic handles and blue/red marks
- **FINISH:** Chrome - 10-year warranty
- **MECHANISM:** 5-year warranty

**Installation benefits**

- Operates with any water heater of at least 18 kW

**Required products**

- 98699D: Universal recessed box

**Technical drawing**

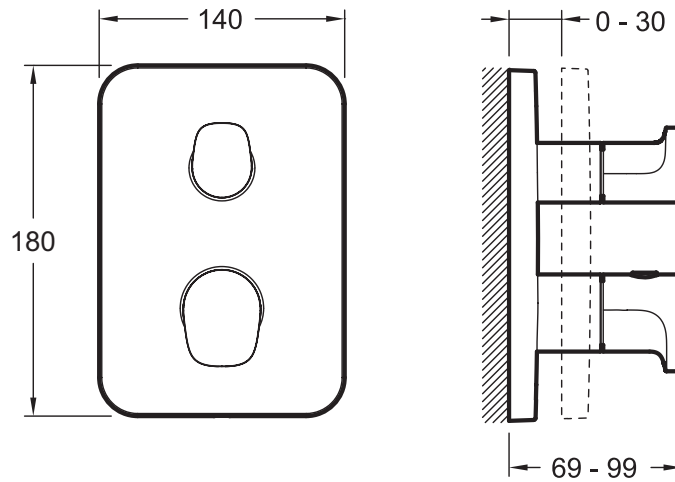

Product Specification: Thermostatic mixer with stop valve - Hybrid handles. E75385. Collection: MODULO. DIMENSIONS: 23 x 19.10 x 15 cm. WEIGHT: 3 kg. MATERIAL: Metal. INSTALLATION TYPE: Wall-mount. Operates with all types of water heaters, minimum capacity 18 kW.

*\*Due to possible variations in computer and printer calibrations, technical factors and certain finish characteristics, the colors you see may not accurately portray the actual colors and are provided as a guide only.*