

Modular Safety Controller

Communication Guide

10/2020



E100000004014.00

www.schneider-electric.com

Schneider
Electric

The information provided in this documentation contains general descriptions and/or technical characteristics of the performance of the products contained herein. This documentation is not intended as a substitute for and is not to be used for determining suitability or reliability of these products for specific user applications. It is the duty of any such user or integrator to perform the appropriate and complete risk analysis, evaluation and testing of the products with respect to the relevant specific application or use thereof. Neither Schneider Electric nor any of its affiliates or subsidiaries shall be responsible or liable for misuse of the information contained herein. If you have any suggestions for improvements or amendments or have found errors in this publication, please notify us.

You agree not to reproduce, other than for your own personal, noncommercial use, all or part of this document on any medium whatsoever without permission of Schneider Electric, given in writing. You also agree not to establish any hypertext links to this document or its content. Schneider Electric does not grant any right or license for the personal and noncommercial use of the document or its content, except for a non-exclusive license to consult it on an "as is" basis, at your own risk. All other rights are reserved.

All pertinent state, regional, and local safety regulations must be observed when installing and using this product. For reasons of safety and to help ensure compliance with documented system data, only the manufacturer should perform repairs to components.

When devices are used for applications with technical safety requirements, the relevant instructions must be followed.

Failure to use Schneider Electric software or approved software with our hardware products may result in injury, harm, or improper operating results.

Failure to observe this information can result in injury or equipment damage.

© 2020 Schneider Electric. All rights reserved.

Table of Contents



	Safety Information	5
	About the Book	9
Part I	Component-Specific Hardware Information	15
Chapter 1	Technical Features	17
1.1	XPSMCMx Fieldbus Expansion Modules	18
	Modules and Functional Description	19
	Connector Designations and Example Wiring Diagram	20
	LED Indicators	21
	Data Provided via Fieldbus	23
1.2	Module Characteristics	31
	General Module Characteristics	32
	XPSMCMCO0000CO• CANopen	33
	XPSMCMCO0000CO• CANopen - Mapping Information	35
	XPSMCMCO0000EC• EtherCAT	46
	XPSMCMCO0000EC• EtherCAT - Mapping Information	48
	XPSMCMCO0000EI• EtherNet/IP	57
	XPSMCMCO0000EI• EtherNet/IP - Mapping Information	59
	XPSMCMCO0000MB• Modbus	65
	XPSMCMCO0000MB• Modbus RTU - Mapping Information	67
	XPSMCMCO0000EM• Modbus TCP	75
	XPSMCMCO0000EM• Modbus TCP - Mapping Information	77
	XPSMCMCO0000PB• Profibus	84
	XPSMCMCO0000PB• Profibus - Mapping Information	86
Part II	SoSafe Configurable	97
Chapter 2	BUS Configurator Software	99
	Bus Configurator Overview	100
	Connection, Configuration and Monitoring/Diagnostics	103
	Examples	110
	Configuration Example in SoSafe Configurable and Representation in BUS Configurator	117
	XPSMCMCO0000• Fieldbus Modules Compatibility Chart	120
Index	121

Safety Information



Important Information

NOTICE

Read these instructions carefully, and look at the equipment to become familiar with the device before trying to install, operate, service, or maintain it. The following special messages may appear throughout this documentation or on the equipment to warn of potential hazards or to call attention to information that clarifies or simplifies a procedure.



The addition of this symbol to a “Danger” or “Warning” safety label indicates that an electrical hazard exists which will result in personal injury if the instructions are not followed.



This is the safety alert symbol. It is used to alert you to potential personal injury hazards. Obey all safety messages that follow this symbol to avoid possible injury or death.

DANGER

DANGER indicates a hazardous situation which, if not avoided, **will result in** death or serious injury.

WARNING

WARNING indicates a hazardous situation which, if not avoided, **could result in** death or serious injury.

CAUTION

CAUTION indicates a hazardous situation which, if not avoided, **could result** in minor or moderate injury.

NOTICE

NOTICE is used to address practices not related to physical injury.

PLEASE NOTE

Electrical equipment should be installed, operated, serviced, and maintained only by qualified personnel. No responsibility is assumed by Schneider Electric for any consequences arising out of the use of this material.

A qualified person is one who has skills and knowledge related to the construction and operation of electrical equipment and its installation, and has received safety training to recognize and avoid the hazards involved.

BEFORE YOU BEGIN

Do not use this product on machinery lacking effective point-of-operation guarding. Lack of effective point-of-operation guarding on a machine can result in serious injury to the operator of that machine.

 WARNING
UNGUARDED EQUIPMENT
<ul style="list-style-type: none">• Do not use this software and related automation equipment on equipment which does not have point-of-operation protection.• Do not reach into machinery during operation.
Failure to follow these instructions can result in death, serious injury, or equipment damage.

This automation equipment and related software is used to control a variety of industrial processes. The type or model of automation equipment suitable for each application will vary depending on factors such as the control function required, degree of protection required, production methods, unusual conditions, government regulations, etc. In some applications, more than one processor may be required, as when backup redundancy is needed.

Only you, the user, machine builder or system integrator can be aware of all the conditions and factors present during setup, operation, and maintenance of the machine and, therefore, can determine the automation equipment and the related safeties and interlocks which can be properly used. When selecting automation and control equipment and related software for a particular application, you should refer to the applicable local and national standards and regulations. The National Safety Council's Accident Prevention Manual (nationally recognized in the United States of America) also provides much useful information.

In some applications, such as packaging machinery, additional operator protection such as point-of-operation guarding must be provided. This is necessary if the operator's hands and other parts of the body are free to enter the pinch points or other hazardous areas and serious injury can occur. Software products alone cannot protect an operator from injury. For this reason the software cannot be substituted for or take the place of point-of-operation protection.

Ensure that appropriate safeties and mechanical/electrical interlocks related to point-of-operation protection have been installed and are operational before placing the equipment into service. All interlocks and safeties related to point-of-operation protection must be coordinated with the related automation equipment and software programming.

NOTE: Coordination of safeties and mechanical/electrical interlocks for point-of-operation protection is outside the scope of the Function Block Library, System User Guide, or other implementation referenced in this documentation.

START-UP AND TEST

Before using electrical control and automation equipment for regular operation after installation, the system should be given a start-up test by qualified personnel to verify correct operation of the equipment. It is important that arrangements for such a check be made and that enough time is allowed to perform complete and satisfactory testing.

WARNING

EQUIPMENT OPERATION HAZARD

- Verify that all installation and set up procedures have been completed.
- Before operational tests are performed, remove all blocks or other temporary holding means used for shipment from all component devices.
- Remove tools, meters, and debris from equipment.

Failure to follow these instructions can result in death, serious injury, or equipment damage.

Follow all start-up tests recommended in the equipment documentation. Store all equipment documentation for future references.

Software testing must be done in both simulated and real environments.

Verify that the completed system is free from all short circuits and temporary grounds that are not installed according to local regulations (according to the National Electrical Code in the U.S.A, for instance). If high-potential voltage testing is necessary, follow recommendations in equipment documentation to prevent accidental equipment damage.

Before energizing equipment:

- Remove tools, meters, and debris from equipment.
- Close the equipment enclosure door.
- Remove all temporary grounds from incoming power lines.
- Perform all start-up tests recommended by the manufacturer.

OPERATION AND ADJUSTMENTS

The following precautions are from the NEMA Standards Publication ICS 7.1-1995 (English version prevails):

- Regardless of the care exercised in the design and manufacture of equipment or in the selection and ratings of components, there are hazards that can be encountered if such equipment is improperly operated.
- It is sometimes possible to misadjust the equipment and thus produce unsatisfactory or unsafe operation. Always use the manufacturer's instructions as a guide for functional adjustments. Personnel who have access to these adjustments should be familiar with the equipment manufacturer's instructions and the machinery used with the electrical equipment.
- Only those operational adjustments actually required by the operator should be accessible to the operator. Access to other controls should be restricted to prevent unauthorized changes in operating characteristics.

About the Book



At a Glance

Document Scope

The present communication guide describes the fieldbus modules of the XPSMCM• Modular Safety Controller system, the operation of the fieldbus modules via a range of different fieldbuses, and the use of the BUS Configurator software.

The XPSMCM• Modular Safety Controller system consists of controller units XPSMCMCP0802• or XPSMCMC10804•, which can be configured using the SoSafe Configurable software. Fieldbus modules can be connected to the XPSMCMCP0802• Modular Safety Controller or XPSMCMC10804• Modular Safety Controller and configured using the BUS Configurator software.

Validity Note

This document has been updated for the release of BUS Configurator V4.2.2.

The technical characteristics of the devices described in the present document also appear online. To access the information online, go to the Schneider Electric home page www.se.com.

The characteristics that are described in the present document should be the same as those characteristics that appear online. In line with our policy of constant improvement, we may revise content over time to improve clarity and accuracy. If you see a difference between the document and online information, use the online information as your reference.

Related Documents

Document title	Reference
Modular Safety Controller Hardware Guide	EIO000004000 (ENG); EIO000004001 (FRE); EIO000004002 (GER); EIO000004003 (ITA); EIO000004004 (SPA); EIO000004005 (CHS) EIO000004006 (POR)
Modular Safety Controller Library and Programming Guide	EIO000004007 (ENG); EIO000004008 (FRE); EIO000004009 (GER); EIO000004010 (ITA); EIO000004011 (SPA); EIO000004012 (CHS) EIO000004013 (POR)

Product Related Information

The XPSMCM• can reach a maximum Safety Integrity Level (SIL) 3 as per IEC 61508, a maximum Safety Integrity Level Claim Limit (SILcl) as per IEC 62061, and a maximum Performance Level (PL) e, category 4, as per ISO 13849-1. However, the definitive SIL and PL of the application depends on a number of safety-related components, their parameters, and the connections that are made, as per the risk analysis.

The module must be configured in accordance with the application-specific risk analysis and all the applicable standards.

Pay particular attention in conforming to any safety information, different electrical requirements, and normative standards that would apply to your adaptation.

WARNING

INSUFFICIENT SAFETY-RELATED FUNCTIONS

- Perform a risk assessment as per ISO 12100 and/or other equivalent assessment and appropriately consider all applicable regulations and standards that apply to your machine/process before using this software.
- In your risk assessment, determine all requirements regarding the Safety Integrity Level (SIL), the Performance Level (PL), and any other safety-related requirements and capabilities applicable to your machine/process.

Failure to follow these instructions can result in death, serious injury, or equipment damage.

NOTE: Configuration of the module is the sole responsibility of the installer or user.

WARNING

UNAUTHENTICATED ACCESS AND SUBSEQUENT UNAUTHORIZED MACHINE OPERATION

- Evaluate whether your environment or your machines are connected to your critical infrastructure and, if so, take appropriate steps in terms of prevention, based on Defense-in-Depth, before connecting the automation system to any network.
- Limit the number of devices connected to a network to the minimum necessary.
- Isolate your industrial network from other networks inside your company.
- Protect any network against unintended access by using firewalls, VPN, or other, proven security measures.
- Monitor activities within your systems.
- Prevent subject devices from direct access or direct link by unauthorized parties or unauthenticated actions.
- Prepare a recovery plan including backup of your system and process information.

Failure to follow these instructions can result in death, serious injury, or equipment damage.

For more information on organizational measures and rules covering access to infrastructures, refer to ISO/IEC 27000 series, Common Criteria for Information Technology Security Evaluation, ISO/IEC 15408, IEC 62351, ISA/IEC 62443, NIST Cybersecurity Framework, Information Security Forum - Standard of Good Practice for Information Security.

Terminology Derived from Standards

The technical terms, terminology, symbols and the corresponding descriptions in this manual, or that appear in or on the products themselves, are generally derived from the terms or definitions of international standards.

In the area of functional safety systems, drives and general automation, this may include, but is not limited to, terms such as *safety*, *safety function*, *safe state*, *fault*, *fault reset*, *malfunction*, *failure*, *error*, *error message*, *dangerous*, etc.

Among others, these standards include:

Standard	Description
IEC 61131-2:2007	Programmable controllers, part 2: Equipment requirements and tests.
ISO 13849-1:2015	Safety of machinery: Safety related parts of control systems. General principles for design.
EN 61496-1:2013	Safety of machinery: Electro-sensitive protective equipment. Part 1: General requirements and tests.
ISO 12100:2010	Safety of machinery - General principles for design - Risk assessment and risk reduction
EN 60204-1:2006	Safety of machinery - Electrical equipment of machines - Part 1: General requirements
ISO 14119:2013	Safety of machinery - Interlocking devices associated with guards - Principles for design and selection
ISO 13850:2015	Safety of machinery - Emergency stop - Principles for design
IEC 62061:2015	Safety of machinery - Functional safety of safety-related electrical, electronic, and electronic programmable control systems
IEC 61508-1:2010	Functional safety of electrical/electronic/programmable electronic safety-related systems: General requirements.
IEC 61508-2:2010	Functional safety of electrical/electronic/programmable electronic safety-related systems: Requirements for electrical/electronic/programmable electronic safety-related systems.
IEC 61508-3:2010	Functional safety of electrical/electronic/programmable electronic safety-related systems: Software requirements.
IEC 61784-3:2016	Industrial communication networks - Profiles - Part 3: Functional safety fieldbuses - General rules and profile definitions.
2006/42/EC	Machinery Directive
2014/30/EU	Electromagnetic Compatibility Directive
2014/35/EU	Low Voltage Directive

In addition, terms used in the present document may tangentially be used as they are derived from other standards such as:

Standard	Description
IEC 60034 series	Rotating electrical machines
IEC 61800 series	Adjustable speed electrical power drive systems
IEC 61158 series	Digital data communications for measurement and control – Fieldbus for use in industrial control systems

Finally, the term *zone of operation* may be used in conjunction with the description of specific hazards, and is defined as it is for a *hazard zone* or *danger zone* in the *Machinery Directive (2006/42/EC)* and *ISO 12100:2010*.

NOTE: The aforementioned standards may or may not apply to the specific products cited in the present documentation. For more information concerning the individual standards applicable to the products described herein, see the characteristics tables for those product references.

Standards Relating to the Modular Safety Controller

The following list provides an overview of the standards that relate to the Modular Safety Controller:

Standard	Description
ISO 13849-1:2015	Safety of machinery - Safety-related parts of control systems - Part 1: General principles for design
ISO 13855:2010	Safety of machinery - Positioning of safeguards with respect to the approach speeds of parts of the human body
IEC 61131-2	Industrial-process measurement and control - Programmable controllers – Part 2: Equipment requirements and tests
EN 61496-1:2013	Safety of machinery - Electro-sensitive protective equipment - Part 1: General requirements and tests
IEC 61508-1:2010	Functional safety of electrical/electronic/programmable electronic safety-related systems - Part 1: General requirements
IEC 61508-2:2010	Functional safety of electrical/electronic/programmable electronic safety-related systems - Part 2: Requirements for electrical/electronic/programmable electronic safety-related systems
IEC 61508-3:2010	Functional safety of electrical/electronic/programmable electronic safety-related systems - Part 3: Software requirements
IEC 61508-4:2010	Functional safety of electrical/electronic/programmable electronic safety-related systems- Part 4: Definitions and abbreviations
IEC 61800-5-2:2016	Adjustable speed electrical power drive systems - Part 5-2: Safety requirements – Functional
2014/65/EU	Restriction of the use of certain hazardous substances in Electrical and Electronic Equipment

The list of standards relating to the modular safety controller is not intended to be exhaustive relative to your specific application. Further, there may be additional functional safety standards that may apply to your particular application. Consult the User Guides of the Modular Safety Controller and visit the Schneider Electric website at www.se.com for product certifications which detail compliance with specific standards, regulations, and directives.

Part I

Component-Specific Hardware Information

Chapter 1

Technical Features

What Is in This Chapter?

This chapter contains the following sections:

Section	Topic	Page
1.1	XPSMCMx Fieldbus Expansion Modules	18
1.2	Module Characteristics	31

Section 1.1

XPSMCMx Fieldbus Expansion Modules

What Is in This Section?

This section contains the following topics:

Topic	Page
Modules and Functional Description	19
Connector Designations and Example Wiring Diagram	20
LED Indicators	21
Data Provided via Fieldbus	23

Modules and Functional Description

Presentation

The XPSMCMCO0000CO•, XPSMCMCO0000EC•, XPSMCMCO0000EI•, XPSMCMCO0000MB•, XPSMCMCO0000EM•, and XPSMCMCO0000PB• are fieldbus expansion modules for the XPSMCM• Modular Safety Controller system offer. The fieldbus expansion modules can only be used in conjunction with the XPSMCMCP0802• or the XPSMCMC10804• Modular Safety Controller.

The fieldbus modules allow the Modular Safety Controller to be integrated into a fieldbus and transmit status and diagnostics data to other equipment on the fieldbus and to receive data on the status of the fieldbus from such equipment.

The fieldbus expansion modules can be configured using the BUS Configurator software (*see page 100*), part of the install package for SoSafe Configurable software.

One fieldbus expansion module can be added to your Modular Safety Controller system via backplane expansion (*see Modular Safety Controller, Hardware Guide*).

The following fieldbus expansion modules are available:

Module reference	Interface	Type (short name in software and on product)
XPSMCMCO0000CO•	CANopen	CAN
XPSMCMCO0000EC•	EtherCAT	ECT
XPSMCMCO0000EI•	EtherNet/IP	EIP
XPSMCMCO0000MB•	Modbus Serial	MBS
XPSMCMCO0000EM•	Modbus TCP/IP	MTP
XPSMCMCO0000PB•	Profibus DP	PDP

Connector Designations and Example Wiring Diagram

Fieldbus Expansion Modules Connector Designations

CAN , ECT, EIP, MBS, MTP, PDP

Terminal	Signal	LED	Description
1	24 VDC	PWR	24 Vdc power supply
2	-	-	Not connected
3			
4	0 VDC	PWR	0 Vdc power supply
5	-	-	Not connected
6			
7			
8			

Fieldbus Expansion Modules Example Wiring Diagram

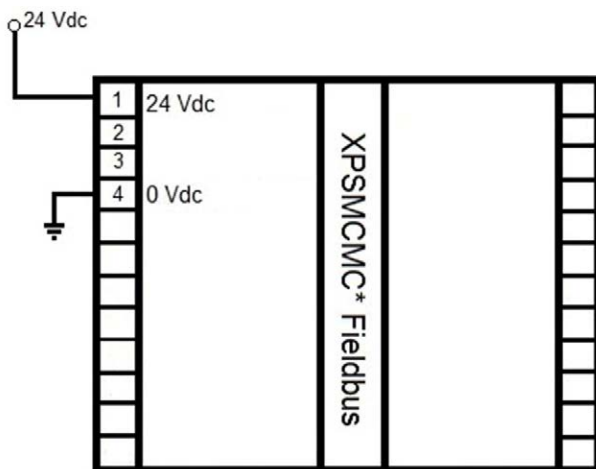

NOTE: Best practice dictates the use of fusing on the incoming 24 Vdc power, and sized appropriately for the requirements of the module.

LED Indicators

Front-Face View



Common LEDs for Operation

The following table describes the states of the common LED indicators of the fieldbus expansion modules:

PWR green	RUN green	E IN red	E EX red	First module- specific LED ¹	Second module- specific LED ¹	Meaning
ON	ON	ON	ON	ON	ON	Startup - Initial test
ON	Flashing	OFF	OFF	OFF	OFF	Waiting for configuration from the Modular Safety Controller
ON	ON	OFF	OFF	See the module-specific tables ¹		Received configuration from the Modular Safety Controller

¹ Two LEDs indicate the communication protocol status. These LEDs are described in the module-specific tables.

Common LED Indicators for Troubleshooting

The following table describes the states of the common LED indicators between the different communication expansion modules, assuming the power (**PWR**) indicator is illuminated:

Detected error	RUN green	E IN red	E EX red	First module-specific LED ¹	Second module-specific LED ¹	Solution
Internal microcontroller error detected.	OFF	2 flashes	OFF	See the module-specific tables ¹		Replace the product if the condition persists after reboot.
Internal board error detected.	OFF	3 flashes	OFF			
Configuration error detected.	OFF	5 flashes	OFF			Verify correct configuration.
Fieldbus communication error detected.	OFF	5 flashes	OFF			Verify the fieldbus connections.
Fieldbus communication interruption detected.	OFF	ON	OFF			Verify wiring, connectors, and state of the fieldbus master.
Duplicate addresses detected on the fieldbus.	OFF	5 flashes	5 flashes			Set a correct fieldbus address
¹ Two LEDs indicate the communication status. These LEDs are described in the module-specific tables.						

NOTE: The LED frequency of flashing is: ON for 300 ms and OFF for 400 ms with an interval between flash sequences of 1 s.

Data Provided via Fieldbus

Overview

The fieldbus expansion module exports the system state and diagnostics of the I/Os configured on the Modular Safety Controller.

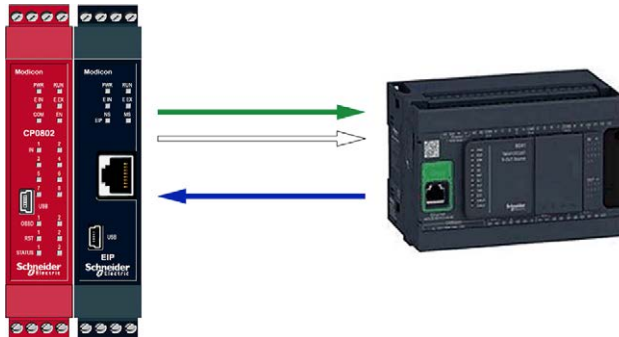

- Green arrow** I/O state and feedback
- White arrow** I/O diagnostic
- Blue arrow** Input from logic controller

Overview of Process Data Map

If the Modular Safety Controller is connected to a fieldbus, it can receive and send I/O data from and to a connected device. This data is the process data map. The process data map is divided into the following sections:

Direction ⁽¹⁾	Common Name	Length	Usage
Out	Fieldbus Inputs	4 bytes	Data can be used for non-safety-related purposes by the logic controller. Refer to Fieldbus Inputs (see page 25).
In	System Status	1 byte	Basic status information about the Modular Safety Controller: online/offline; presence of diagnostic messages. Refer to System Status (see page 25).
In	Input Status	16 bytes	States of the digital inputs of the Modular Safety Controller and the I/O expansion modules. Refer to Input Status (see page 25).
In	Fieldbus Input Feedback	4 bytes	Mirror of the Fieldbus Inputs received by the logic controller. Refer to Fieldbus Inputs (see page 25).

⁽¹⁾As seen from the perspective of the fieldbus master:

Out The data is received by the communication module from the fieldbus system and transmitted to the Modular Safety Controller

In The Modular Safety Controller provides the data and the communication module makes it available to the fieldbus system.

Direction ⁽¹⁾	Common Name	Length	Usage
In	Probe Status	4 bytes	State of the probe bits. The probes allow you to obtain information on the state of function blocks which are not immediately connected to physical inputs as input function blocks, but which are located downstream in the SoSafe Configurable project. Refer to Probe Status (see page 26).
In	Safety-related Output Status	4 bytes	State of the Safety-related Outputs (OSSD) of the Modular Safety Controller and potential I/O expansion modules. Refer to Diagnostics Codes for Safety-related Output Function Blocks (see page 29).
In	Analog Data	64 bytes	State of Analog values. Refer to Diagnostics Codes for Input Function Blocks (see page 26).
In	CPU 0 Error	9 bytes	Detailed Error information on CPU 0 of the Modular Safety Controller
In	CPU 1 Error	9 bytes	Detailed Error information on CPU 1 of the Modular Safety Controller
In	Input Diagnostic	32 bytes	These values specify which error or alert has been detected on which input function block. Refer to Diagnostics Codes for Input Function Blocks (see page 26).
In	Safety-related Output Diagnostic	32 bytes	These values specify which error or alert has been detected for which output function block. Refer to Diagnostics Codes for Safety-related Output Function Blocks (see page 29).
In	Project CRC	2 bytes	16 bit CRC of the project running on the Modular Safety Controller
<p>⁽¹⁾As seen from the perspective of the fieldbus master:</p> <p>Out The data is received by the communication module from the fieldbus system and transmitted to the Modular Safety Controller</p> <p>In The Modular Safety Controller provides the data and the communication module makes it available to the fieldbus system.</p>			

The process data map is represented on the Monitor screen of BUS Configurator by means of checkboxes. If a checkbox is checked, the value of the corresponding bit is 1. If a checkbox is not checked, the value of the corresponding bit is 0.

The fieldbus modules have a common set of data that is provided by the Modular Safety Controller.

The data accessible via fieldbus modules with XPSMCMCO0000• SV2.0 and greater is documented in the tables of section Module Characteristics ([see page 31](#)). Consider that each fieldbus has its own tables.

As not all complete information can fit into the process data map for each fieldbus system, some data are available through acyclic communication where applicable.

Fieldbus Inputs, System status, Input status, Fieldbus Inputs feedback, Probe status and Safety-related Output status are available in the cyclic process image, while Input and Safety-related Output Diagnostics, detected system errors and the XPSMCM• Modular Safety Controller system program CRC are accessible as acyclic data.

The process image has a fixed size with subsections for each information group: there are sections showing the status of the XPSMCM• inputs, the status of the probes, the status of the safety-related outputs and, if the analog module is present, the measured analog values.

If there is a fieldbus module in the system, SoSafe Configurable includes in the report a table with the addresses for inputs, fieldbus inputs, probes and safety-related outputs in the project with the appropriate fieldbus syntax.

Fieldbus Inputs

The Fieldbus Inputs section of the process data map allow a connected device to cyclically send up to 32 ON/OFF status which can be used as non-safety-related inputs in the SoSafe Configurable project.

System Status

The System status section of the process data map provides the following bits:

- Bit 0: Modular Safety Controller online state
- Bit 1: Diagnostic presence
- Bit 2: Error presence

The acyclic data block for diagnostics or errors contains valid values only if the corresponding bit in the status byte is set to 1.

Input Status

The section of the process data map for the states of the inputs has a size of 16 bytes and contains the states of up to 128 inputs.

The order of the modules and the allocated bits is as shown in the following table.

If two or more modules of the same type are installed the one with the lowest node number is shown first.

Module	Bit
XPSMCMCP0802•/XPSMCMC10804•	8
XPSMCMX0802•	8
XPSMCMDI1600•	16
XPSMCMDI0800•	8
XPSMCMDI1200MT•	16
XPSMCMEN0200TT•/XPSMCMEN0200HT•/XPSMCMEN0200SC•	8
XPSMCMEN0100TT•/XPSMCMEN0100HT•/XPSMCMEN0100SC•	8
XPSMCMEN0200•	8
XPSMCMAI0400•	8
XPSMCMX0804•	8

Probe Status

The section of the process data map for the states of the probes has a size of 4 bytes and contains the status of up to 32 probes that can be included in the SoSafe Configurable project.

Safety-Related Output Status

The section of the process data map for the states of the Safety-related Output has a size of 4 bytes and contains the status of up to 32 outputs.

The order of the modules and the allocated bits is as shown in the following table.

If two or more modules of the same type are installed the one with the lowest node number is first.

The number of bits used to represent the status of a Safety-related Output function block depends on the type of Safety-related Output selected:

- One dual-channel Safety-related Output is represented with 1 bit.
- One single-channel Safety-related Outputs is represented with 1 bit.
- Two single-channel Safety-related Outputs combined in a dual-channel are represented with 2 bits.

Module	Bit
XPSMCMCP0802•	2
XPSMCMC10804•	4
XPSMCMMX0802•	2
XPSMCMDO0002•	2
XPSMCMDO0004•	4
XPSMCMRO0004•	4
XPSMCMRO0004DA•	4
XPSMCMDO00042A•	4
XPSMCMMX0804•	4
XPSMCMDO0004S•	4

Diagnostics Codes for Input Function Blocks

Each input function block can generate a diagnostic code.

When the Input function block is connected correctly, the diagnostic code is OK and is not transmitted via the fieldbus.

If an error on the Input function block is detected, the system transmits two bytes via the fieldbus with the following information:

- Index of the Input function block
- Diagnostic code of the Input function block

The Diagnostics code field for an Input function block can contain the following decimal values.

Code	Diagnostic message	Explanation
1	No signal edge transition detected	Both sets of contacts must first be reset before they can be evaluated by the function block.
2	Synchronization time exceeded	Both switches have to modify state within the defined synchronization time.
3	Synchronization time exceeded hand 1	Incorrect operation on one side of a two-hands switch.
4	Synchronization time exceeded hand 2	Incorrect operation on one side of a two-hands switch.
7	Selector switch inconsistent	The selector should not have more than one input set.
8	Switch disconnected	The selector should have at least one input set.
10	OUT_TEST error detected	OUT_TEST diagnostic tests were unsuccessful.
11	Redundant input mismatch	Redundancy verification unsuccessful on input.
13	OUT_TEST diagnostics wiring error	Test output not connected to the correct input.
14	Output OK, but input connected to 24 Vdc.	Invalid test input connection.
15	Short circuit between photo cell test and photo cell input.	Photo cell response time error detected.
16	No response from photo cell.	The test signal on the photo cell emitter is not detected by the receiver.
17	Short circuit between photo cells.	The test signal is present on two different photo cells.
18	Safety Mat not connected.	Incorrect mat connection.
19	Output inconsistent with feedback.	The test signal on input is present on more than one OUT_TEST.
20	Connection incorrect.	The test signal is present on more than one input.
21	OUT_TEST error detected.	The test signal on the input is not present on the OUT_TEST.
22	Redundant OUT_TEST mismatch.	Redundancy verification unsuccessful on OUT_TEST.
23	Speed monitoring module- proximity sensor not detected	The proximity sensor is not detected or is inoperable.
24	Speed monitoring module- encoder not detected	Verify whether the encoder is powered and wired correctly.
25	Speed monitoring module- encoder, Proximity not detected	Verify whether the proximity sensor of the encoder is powered and wired correctly.
26	Speed monitoring module- Proximity1, Proximity2 not detected	One of the two proximity sensors is not connected.

(1) Diagnostics code 133, 134 and 137 are not represented by the LEDs of XPSMCMCP0802• and XPSMCMC10804•.

NOTE: Codes not listed are reserved.

Code	Diagnostic message	Explanation
27	Speed monitoring module- encoder1, encoder2 not detected	One of the two encoders is not connected.
28	Speed monitoring module- error congruence frequencies	Redundancy verification error detected during measurement.
29	Speed monitoring module- encoder supply not detected	Encoder incorrectly powered.
30	Error detected at speed monitoring module	Incorrect encoder signal
31	The selected threshold does not exist	-
32	Frequency at input Encoder 1 is too high	-
33	Frequency at input Encoder 2 is too high	-
34	Frequency at input Proximity 1 is too high	-
35	Frequency at input Proximity 2 is too high	-
40	The signal current supplied by the sensor is below the minimum threshold value	The measured value is below the minimum threshold value
41	The signal current supplied by the sensor is above the maximum threshold value	The measured value is above the maximum threshold value
42	Sensor is not connected or measured value is below the minimum threshold value	-
43	Incorrect current supply by the device to the sensor	The current supplied by the device to the sensor is too high
44	Incorrect current supply by the sensor to the device	The current supplied by the sensor to the device is above the maximum permissible value
53	Mismatch between redundant channels readings	The mismatch between the two channels is out of the threshold
54	Sensor 1 signal current below the minimum allowed value	The analog reading on channel 1 is under the minimum threshold
55	Sensor 2 signal current below the minimum allowed value	The analog reading on channel 2 is under the minimum threshold
56	Sensor 1 signal current exceeds the maximum allowed value	The analog reading on channel 1 is over the maximum threshold
57	Sensor 2 signal current exceeds the maximum allowed value	The analog reading on channel 2 is over the maximum threshold
58	Unconnected sensor 1	The sensor on channel 1 is not connected or the reading is under the minimum threshold
59	Unconnected sensor 2	The sensor on channel 2 is not connected or the reading is under the minimum threshold
60	Sensor 1 supply overload	The power supply current for channel 1 is too high

(1) Diagnostics code 133, 134 and 137 are not represented by the LEDs of XPSMCMCP0802• and XPSMCMC10804•.

NOTE: Codes not listed are reserved.

Code	Diagnostic message	Explanation
61	Sensor 1 supply overload	The power supply current for channel 2 is too high
62	Current value at sensor 1 input too high	The analog reading on channel 1 is too high
63	Current value at sensor 2 input too high	The analog reading on channel 2 is too high
133 ⁽¹⁾	Two hand operation is not simultaneously	Two-hand switches must modify state within the defined synchronization time
134 ⁽¹⁾	Missing StartUp Test	Start up test unsuccessful
137 ⁽¹⁾	Missing Restart	The input has manual reset and has not been restarted
(1) Diagnostics code 133, 134 and 137 are not represented by the LEDs of XPSMCMCP0802• and XPSMCMC10804•.		
NOTE: Codes not listed are reserved.		

Diagnostics Codes for Safety-Related Output Function Blocks

Each Safety-related Output function block can generate a diagnostic code.

When the Safety-related Output function block is connected correctly, the diagnostic code is OK and is not exported to the fieldbus; when an error on the Safety-related Output function block is detected, the system exports 2 bytes to the fieldbus with the following information:

- Index of the Safety-related Output function block
- Diagnostic code of the Safety-related Output function block

The Diagnostics code field for a Safety-related Output function block can contain the following decimal values.

Code	Error message	Explanation	Temporary inhibition, resets when conditions become valid	Blocking, necessary restart of the controller after fixing the blocking condition
1	Enable not detected	Modular Safety Controller inputs pin 2,3 not at 24V	x	-
2	Waiting Restart	Restart signal required to activate output	x	-
3	No K1/K2 feedback detected	No valid feedback from external relays detected	-	x
4	Waiting for internal synchronization	Internal microcontrollers not synchronized	x	-
5	No OSSD power supply	Supply for outputs is missing	x	-
6	Maximum restart time exceeded	Duration of positive restart pulse too long	x	-
NOTE: Codes not listed are reserved.				

Code	Error message	Explanation	Temporary inhibition, resets when conditions become valid	Blocking, necessary restart of the controller after fixing the blocking condition
7	Incorrect K1/K2 feedback	Signal at the FBK_K input does not change within the defined time (applicable to XPSMCMRO0004 and XPSMCMRO0004DA modules configured in Cat.2 (ISO 13849-1) wiring)	-	x
8	Waiting for K1/K2 feedback	External relays did not react to a commanded change of state	x	-
9	OSSD Overload	The current drained from the OSSD is too high	x	-
10	External voltage at OSSD	The OSSD cannot be driven to 0V level due to external mis-wiring (Load connected to 24V instead of 0V)	x	-
NOTE: Codes not listed are reserved.				

System Errors

System errors (only for internal usage) are available via acyclic access; the members of the data set provide detailed information on errors detected by the Modular Safety Controller processors. (Refer to chapter "Error Codes" on the Library and Programming Guide).

Byte and Word Order

32-bit values used in the XPSMCMCO0000• fieldbus communication module and mapped to data entities of a smaller size, are mapped as little-endian, least significant word first.

For example, a hexadecimal value of 0xAABBCCDD would be mapped into two consecutive Modbus registers as follows:

- Register 0: 0xCCDD
- Register 1: 0xAABB

Floating Point Values

Floating-point numbers (exact name of the data type depends on the fieldbus system) are encoded according to IEEE 754 standard.

Section 1.2

Module Characteristics

What Is in This Section?

This section contains the following topics:

Topic	Page
General Module Characteristics	32
XPSMCMCO0000CO• CANopen	33
XPSMCMCO0000CO• CANopen - Mapping Information	35
XPSMCMCO0000EC• EtherCAT	46
XPSMCMCO0000EC• EtherCAT - Mapping Information	48
XPSMCMCO0000EI• EtherNet/IP	57
XPSMCMCO0000EI• EtherNet/IP - Mapping Information	59
XPSMCMCO0000MB• Modbus	65
XPSMCMCO0000MB• Modbus RTU - Mapping Information	67
XPSMCMCO0000EM• Modbus TCP	75
XPSMCMCO0000EM• Modbus TCP - Mapping Information	77
XPSMCMCO0000PB• Profibus	84
XPSMCMCO0000PB• Profibus - Mapping Information	86

General Module Characteristics

Presentation

General characteristics	
Rated voltage	24 Vdc \pm 20 % (PELV supply)
Dissipated power	3 W maximum
Overvoltage category	II
Ambient operating temperature	-10...+55 °C (14...131 °F)
Storage temperature	-20...+85 °C (-4...185 °F)
Relative humidity	10...95%
Maximum operation altitude	2000 m (6562 ft)
Pollution degree	2
Vibration resistance (IEC/EN 61496-1)	+/- 0.35 mm (0.014 in) 10...55 Hz
Shock resistance (IEC/EN 61496-1)	10 g (16 ms half-sine)
EMC Category	Zone B
Weight	0.125 kg (4.4 Oz)
Mini B-USB	Used for configuration of the fieldbus module with the BUS Configurator software.

The following table lists the Mean Time to Failure (MTTF) in years for the fieldbus modules:

Module reference	Fieldbus	Mean Time to Failure (MTTF) in years at an operating temperature of 30° C (86° F)
XPSMCMCO0000CO•	CANopen	196
XPSMCMCO0000EC•	EtherCAT	212
XPSMCMCO0000EI•	EtherNet/IP	212
XPSMCMCO0000MB•	Modbus Serial	245
XPSMCMCO0000EM•	Modbus TCP/IP	212
XPSMCMCO0000PB•	Profibus DP	247

NOTE: For the characteristics common to all modules, refer to General Characteristics (see *Modular Safety Controller, Hardware Guide*).

XPSMCMCO0000CO• CANopen

LED Indicators

The **PWR**, **RUN**, **E IN** and **E EX** LED indicators are present on the module, they are described in the sections Common LEDs for Operation (*see page 21*) and in Common LED Indicators for Troubleshooting (*see page 22*).

The following table presents the LED indicator **CAN RUN**:

State	Indication
OFF	No power.
Steady green	Online, connected.
Flashes slow green	Operating state Pre-Operational.
Periodic single green flash	Operating state Stopped.
Flashes fast green	Baud rate detection in progress.
Steady red	Fieldbus not operational.
Operating states mentioned in the table according to the CANopen state machine	

The following table presents the LED indicator **ERR**:

State	Indication
OFF	No error detected.
Periodic single red flash	A fieldbus error counter has reached an alert level.
Fast red flashing	Layer Setting Service (LSS) operational.
Periodic double red flash	Network monitoring event: node guarding or heartbeat not detected.
Steady red	Fieldbus not operational.

Connector Details

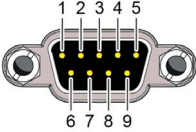
Module-specific characteristics	XPSMCMCO0000CO•
Reference description	CAN: CANopen non-safety-related fieldbus module
Output and PIN number	DB9 - male 
Wiring	Pin/ Signal 1/ not connected 2/ CAN_L 3/ CAN_GND 4/ not connected 5/ CAN_SHLD 6/ not connected 7/ CAN_H 8/ not connected 9/ not connected Housing CAN_SHIELD
Baudrate	10 kbit/s ...1 Mbit/s

XPSMCMCO0000CO• CANopen - Mapping Information

Device Identification

Item	Value	Object Index	Sub-Index	Remarks
Vendor ID	0x0700005A	1018 hex	01 hex	Vendor ID for Schneider Electric Machine Control
Product Code	0x00B6B3D	1018 hex	02 hex	Product code for the XPSMCM CANopen module
Revision Number	0x00020101	1018 hex	03 hex	Reflects the firmware version of the device (i.e. 0x00020101 means SV2.1.1)
Vendor Name	'Schneider Electric'	-	-	-
Product Name	'XPSMCMCO0000CO'	1008 hex	00 hex	-

Cyclic Data Access - PDO Predefined Connection Set

PDO	Name	Length	PDO Object	Mapping Object	Remarks
RxPDO 1	RPDO 1 - Fieldbus Inputs	4 Byte	1400 hex	1600 hex	Part of the standard communication set
RxPDO 2	RPDO 2 - Dummy	1 Byte	1401 hex	1601 hex	Part of the standard communication set; not used; disabled by default
RxPDO 3	RPDO 3 - Dummy	1 Byte	1402 hex	1602 hex	Part of the standard communication set; not used; disabled by default
RxPDO 4	RPDO 4 - Dummy	1 Byte	1403 hex	1603 hex	Part of the standard communication set; not used; disabled by default
TxPDO 1	TPDO 1 - Status, Fieldbus Inputs feedback	8 Byte	1800 hex	1A00 hex	Part of the standard communication set
TxPDO 2	TPDO 2 - Inputs status 1	8 Byte	1801 hex	1A01 hex	Part of the standard communication set
TxPDO 3	TPDO 3 - Inputs status 2	8 Byte	1802 hex	1A02 hex	Part of the standard communication set
TxPDO 4	TPDO 4- Outputs & Probes status	8 Byte	1803 hex	1A03 hex	Part of the standard communication set
TxPDO 5	TPDO 5 – Analog data 1	8 Byte	1804 hex	1A04 hex	Available for user mapping
TxPDO 6	TPDO 6 – Analog data 2	8 Byte	1805 hex	1A05 hex	Available for user mapping
TxPDO 7	TPDO 7 – Analog data 3	8 Byte	1806 hex	1A06 hex	Available for user mapping

PDO	Name	Length	PDO Object	Mapping Object	Remarks
TxPDO 8	TPDO 8 – Analog data 4	8 Byte	1807 hex	1A07 hex	Available for user mapping
TxPDO 9	TPDO 9 – Analog data 5	8 Byte	1808 hex	1A08 hex	Available for user mapping
TxPDO 10	TPDO 10 – Analog data 6	8 Byte	1809 hex	1A09 hex	Available for user mapping
TxPDO 11	TPDO 11 – Analog data 7	8 Byte	180A hex	1A0A hex	Available for user mapping
TxPDO 12	TPDO 12 – Analog data 8	8 Byte	180B hex	1A0B hex	Available for user mapping

Cyclic Data Access - PDO Mapping

PDO Designation	Sub-index	Byte	PDO Object Index	Sub-index	Mapped object Index	Sub-index	Object name
RxPDO 1	01 hex	0	1600 hex	01 hex	2101 hex	01 hex	Fieldbus input byte 0
	02 hex	1	1600 hex	02 hex	2101 hex	02 hex	Fieldbus input byte 1
	03 hex	2	1600 hex	03 hex	2101 hex	03 hex	Fieldbus input byte 2
	04 hex	3	1600 hex	04 hex	2101 hex	04 hex	Fieldbus input byte 3
RxPDO 2	01 hex	0	1601 hex	01 hex	0005 hex	00 hex	Dummy entry (UNSIGNED8)
RxPDO 3	01 hex	0	1602 hex	01 hex	0005 hex	00 hex	Dummy entry (UNSIGNED8)
RxPDO 4	01 hex	0	1603 hex	01 hex	0005 hex	00 hex	Dummy entry (UNSIGNED8)
TxPDO 1	01 hex	0	1A00 hex	01 hex	2001 hex	01 hex	System status
	02 hex	1	1A00 hex	02 hex	0005 hex	00 hex	Dummy entry (UNSIGNED8)
	03 hex	2	1A00 hex	03 hex	0005 hex	00 hex	Dummy entry (UNSIGNED8)
	04 hex	3	1A00 hex	04 hex	0005 hex	00 hex	Dummy entry (UNSIGNED8)
	05 hex	4	1A00 hex	05 hex	2181 hex	01 hex	Fieldbus input byte 0 feedback
	06 hex	5	1A00 hex	06 hex	2181 hex	02 hex	Fieldbus input byte 1 feedback
	07 hex	6	1A00 hex	07 hex	2181 hex	03 hex	Fieldbus input byte 2 feedback
	08 hex	7	1A00 hex	08 hex	2181 hex	04 hex	Fieldbus input byte 3 feedback

PDO Designation	Sub-index	Byte	PDO Object Index	Sub-index	Mapped object Index	Sub-index	Object name
TxPDO 2	01 hex	0	1A01 hex	01 hex	2201 hex	01 hex	Input status byte 0
	02 hex	1	1A01 hex	02 hex	2201 hex	02 hex	Input status byte 1
	03 hex	2	1A01 hex	03 hex	2201 hex	03 hex	Input status byte 2
	04 hex	3	1A01 hex	04 hex	2201 hex	04 hex	Input status byte 3
	05 hex	4	1A01 hex	05 hex	2201 hex	05 hex	Input status byte 4
	06 hex	5	1A01 hex	06 hex	2201 hex	06 hex	Input status byte 5
	07 hex	6	1A01 hex	07 hex	2201 hex	07 hex	Input status byte 6
	08 hex	7	1A01 hex	08 hex	2201 hex	08 hex	Input status byte 7
TxPDO 3	01 hex	0	1A02 hex	01 hex	2201 hex	09 hex	Input status byte 8
	02 hex	1	1A02 hex	02 hex	2201 hex	0A hex	Input status byte 9
	03 hex	2	1A02 hex	03 hex	2201 hex	0B hex	Input status byte 10
	04 hex	3	1A02 hex	04 hex	2201 hex	0C hex	Input status byte 11
	05 hex	4	1A02 hex	05 hex	2201 hex	0D hex	Input status byte 12
	06 hex	5	1A02 hex	06 hex	2201 hex	0E hex	Input status byte 13
	07 hex	6	1A02 hex	07 hex	2201 hex	0F hex	Input status byte 14
	08 hex	7	1A02 hex	08 hex	2201 hex	10 hex	Input status byte 15
TxPDO 4	01 hex	0	1A03 hex	01 hex	2203 hex	01 hex	Probe status byte 0
	02 hex	1	1A03 hex	02 hex	2203 hex	02 hex	Probe status byte 1
	03 hex	2	1A03 hex	03 hex	2203 hex	03 hex	Probe status byte 2
	04 hex	3	1A03 hex	04 hex	2203 hex	04 hex	Probe status byte 3
	05 hex	4	1A03 hex	05 hex	2202 hex	01 hex	Safety-related Output status byte 0
	06 hex	5	1A03 hex	06 hex	2202 hex	02 hex	Safety-related Output status byte 1
	07 hex	6	1A03 hex	07 hex	2202 hex	03 hex	Safety-related Output status byte 2
	08 hex	7	1A03 hex	08 hex	2202 hex	04 hex	Safety-related Output status byte 3
TxPDO 5	01 hex	0-3	1A04 hex	01 hex	2204 hex	01 hex	Analog data float 0
	02 hex	4-7	1A04 hex	02 hex	2204 hex	02 hex	Analog data float 0
TxPDO 6	01 hex	0-3	1A05 hex	01 hex	2204 hex	03 hex	Analog data float 0
	02 hex	4-7	1A05 hex	02 hex	2204 hex	04 hex	Analog data float 0
TxPDO 7	01 hex	0-3	1A06 hex	01 hex	2204 hex	05 hex	Analog data float 0
	02 hex	4-7	1A06 hex	02 hex	2204 hex	06 hex	Analog data float 0

PDO Designation	Sub-index	Byte	PDO Object Index	Sub-index	Mapped object Index	Sub-index	Object name
TxPDO 8	01 hex	0-3	1A07 hex	01 hex	2204 hex	07 hex	Analog data float 0
	02 hex	4-7	1A07 hex	02 hex	2204 hex	08 hex	Analog data float 0
TxPDO 9	01 hex	0-3	1A08 hex	01 hex	2204 hex	09 hex	Analog data float 0
	02 hex	4-7	1A08 hex	02 hex	2204 hex	0A hex	Analog data float 0
TxPDO 10	01 hex	0-3	1A09 hex	01 hex	2204 hex	0B hex	Analog data float 0
	02 hex	4-7	1A09 hex	02 hex	2204 hex	0C hex	Analog data float 0
TxPDO 11	01 hex	0-3	1A0A hex	01 hex	2204 hex	0D hex	Analog data float 0
	02 hex	4-7	1A0A hex	02 hex	2204 hex	0E hex	Analog data float 0
TxPDO 12	01 hex	0-3	1A0B hex	01 hex	2204 hex	0F hex	Analog data float 0
	02 hex	4-7	1A0B hex	02 hex	2204 hex	010 hex	Analog data float 0

Vendor Specific Object Index 2001 hex – System Status

Object Type: Array of UNSIGNED8

Subindex	Type	Usage/Name	Default value	Access
00 hex	UNSIGNED8	Number Of Entries	08 hex	RO
01 hex	UNSIGNED8	System status	00 hex	RO
02 hex	UNSIGNED8	Reserved	00 hex	RO
03 hex	UNSIGNED8	Reserved	00 hex	RO
04 hex	UNSIGNED8	Reserved	00 hex	RO
05 hex	UNSIGNED8	Reserved	00 hex	RO
06 hex	UNSIGNED8	Reserved	00 hex	RO
07 hex	UNSIGNED8	Reserved	00 hex	RO
08 hex	UNSIGNED8	Reserved	00 hex	RO

Vendor Specific Object Index 2003 hex – Error Data CPU 0

Object Type: Array of UNSIGNED8

Subindex	Type	Usage/Name	Default value	Access
00 hex	UNSIGNED8	Number Of Entries	08 hex	RO
01 hex	UNSIGNED8	Module ID	00 hex	RO
02 hex	UNSIGNED8	Error code	00 hex	RO
03 hex	UNSIGNED8	Error address byte 0	00 hex	RO
04 hex	UNSIGNED8	Error address byte 1	00 hex	RO
05 hex	UNSIGNED8	Error address byte 2	00 hex	RO
06 hex	UNSIGNED8	Error address byte 3	00 hex	RO
07 hex	UNSIGNED8	CPU firmware version	00 hex	RO
08 hex	UNSIGNED8	Extended code 0 (optional)	00 hex	RO
09 hex	UNSIGNED8	Extended code 1 (optional)	00 hex	RO

Vendor Specific Object Index 2004 hex – Error Data CPU 1

Object Type: Array of UNSIGNED8

Subindex	Type	Usage/Name	Default value	Access
00 hex	UNSIGNED8	Number Of Entries	08 hex	RO
01 hex	UNSIGNED8	Module ID	00 hex	RO
02 hex	UNSIGNED8	Error code	00 hex	RO
03 hex	UNSIGNED8	Error address byte 0	00 hex	RO
04 hex	UNSIGNED8	Error address byte 1	00 hex	RO
05 hex	UNSIGNED8	Error address byte 2	00 hex	RO
06 hex	UNSIGNED8	Error address byte 3	00 hex	RO
07 hex	UNSIGNED8	CPU firmware version	00 hex	RO
08 hex	UNSIGNED8	Extended code 0 (optional)	00 hex	RO
09 hex	UNSIGNED8	Extended code 1 (optional)	00 hex	RO

Vendor Specific Object Index 2005 hex – Input Diagnostics

Object Type: Array of UNSIGNED8

Subindex	Type	Usage/Name	Default value	Access
00 hex	UNSIGNED8	Number Of Entries	20 hex	RO
01 hex	UNSIGNED8	Diagnostic index 0	00 hex	RO
02 hex	UNSIGNED8	Diagnostic code 0	00 hex	RO
03 hex	UNSIGNED8	Diagnostic index 1	00 hex	RO
04 hex	UNSIGNED8	Diagnostic code 1	00 hex	RO
05 hex	UNSIGNED8	Diagnostic index 2	00 hex	RO
06 hex	UNSIGNED8	Diagnostic code 2	00 hex	RO
07 hex	UNSIGNED8	Diagnostic index 3	00 hex	RO
08 hex	UNSIGNED8	Diagnostic code 3	00 hex	RO
09 hex	UNSIGNED8	Diagnostic index 4	00 hex	RO
0A hex	UNSIGNED8	Diagnostic code 4	00 hex	RO
0B hex	UNSIGNED8	Diagnostic index 5	00 hex	RO
0C hex	UNSIGNED8	Diagnostic code 5	00 hex	RO
0D hex	UNSIGNED8	Diagnostic index 6	00 hex	RO
0E hex	UNSIGNED8	Diagnostic code 6	00 hex	RO
0F hex	UNSIGNED8	Diagnostic index 7	00 hex	RO
10 hex	UNSIGNED8	Diagnostic code 7	00 hex	RO
11 hex	UNSIGNED8	Diagnostic index 8	00 hex	RO
12 hex	UNSIGNED8	Diagnostic code 8	00 hex	RO
13 hex	UNSIGNED8	Diagnostic index 9	00 hex	RO
14 hex	UNSIGNED8	Diagnostic code 9	00 hex	RO
15 hex	UNSIGNED8	Diagnostic index 10	00 hex	RO
16 hex	UNSIGNED8	Diagnostic code 10	00 hex	RO
17 hex	UNSIGNED8	Diagnostic index 11	00 hex	RO
18 hex	UNSIGNED8	Diagnostic code 11	00 hex	RO
19 hex	UNSIGNED8	Diagnostic index 12	00 hex	RO
1A hex	UNSIGNED8	Diagnostic code 12	00 hex	RO
1B hex	UNSIGNED8	Diagnostic index 13	00 hex	RO
1C hex	UNSIGNED8	Diagnostic code 13	00 hex	RO
1D hex	UNSIGNED8	Diagnostic index 14	00 hex	RO
1E hex	UNSIGNED8	Diagnostic code 14	00 hex	RO
1F hex	UNSIGNED8	Diagnostic index 15	00 hex	RO

Subindex	Type	Usage/Name	Default value	Access
20 hex	UNSIGNED8	Diagnostic code 15	00 hex	RO

Vendor Specific Object Index 2006 hex – Safety-Related Output Diagnostics

Object Type: Array of UNSIGNED8

Subindex	Type	Usage/Name	Default value	Access
00 hex	UNSIGNED8	Number Of Entries	20 hex	RO
01 hex	UNSIGNED8	Diagnostic index 0	00 hex	RO
02 hex	UNSIGNED8	Diagnostic code 0	00 hex	RO
03 hex	UNSIGNED8	Diagnostic index 1	00 hex	RO
04 hex	UNSIGNED8	Diagnostic code 1	00 hex	RO
05 hex	UNSIGNED8	Diagnostic index 2	00 hex	RO
06 hex	UNSIGNED8	Diagnostic code 2	00 hex	RO
07 hex	UNSIGNED8	Diagnostic index 3	00 hex	RO
08 hex	UNSIGNED8	Diagnostic code 3	00 hex	RO
09 hex	UNSIGNED8	Diagnostic index 4	00 hex	RO
0A hex	UNSIGNED8	Diagnostic code 4	00 hex	RO
0B hex	UNSIGNED8	Diagnostic index 5	00 hex	RO
0C hex	UNSIGNED8	Diagnostic code 5	00 hex	RO
0D hex	UNSIGNED8	Diagnostic index 6	00 hex	RO
0E hex	UNSIGNED8	Diagnostic code 6	00 hex	RO
0F hex	UNSIGNED8	Diagnostic index 7	00 hex	RO
10 hex	UNSIGNED8	Diagnostic code 7	00 hex	RO
11 hex	UNSIGNED8	Diagnostic index 8	00 hex	RO
12 hex	UNSIGNED8	Diagnostic code 8	00 hex	RO
13 hex	UNSIGNED8	Diagnostic index 9	00 hex	RO
14 hex	UNSIGNED8	Diagnostic code 9	00 hex	RO
15 hex	UNSIGNED8	Diagnostic index 10	00 hex	RO
16 hex	UNSIGNED8	Diagnostic code 10	00 hex	RO
17 hex	UNSIGNED8	Diagnostic index 11	00 hex	RO
18 hex	UNSIGNED8	Diagnostic code 11	00 hex	RO
19 hex	UNSIGNED8	Diagnostic index 12	00 hex	RO
1A hex	UNSIGNED8	Diagnostic code 12	00 hex	RO
1B hex	UNSIGNED8	Diagnostic index 13	00 hex	RO
1C hex	UNSIGNED8	Diagnostic code 13	00 hex	RO

Subindex	Type	Usage/Name	Default value	Access
1D hex	UNSIGNED8	Diagnostic index 14	00 hex	RO
1E hex	UNSIGNED8	Diagnostic code 14	00 hex	RO
1F hex	UNSIGNED8	Diagnostic index 15	00 hex	RO
20 hex	UNSIGNED8	Diagnostic code 15	00 hex	RO

Vendor Specific Object Index 2007 hex – Project CRC

Object Type: Array of UNSIGNED8

Subindex	Type	Usage/Name	Default value	Access
00 hex	UNSIGNED8	Number Of Entries	08 hex	RO
01 hex	UNSIGNED8	Project CRC, low byte	00 hex	RO
02 hex	UNSIGNED8	Project CRC, high byte	00 hex	RO
03 hex	UNSIGNED8	Reserved	00 hex	RO
04 hex	UNSIGNED8	Reserved	00 hex	RO
05 hex	UNSIGNED8	Reserved	00 hex	RO
06 hex	UNSIGNED8	Reserved	00 hex	RO
07 hex	UNSIGNED8	Reserved	00 hex	RO
08 hex	UNSIGNED8	Reserved	00 hex	RO

Vendor Specific Object Index 2101 hex – Fieldbus Inputs

Object Type: Array of UNSIGNED8

Subindex	Type	Usage/Name	Default value	Access
00 hex	UNSIGNED8	Number Of Entries	08 hex	RO
01 hex	UNSIGNED8	Fieldbus inputs byte 0	00 hex	RW
02 hex	UNSIGNED8	Fieldbus inputs byte 1	00 hex	RW
03 hex	UNSIGNED8	Fieldbus inputs byte 2	00 hex	RW
04 hex	UNSIGNED8	Fieldbus inputs byte 3	00 hex	RW
05 hex	UNSIGNED8	Reserved	00 hex	RO
06 hex	UNSIGNED8	Reserved	00 hex	RO
07 hex	UNSIGNED8	Reserved	00 hex	RO
08 hex	UNSIGNED8	Reserved	00 hex	RO

Vendor Specific Object Index 2181 hex – Fieldbus Inputs Feedback

Object Type: Array of UNSIGNED8

Subindex	Type	Usage/Name	Default value	Access
00 hex	UNSIGNED8	Number Of Entries	08 hex	RO
01 hex	UNSIGNED8	Fieldbus inputs feedback byte 0	00 hex	RW
02 hex	UNSIGNED8	Fieldbus inputs feedback byte 1	00 hex	RW
03 hex	UNSIGNED8	Fieldbus inputs feedback byte 2	00 hex	RW
04 hex	UNSIGNED8	Fieldbus inputs feedback byte 3	00 hex	RW
05 hex	UNSIGNED8	Reserved	00 hex	RO
06 hex	UNSIGNED8	Reserved	00 hex	RO
07 hex	UNSIGNED8	Reserved	00 hex	RO
08 hex	UNSIGNED8	Reserved	00 hex	RO

Vendor Specific Object Index 2201 hex – Input Status

Object Type: Array of UNSIGNED8

Subindex	Type	Usage/Name	Default value	Access
00 hex	UNSIGNED8	Number Of Entries	10 hex	RO
01 hex	UNSIGNED8	Input status byte 0	00 hex	RO
02 hex	UNSIGNED8	Input status byte 1	00 hex	RO
03 hex	UNSIGNED8	Input status byte 2	00 hex	RO
04 hex	UNSIGNED8	Input status byte 3	00 hex	RO
05 hex	UNSIGNED8	Input status byte 4	00 hex	RO
06 hex	UNSIGNED8	Input status byte 5	00 hex	RO
07 hex	UNSIGNED8	Input status byte 6	00 hex	RO
08 hex	UNSIGNED8	Input status byte 7	00 hex	RO
09 hex	UNSIGNED8	Input status byte 8	00 hex	RO
0A hex	UNSIGNED8	Input status byte 9	00 hex	RO
0B hex	UNSIGNED8	Input status byte 10	00 hex	RO
0C hex	UNSIGNED8	Input status byte 11	00 hex	RO
0D hex	UNSIGNED8	Input status byte 12	00 hex	RO
0E hex	UNSIGNED8	Input status byte 13	00 hex	RO
0F hex	UNSIGNED8	Input status byte 14	00 hex	RO
10 hex	UNSIGNED8	Input status byte 15	00 hex	RO

Vendor Specific Object Index 2202 hex – Safety-related Output Status

Object Type: Array of UNSIGNED8

Subindex	Type	Usage/Name	Default value	Access
00 hex	UNSIGNED8	Number Of Entries	08 hex	RO
01 hex	UNSIGNED8	Safety-related Output status byte 0	00 hex	RO
02 hex	UNSIGNED8	Safety-related Output status byte 1	00 hex	RO
03 hex	UNSIGNED8	Safety-related Output status byte 2	00 hex	RO
04 hex	UNSIGNED8	Safety-related Output status byte 3	00 hex	RO
05 hex	UNSIGNED8	Reserved	00 hex	RO
06 hex	UNSIGNED8	Reserved	00 hex	RO
07 hex	UNSIGNED8	Reserved	00 hex	RO
08 hex	UNSIGNED8	Reserved	00 hex	RO

Vendor Specific Object Index 2203 hex – Probe Status

Object Type: Array of UNSIGNED8

Subindex	Type	Usage/Name	Default value	Access
00 hex	UNSIGNED8	Number Of Entries	08 hex	RO
01 hex	UNSIGNED8	Probe status byte 0	00 hex	RO
02 hex	UNSIGNED8	Probe status byte 1	00 hex	RO
03 hex	UNSIGNED8	Probe status byte 2	00 hex	RO
04 hex	UNSIGNED8	Probe status byte 3	00 hex	RO
05 hex	UNSIGNED8	Reserved	00 hex	RO
06 hex	UNSIGNED8	Reserved	00 hex	RO
07 hex	UNSIGNED8	Reserved	00 hex	RO
08 hex	UNSIGNED8	Reserved	00 hex	RO

Vendor Specific Object Index 2204 hex – Analog Data

Object Type: Array of REAL32

Subindex	Type	Usage/Name	Default value	Access
00 hex	UNSIGNED8	Number Of Entries	10 hex	RO
01 hex	REAL32	Analog data float 0	0.0f	RO
02 hex	REAL32	Analog data float 1	0.0f	RO
03 hex	REAL32	Analog data float 2	0.0f	RO
04 hex	REAL32	Analog data float 3	0.0f	RO
05 hex	REAL32	Analog data float 4	0.0f	RO
06 hex	REAL32	Analog data float 5	0.0f	RO

Subindex	Type	Usage/Name	Default value	Access
07 hex	REAL32	Analog data float 6	0.0f	RO
08 hex	REAL32	Analog data float 7	0.0f	RO
09 hex	REAL32	Analog data float 8	0.0f	RO
0A hex	REAL32	Analog data float 9	0.0f	RO
0B hex	REAL32	Analog data float 10	0.0f	RO
0C hex	REAL32	Analog data float 11	0.0f	RO
0D hex	REAL32	Analog data float 12	0.0f	RO
0E hex	REAL32	Analog data float 13	0.0f	RO
0F hex	REAL32	Analog data float 14	0.0f	RO
10 hex	REAL32	Analog data float 15	0.0f	RO

Acyclic Data Access

The data of the XPSMCMCO0000CO can be accessed acyclically via SDO (service data object) access. The addressing schema uses indexes and sub-indexes.

The listed vendor specific objects are available to acyclic access.

XPSMCMCO0000EC• EtherCAT

LED Indicators

The **PWR**, **RUN**, **E IN** and **E EX** LED indicators are present on the module, they are described in the sections Common LEDs for Operation (*see page 21*) and in Common LED Indicators for Troubleshooting (*see page 22*).

The following table presents the LED indicator **ECT RUN**:

State	Indication
OFF	Operating state Init or no power.
Green	Operating state Operational.
Flashes green	Operating state Pre-Operational.
Flashes green once	Operating state Safe-Operational.
Red	System locked
Operating states mentioned in the table according to the EtherCAT state machine.	

The following table presents the LED indicator **ERR**:

State	Indication
OFF	No error or no power.
Flashes red	Configuration not valid. Operating state transition requested by master not possible.
Flashes red twice	Timeout EtherCAT SynchManager watchdog.
Red	Error detected, fieldbus module not operational.

Connector Details

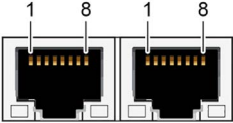
Module-specific characteristics	XPSMCMCO0000EC•
Reference description	ECT: EtherCAT non-safety-related fieldbus module
Output and PIN number	RJ45 - female 
Wiring	Pin/ Signal 1/ Tx+ 2/ Tx- 3/ Rx+ 4/ not connected 5/ not connected 6/ Rx- 7/ not connected 8/ not connected
Baudrate	100 Mbit/s (full duplex)

XPSMCMCO0000EC• EtherCAT - Mapping Information

Device Identification

Item	Value	Object Index	Sub-Index	Remarks
Vendor ID	0x0800005A	1018 hex	01 hex	Vendor ID for Schneider Electric SE
Product Code	0x00000400	1018 hex	02 hex	Product code for the XPSMCM EtherCAT module
Revision Number	0x00020101	1018 hex	03 hex	Reflects the firmware version of the device
Vendor Name	'Schneider Electric'	-	-	-
Product Name	'XPSMCMCO0000EC'	1008 hex	00 hex	-

Cyclic Data Access - PDO Overview

PDO	Name	Length	Mapping	Remarks
RxPDO 1	RxPDO 1	4 Byte	1600 hex	-
TxPDO 1	TxPDO 1	94 Byte	1A00 hex	-

Cyclic Data Access - PDO Mapping

RxPDO Index 1600 hex		Mapped object		Name
Sub-index	Byte	Index	Sub-index	
01 hex	0	2101 hex	01 hex	Fieldbus input byte 0
02 hex	1	2101 hex	02 hex	Fieldbus input byte 1
03 hex	2	2101 hex	03 hex	Fieldbus input byte 2
04 hex	3	2101 hex	04 hex	Fieldbus input byte 3

TxPDO Index 1A00 hex		Mapped object		Name
Sub-index	Byte	Index	Sub-index	
01 hex	0	2001 hex	01 hex	System status
02 hex	1	2001 hex	02 hex	Reserved_2001_02
03 hex	2	2201 hex	01 hex	Input status byte 0
04 hex	3	2201 hex	02 hex	Input status byte 1
05 hex	4	2201 hex	03 hex	Input status byte 2
06 hex	5	2201 hex	04 hex	Input status byte 3

TxPDO Index 1A00 hex		Mapped object		Name
Sub-index	Byte	Index	Sub-index	
07 hex	6	2201 hex	05 hex	Input status byte 4
08 hex	7	2201 hex	06 hex	Input status byte 5
09 hex	8	2201 hex	07 hex	Input status byte 6
0A hex	9	2201 hex	08 hex	Input status byte 7
0B hex	10	2201 hex	09 hex	Input status byte 8
0C hex	11	2201 hex	0A hex	Input status byte 9
0D hex	12	2201 hex	0B hex	Input status byte 10
0E hex	13	2201 hex	0C hex	Input status byte 11
0F hex	14	2201 hex	0D hex	Input status byte 12
10 hex	15	2201 hex	0E hex	Input status byte 13
11 hex	16	2201 hex	0F hex	Input status byte 14
12 hex	17	2201 hex	10 hex	Input status byte 15
13 hex	18	2181 hex	01 hex	Fieldbus input byte 0 feedback
14 hex	19	2181 hex	02 hex	Fieldbus input byte 1 feedback
15 hex	20	2181 hex	03 hex	Fieldbus input byte 2 feedback
16 hex	21	2181 hex	04 hex	Fieldbus input byte 3 feedback
17 hex	22	2203 hex	01 hex	Probe status byte 0
18 hex	23	2203 hex	02 hex	Probe status byte 1
19 hex	24	2203 hex	03 hex	Probe status byte 2
1A hex	25	2203 hex	04 hex	Probe status byte 3
1B hex	26	2202 hex	01 hex	Safety-related Output status byte 0
1C hex	27	2202 hex	02 hex	Safety-related Output status byte 1
1D hex	28	2202 hex	03 hex	Safety-related Output status byte 2
1E hex	29	2202 hex	04 hex	Safety-related Output status byte 3
1F hex	30-33	2204 hex	01 hex	Analog data float 0
20 hex	34-37	2204 hex	02 hex	Analog data float 1
21 hex	38-41	2204 hex	03 hex	Analog data float 2
22 hex	42-45	2204 hex	04 hex	Analog data float 3
23 hex	46-49	2204 hex	05 hex	Analog data float 4
24 hex	50-53	2204 hex	06 hex	Analog data float 5
25 hex	54-57	2204 hex	07 hex	Analog data float 6
26 hex	58-61	2204 hex	08 hex	Analog data float 7
27 hex	62-65	2204 hex	09 hex	Analog data float 8

TxPDO Index 1A00 hex		Mapped object		Name
Sub-index	Byte	Index	Sub-index	
28 hex	66-69	2204 hex	0A hex	Analog data float 9
29 hex	79-73	2204 hex	0B hex	Analog data float 10
2A hex	74-77	2204 hex	0C hex	Analog data float 11
2B hex	78-81	2204 hex	0D hex	Analog data float 12
2C hex	82-85	2204 hex	0E hex	Analog data float 13
2D hex	86-89	2204 hex	0F hex	Analog data float 14
2E hex	90-93	2204 hex	10 hex	Analog data float 15

Vendor Specific Object Index 2001 hex – System Status

Object Type: Array of UNSIGNED8

Subindex	Type	Usage/Name	Default value	Access
00 hex	UNSIGNED8	Number Of Entries	02 hex	RO
01 hex	UNSIGNED8	System status	00 hex	RO
02 hex	UNSIGNED8	Reserved_2001_02	00 hex	RO

Vendor Specific Object Index 2003 hex – Error data CPU 0

Object Type: Array of UNSIGNED8

Subindex	Type	Usage/Name	Default value	Access
00 hex	UNSIGNED8	Number Of Entries	09 hex	RO
01 hex	UNSIGNED8	Module ID	00 hex	RO
02 hex	UNSIGNED8	Error code	00 hex	RO
03 hex	UNSIGNED8	Error address byte 0	00 hex	RO
04 hex	UNSIGNED8	Error address byte 1	00 hex	RO
05 hex	UNSIGNED8	Error address byte 2	00 hex	RO
06 hex	UNSIGNED8	Error address byte 3	00 hex	RO
07 hex	UNSIGNED8	CPU firmware version	00 hex	RO
08 hex	UNSIGNED8	Extended code 0 (optional)	00 hex	RO
09 hex	UNSIGNED8	Extended code 1 (optional)	00 hex	RO

Vendor Specific Object Index 2004 hex – Error data CPU 1

Object Type: Array of UNSIGNED8

Subindex	Type	Usage/Name	Default value	Access
00 hex	UNSIGNED8	Number Of Entries	09 hex	RO
01 hex	UNSIGNED8	Module ID	00 hex	RO
02 hex	UNSIGNED8	Error code	00 hex	RO
03 hex	UNSIGNED8	Error address byte 0	00 hex	RO
04 hex	UNSIGNED8	Error address byte 1	00 hex	RO
05 hex	UNSIGNED8	Error address byte 2	00 hex	RO
06 hex	UNSIGNED8	Error address byte 3	00 hex	RO
07 hex	UNSIGNED8	CPU firmware version	00 hex	RO
08 hex	UNSIGNED8	Extended code 0 (optional)	00 hex	RO
09 hex	UNSIGNED8	Extended code 1 (optional)	00 hex	RO

Vendor Specific Object Index 2005 hex – Input Diagnostics

Object Type: Array of UNSIGNED8

Subindex	Type	Usage/Name	Default value	Access
00 hex	UNSIGNED8	Number Of Entries	20 hex	RO
01 hex	UNSIGNED8	Diagnostic index 0	00 hex	RO
02 hex	UNSIGNED8	Diagnostic code 0	00 hex	RO
03 hex	UNSIGNED8	Diagnostic index 1	00 hex	RO
04 hex	UNSIGNED8	Diagnostic code 1	00 hex	RO
05 hex	UNSIGNED8	Diagnostic index 2	00 hex	RO
06 hex	UNSIGNED8	Diagnostic code 2	00 hex	RO
07 hex	UNSIGNED8	Diagnostic index 3	00 hex	RO
08 hex	UNSIGNED8	Diagnostic code 3	00 hex	RO
09 hex	UNSIGNED8	Diagnostic index 4	00 hex	RO
0A hex	UNSIGNED8	Diagnostic code 4	00 hex	RO
0B hex	UNSIGNED8	Diagnostic index 5	00 hex	RO
0C hex	UNSIGNED8	Diagnostic code 5	00 hex	RO
0D hex	UNSIGNED8	Diagnostic index 6	00 hex	RO
0E hex	UNSIGNED8	Diagnostic code 6	00 hex	RO
0F hex	UNSIGNED8	Diagnostic index 7	00 hex	RO

Subindex	Type	Usage/Name	Default value	Access
10 hex	UNSIGNED8	Diagnostic code 7	00 hex	RO
11 hex	UNSIGNED8	Diagnostic index 8	00 hex	RO
12 hex	UNSIGNED8	Diagnostic code 8	00 hex	RO
13 hex	UNSIGNED8	Diagnostic index 9	00 hex	RO
14 hex	UNSIGNED8	Diagnostic code 9	00 hex	RO
15 hex	UNSIGNED8	Diagnostic index 10	00 hex	RO
16 hex	UNSIGNED8	Diagnostic code 10	00 hex	RO
17 hex	UNSIGNED8	Diagnostic index 11	00 hex	RO
18 hex	UNSIGNED8	Diagnostic code 11	00 hex	RO
19 hex	UNSIGNED8	Diagnostic index 12	00 hex	RO
1A hex	UNSIGNED8	Diagnostic code 12	00 hex	RO
1B hex	UNSIGNED8	Diagnostic index 13	00 hex	RO
1C hex	UNSIGNED8	Diagnostic code 13	00 hex	RO
1D hex	UNSIGNED8	Diagnostic index 14	00 hex	RO
1E hex	UNSIGNED8	Diagnostic code 14	00 hex	RO
1F hex	UNSIGNED8	Diagnostic index 15	00 hex	RO
20 hex	UNSIGNED8	Diagnostic code 15	00 hex	RO

Vendor Specific Object Index 2006 hex – Safety-Related Output Diagnostics

Object Type: Array of UNSIGNED8

Subindex	Type	Usage/Name	Default value	Access
00 hex	UNSIGNED8	Number Of Entries	20 hex	RO
01 hex	UNSIGNED8	Diagnostic index 0	00 hex	RO
02 hex	UNSIGNED8	Diagnostic code 0	00 hex	RO
03 hex	UNSIGNED8	Diagnostic index 1	00 hex	RO
04 hex	UNSIGNED8	Diagnostic code 1	00 hex	RO
05 hex	UNSIGNED8	Diagnostic index 2	00 hex	RO
06 hex	UNSIGNED8	Diagnostic code 2	00 hex	RO
07 hex	UNSIGNED8	Diagnostic index 3	00 hex	RO
08 hex	UNSIGNED8	Diagnostic code 3	00 hex	RO
09 hex	UNSIGNED8	Diagnostic index 4	00 hex	RO
0A hex	UNSIGNED8	Diagnostic code 4	00 hex	RO
0B hex	UNSIGNED8	Diagnostic index 5	00 hex	RO
0C hex	UNSIGNED8	Diagnostic code 5	00 hex	RO

Subindex	Type	Usage/Name	Default value	Access
0D hex	UNSIGNED8	Diagnostic index 6	00 hex	RO
0E hex	UNSIGNED8	Diagnostic code 6	00 hex	RO
0F hex	UNSIGNED8	Diagnostic index 7	00 hex	RO
10 hex	UNSIGNED8	Diagnostic code 7	00 hex	RO
11 hex	UNSIGNED8	Diagnostic index 8	00 hex	RO
12 hex	UNSIGNED8	Diagnostic code 8	00 hex	RO
13 hex	UNSIGNED8	Diagnostic index 9	00 hex	RO
14 hex	UNSIGNED8	Diagnostic code 9	00 hex	RO
15 hex	UNSIGNED8	Diagnostic index 10	00 hex	RO
16 hex	UNSIGNED8	Diagnostic code 10	00 hex	RO
17 hex	UNSIGNED8	Diagnostic index 11	00 hex	RO
18 hex	UNSIGNED8	Diagnostic code 11	00 hex	RO
19 hex	UNSIGNED8	Diagnostic index 12	00 hex	RO
1A hex	UNSIGNED8	Diagnostic code 12	00 hex	RO
1B hex	UNSIGNED8	Diagnostic index 13	00 hex	RO
1C hex	UNSIGNED8	Diagnostic code 13	00 hex	RO
1D hex	UNSIGNED8	Diagnostic index 14	00 hex	RO
1E hex	UNSIGNED8	Diagnostic code 14	00 hex	RO
1F hex	UNSIGNED8	Diagnostic index 15	00 hex	RO
20 hex	UNSIGNED8	Diagnostic code 15	00 hex	RO

Vendor Specific Object Index 2007 hex – Project CRC

Object Type: Array of UNSIGNED8

Subindex	Type	Usage/Name	Default value	Access
00 hex	UNSIGNED8	Number Of Entries	02 hex	RO
01 hex	UNSIGNED8	Project CRC, low byte	00 hex	RO
02 hex	UNSIGNED8	Project CRC, high byte	00 hex	RO

Vendor Specific Object Index 2101 hex – Fieldbus Inputs

Object Type: Array of UNSIGNED8

Subindex	Type	Usage/Name	Default value	Access
00 hex	UNSIGNED8	Number Of Entries	04 hex	RO
01 hex	UNSIGNED8	Fieldbus inputs byte 0	00 hex	RW
02 hex	UNSIGNED8	Fieldbus inputs byte 1	00 hex	RW
03 hex	UNSIGNED8	Fieldbus inputs byte 2	00 hex	RW
04 hex	UNSIGNED8	Fieldbus inputs byte 3	00 hex	RW

Vendor Specific Object Index 2181 hex – Fieldbus Inputs Feedback

Object Type: Array of UNSIGNED8

Subindex	Type	Usage/Name	Default value	Access
00 hex	UNSIGNED8	Number Of Entries	04 hex	RO
01 hex	UNSIGNED8	Fieldbus inputs feedback byte 0	00 hex	RW
02 hex	UNSIGNED8	Fieldbus inputs feedback byte 1	00 hex	RW
03 hex	UNSIGNED8	Fieldbus inputs feedback byte 2	00 hex	RW
04 hex	UNSIGNED8	Fieldbus inputs feedback byte 3	00 hex	RW

Vendor Specific Object Index 2201 hex – Input Status

Object Type: Array of UNSIGNED8

Subindex	Type	Usage/Name	Default value	Access
00 hex	UNSIGNED8	Number Of Entries	10 hex	RO
01 hex	UNSIGNED8	Input status byte 0	00 hex	RO
02 hex	UNSIGNED8	Input status byte 1	00 hex	RO
03 hex	UNSIGNED8	Input status byte 2	00 hex	RO
04 hex	UNSIGNED8	Input status byte 3	00 hex	RO
05 hex	UNSIGNED8	Input status byte 4	00 hex	RO
06 hex	UNSIGNED8	Input status byte 5	00 hex	RO
07 hex	UNSIGNED8	Input status byte 6	00 hex	RO
08 hex	UNSIGNED8	Input status byte 7	00 hex	RO
09 hex	UNSIGNED8	Input status byte 8	00 hex	RO

Subindex	Type	Usage/Name	Default value	Access
0A hex	UNSIGNED8	Input status byte 9	00 hex	RO
0B hex	UNSIGNED8	Input status byte 10	00 hex	RO
0C hex	UNSIGNED8	Input status byte 11	00 hex	RO
0D hex	UNSIGNED8	Input status byte 12	00 hex	RO
0E hex	UNSIGNED8	Input status byte 13	00 hex	RO
0F hex	UNSIGNED8	Input status byte 14	00 hex	RO
10 hex	UNSIGNED8	Input status byte 15	00 hex	RO

Vendor Specific Object Index 2202 hex – Safety-related Output Status

Object Type: Array of UNSIGNED8

Subindex	Type	Usage/Name	Default value	Access
00 hex	UNSIGNED8	Number Of Entries	04 hex	RO
01 hex	UNSIGNED8	Safety-related Output status byte 0	00 hex	RO
02 hex	UNSIGNED8	Safety-related Output status byte 1	00 hex	RO
03 hex	UNSIGNED8	Safety-related Output status byte 2	00 hex	RO
04 hex	UNSIGNED8	Safety-related Output status byte 3	00 hex	RO

Vendor Specific Object Index 2203 hex – Probe status

Object Type: Array of UNSIGNED8

Subindex	Type	Usage/Name	Default value	Access
00 hex	UNSIGNED8	Number Of Entries	04 hex	RO
01 hex	UNSIGNED8	Probe status byte 0	00 hex	RO
02 hex	UNSIGNED8	Probe status byte 1	00 hex	RO
03 hex	UNSIGNED8	Probe status byte 2	00 hex	RO
04 hex	UNSIGNED8	Probe status byte 3	00 hex	RO

Vendor Specific Object Index 2204 hex – Analog data

Object Type: Array of REAL32

Subindex	Type	Usage/Name	Default value	Access
00 hex	UNSIGNED8	Number Of Entries	10 hex	RO
01 hex	REAL32	Analog data float 0	0.0f	RO
02 hex	REAL32	Analog data float 1	0.0f	RO
03 hex	REAL32	Analog data float 2	0.0f	RO
04 hex	REAL32	Analog data float 3	0.0f	RO
05 hex	REAL32	Analog data float 4	0.0f	RO
06 hex	REAL32	Analog data float 5	0.0f	RO
07 hex	REAL32	Analog data float 6	0.0f	RO
08 hex	REAL32	Analog data float 7	0.0f	RO
09 hex	REAL32	Analog data float 8	0.0f	RO
0A hex	REAL32	Analog data float 9	0.0f	RO
0B hex	REAL32	Analog data float 10	0.0f	RO
0C hex	REAL32	Analog data float 11	0.0f	RO
0D hex	REAL32	Analog data float 12	0.0f	RO
0E hex	REAL32	Analog data float 13	0.0f	RO
0F hex	REAL32	Analog data float 14	0.0f	RO
10 hex	REAL32	Analog data float 15	0.0f	RO

Acyclic Data Access

The data of the XPSMCMCO0000EC• can be accessed acyclically via SDO (service data object) access of CoE (CANopen over EtherCAT). The addressing schema uses indexes and sub-indexes.

The listed vendor specific objects are available to acyclic access.

XPSMCMCO0000EI• EtherNet/IP

LED Indicators

The **PWR**, **RUN**, **E IN** and **E EX** LED indicators are present on the module, they are described in the sections Common LEDs for Operation (*see page 21*) and in Common LED Indicators for Troubleshooting (*see page 22*).

The following table presents the LED indicator **EIP NS**:

State	Indication
OFF	No power or no IP address.
Steady green	Online, connected. One or more connections established (CIP Class 1 or 3).
Green flashing	Online, not connected.
Steady red	Duplicate IP address.
Red flashing	Connection timeout, one or more connections timed out (CIP class 1 or 3).

The following table presents the LED indicator **MS**:

State	Indication
OFF	No power.
Steady green	Operating state Operational.
Green flashing	Not configured or Scanner is idle.
Steady red	One or more non-recoverable errors detected.
Red flashing	One or more recoverable errors detected.
Operating states mentioned in the table according to the EtherNet/IP state machine	

Connector Details

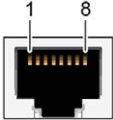
Module-specific characteristics	XPSMCMCO0000E1•
Reference description	EIP: EtherNet/IP non-safety-related fieldbus module.
Output and PIN number	RJ45 - female 
Wiring	Pin/ Signal 1/ Tx+ 2/ Tx- 3/ Rx+ 4/ not connected 5/ not connected 6/ Rx- 7/ not connected 8/ not connected
Baudrate	10/100 Mbit (full/half duplex)

XPSMCMCO0000EI• EtherNet/IP - Mapping Information

Device Identification

Item	Value	Remarks
Vendor ID	243	Vendor ID for Schneider Electric SE
Product Code	4101	Product code for the XPSMCM Ethernet/IP module
Major Revision	21	Reflects the firmware version of the device
Minor Revision	1	Reflects the firmware version of the device
Vendor Name	'Schneider Electric'	-
Product Name	'XPSMCM EtherNet/IP Fieldb. exp.'	-
Product Type	12	= 'Communications Adapter'
Catalog Number	'XPSMCMCO0000EI'	-
Device icon		Provided as a separate icon file 'Preventa_XPSMCM.ico' alongside the device description

Cyclic Data Access

EtherNet/IP uses two assembly object instances to transport process data:

- Assembly object 96 hex for consumed data
- Assembly object 64 hex for produced data

Each of these assembly objects contains several attributes that represent individual process data items.

Assembly Object 96 hex (Consuming Instance)

Byte offset	Size	Name	Default value	Access
0	USINT	Fieldbus input byte 0	00 hex	RW
1	USINT	Fieldbus input byte 1	00 hex	RW
2	USINT	Fieldbus input byte 2	00 hex	RW
3	USINT	Fieldbus input byte 3	00 hex	RW

Assembly Object 64 hex (Producing Instance)

Byte offset	Size	Name	Default value	Access
0	USINT	System status	00 hex	RO
1	USINT	Reserved	00 hex	RO

Byte offset	Size	Name	Default value	Access
2	USINT	Input status byte 0	00 hex	RO
3	USINT	Input status byte 1	00 hex	RO
4	USINT	Input status byte 2	00 hex	RO
5	USINT	Input status byte 3	00 hex	RO
6	USINT	Input status byte 4	00 hex	RO
7	USINT	Input status byte 5	00 hex	RO
8	USINT	Input status byte 6	00 hex	RO
9	USINT	Input status byte 7	00 hex	RO
10	USINT	Input status byte 8	00 hex	RO
11	USINT	Input status byte 9	00 hex	RO
12	USINT	Input status byte 10	00 hex	RO
13	USINT	Input status byte 11	00 hex	RO
14	USINT	Input status byte 12	00 hex	RO
15	USINT	Input status byte 13	00 hex	RO
16	USINT	Input status byte 14	00 hex	RO
17	USINT	Input status byte 15	00 hex	RO
18	USINT	Fieldbus input byte 0 feedback	00 hex	RO
19	USINT	Fieldbus input byte 1 feedback	00 hex	RO
20	USINT	Fieldbus input byte 2 feedback	00 hex	RO
21	USINT	Fieldbus input byte 3 feedback	00 hex	RO
22	USINT	Probe status byte 0	00 hex	RO
23	USINT	Probe status byte 1	00 hex	RO
24	USINT	Probe status byte 2	00 hex	RO
25	USINT	Probe status byte 3	00 hex	RO
26	USINT	Safety-related Output status byte 0	00 hex	RO
27	USINT	Safety-related Output status byte 1	00 hex	RO
28	USINT	Safety-related Output status byte 2	00 hex	RO
29	USINT	Safety-related Output status byte 3	00 hex	RO
30	REAL	Analog data float 0	0.0 f	RO
34	REAL	Analog data float 1	0.0 f	RO
38	REAL	Analog data float 2	0.0 f	RO
42	REAL	Analog data float 3	0.0 f	RO
46	REAL	Analog data float 4	0.0 f	RO
50	REAL	Analog data float 5	0.0 f	RO

Byte offset	Size	Name	Default value	Access
54	REAL	Analog data float 6	0.0 f	RO
58	REAL	Analog data float 7	0.0 f	RO
62	REAL	Analog data float 8	0.0 f	RO
66	REAL	Analog data float 9	0.0 f	RO
70	REAL	Analog data float 10	0.0 f	RO
74	REAL	Analog data float 11	0.0 f	RO
78	REAL	Analog data float 12	0.0 f	RO
82	REAL	Analog data float 13	0.0 f	RO
86	REAL	Analog data float 14	0.0 f	RO
90	REAL	Analog data float 15	0.0 f	RO

USINT: 1 byte; REAL: 4 byte

Acyclic Data Access

Use the service 0x0E (get attribute single) to access the errors data, input diagnostics, OSSD diagnostics and project CRC.

Name	Class	Instance	Attribute	Length (byte)	Access type
Fieldbus Inputs	A2 hex	101 hex	05 hex	4	Set/Get
System I/O	A2 hex	01 hex	05 hex	30	Get
Analog data	A2 hex	204 hex	05 hex	64	Get
Errors data CPU 0	A2 hex	03 hex	05 hex	9	Get
Errors data CPU 1	A2 hex	04 hex	05 hex	9	Get
Input diagnostics	A2 hex	05 hex	05 hex	32	Get
Safety-Related Output Diagnostics	A2 hex	06 hex	05 hex	32	Get
Project CRC	A2 hex	07 hex	05 hex	2	Get

Fieldbus Inputs

The inner structure of this item follows the same schema as for the cyclic data access.

Byte offset	Size	Name	Default value	Access
0	USINT	Fieldbus input byte 0	00 hex	Get/Set
1	USINT	Fieldbus input byte 1	00 hex	Get/Set
2	USINT	Fieldbus input byte 2	00 hex	Get/Set
3	USINT	Fieldbus input byte 3	00 hex	Get/Set

System I/O

This item aggregates the data that is usually transferred as cyclic input data except the analog data, for example Input Status, Safety-related Output status, etc. The inner structure of this item follows the same schema as for the cyclic data access.

Byte offset	Size	Name	Default value	Access
0	USINT	System status	00 hex	Get
1	USINT	Reserved	00 hex	Get
2	USINT	Input status byte 0	00 hex	Get
3	USINT	Input status byte 1	00 hex	Get
4	USINT	Input status byte 2	00 hex	Get
5	USINT	Input status byte 3	00 hex	Get
6	USINT	Input status byte 4	00 hex	Get
7	USINT	Input status byte 5	00 hex	Get
8	USINT	Input status byte 6	00 hex	Get
9	USINT	Input status byte 7	00 hex	Get
10	USINT	Input status byte 8	00 hex	Get
11	USINT	Input status byte 9	00 hex	Get
12	USINT	Input status byte 10	00 hex	Get
13	USINT	Input status byte 11	00 hex	Get
14	USINT	Input status byte 12	00 hex	Get
15	USINT	Input status byte 13	00 hex	Get
16	USINT	Input status byte 14	00 hex	Get
17	USINT	Input status byte 15	00 hex	Get
18	USINT	Fieldbus input byte 0 feedback	00 hex	Get
19	USINT	Fieldbus input byte 1 feedback	00 hex	Get
20	USINT	Fieldbus input byte 2 feedback	00 hex	Get
21	USINT	Fieldbus input byte 3 feedback	00 hex	Get
22	USINT	Probe status byte 0	00 hex	Get
23	USINT	Probe status byte 1	00 hex	Get
24	USINT	Probe status byte 2	00 hex	Get
25	USINT	Probe status byte 3	00 hex	Get
26	USINT	Safety-related Output status byte 0	00 hex	Get
27	USINT	Safety-related Output status byte 1	00 hex	Get
28	USINT	Safety-related Output status byte 2	00 hex	Get
29	USINT	Safety-related Output status byte 3	00 hex	Get

Analog Data

The inner structure of this item follows the same schema as for the cyclic data access.

Byte offset	Size	Name	Default value	Access
0-3	REAL	Analog data float 0	0.0 f	Get
4-7	REAL	Analog data float 1	0.0 f	Get
8-11	REAL	Analog data float 2	0.0 f	Get
12-15	REAL	Analog data float 3	0.0 f	Get
16-19	REAL	Analog data float 4	0.0 f	Get
20-23	REAL	Analog data float 5	0.0 f	Get
24-27	REAL	Analog data float 6	0.0 f	Get
28-31	REAL	Analog data float 7	0.0 f	Get
32-35	REAL	Analog data float 8	0.0 f	Get
36-39	REAL	Analog data float 9	0.0 f	Get
40-43	REAL	Analog data float 10	0.0 f	Get
44-47	REAL	Analog data float 11	0.0 f	Get
48-51	REAL	Analog data float 12	0.0 f	Get
52-55	REAL	Analog data float 13	0.0 f	Get
56-59	REAL	Analog data float 14	0.0 f	Get
60-63	REAL	Analog data float 15	0.0 f	Get

CPU Error Data 0 and 1

The inner structure of these items follows the following schema:

Byte offset	Size	Name	Default value	Access
0	UINT8	Module	00 hex	Get
1	UINT8	Error code	00 hex	Get
2-5	UINT32	Error address	00000000 hex	Get
6	UINT8	CPU firmware version	00 hex	Get
7	UINT8	Extended code 0 (optional)	00 hex	Get
8	UINT8	Extended code 1 (optional)	00 hex	Get

Input & Safety-Related Output Diagnostics

The inner structure of these items follows the following schema:

Byte offset	Size	Name	Default value	Access
0	UINT8	Diagnostic index 0	00 hex	Get
1	UINT8	Diagnostic code 0	00 hex	Get
2	UINT8	Diagnostic index 1	00 hex	Get
3	UINT8	Diagnostic code 1	00 hex	Get
4	UINT8	Diagnostic index 2	00 hex	Get
5	UINT8	Diagnostic code 2	00 hex	Get
6	UINT8	Diagnostic index 3	00 hex	Get
7	UINT8	Diagnostic code 3	00 hex	Get
8	UINT8	Diagnostic index 4	00 hex	Get
9	UINT8	Diagnostic code 4	00 hex	Get
10	UINT8	Diagnostic index 5	00 hex	Get
11	UINT8	Diagnostic code 5	00 hex	Get
12	UINT8	Diagnostic index 6	00 hex	Get
13	UINT8	Diagnostic code 6	00 hex	Get
14	UINT8	Diagnostic index 7	00 hex	Get
15	UINT8	Diagnostic code 7	00 hex	Get
16	UINT8	Diagnostic index 8	00 hex	Get
17	UINT8	Diagnostic code 8	00 hex	Get
18	UINT8	Diagnostic index 9	00 hex	Get
19	UINT8	Diagnostic code 9	00 hex	Get
20	UINT8	Diagnostic index 10	00 hex	Get
21	UINT8	Diagnostic code 10	00 hex	Get
22	UINT8	Diagnostic index 11	00 hex	Get
23	UINT8	Diagnostic code 11	00 hex	Get
24	UINT8	Diagnostic index 12	00 hex	Get
25	UINT8	Diagnostic code 12	00 hex	Get
26	UINT8	Diagnostic index 13	00 hex	Get
27	UINT8	Diagnostic code 13	00 hex	Get
28	UINT8	Diagnostic index 14	00 hex	Get
29	UINT8	Diagnostic code 14	00 hex	Get
30	UINT8	Diagnostic index 15	00 hex	Get
31	UINT8	Diagnostic code 15	00 hex	Get

Project CRC

The inner structure of these items follows the following schema:

Byte offset	Size	Name	Default value	Access
0	UINT8	Project CRC – low byte	00 hex	Get
1	UINT8	Project CRC – high byte	00 hex	Get

XPSMCMCO0000MB• Modbus

LED Indicators

The **PWR**, **RUN**, **E IN** and **E EX** LED indicators are present on the module, they are described in the sections Common LEDs for Operation (*see page 21*) and in Common LED Indicators for Troubleshooting (*see page 22*).

The following table presents the LED indicator **MBS COM**:

State	Indication
OFF	No power or no data exchange.
Yellow	Frame reception or transmission.
Steady red	One or more non-recoverable errors detected.

The following table presents the LED indicator **STS**:

State	Indication
OFF	No power or initializing.
Steady green	Module initialized.
Steady red	One or more non-recoverable errors detected.
Periodic single red flash	Communication or configuration error detected.
Periodic double red flash	Application diagnostics available.

Connector Details

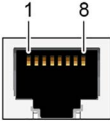
Module-specific characteristics	XPSMCMCO0000MB•
Reference description	MBS (Modbus Serial) standard fieldbus module.
Output and PIN number	RJ45 - female 
Wiring	Pin/ Signal 1/ not connected 2/ not connected 3/ not connected 4/ D1 5/ D0 6/ not connected 7/ VP (5 Vdc supply) 8/ Common Housing/cable shield
Baudrate	Up to 115200 bps

XPSMCMCO0000MB• Modbus RTU - Mapping Information

Device Identification

The Modbus device provides its device identification information via the function code “Read Device Identification”, which is a sub-function of the function “Encapsulated Interface Transport”.

The objects provided on this interface are grouped into three categories:

- Basic (mandatory)
- Regular (optional)
- Extended (manufacturer/device specific, optional)

Object IDs for usage in function 43 (2B hex), sub-function 14 (0E hex): “Read Device Identification”

Item	Value	Object ID	Category	Remarks
Vendor Name	'Schneider Electric'	00 hex	Basic	-
Product Code	'XPSMCMCO0000MB'	01 hex	Basic	-
Major Minor Revision	'2.1.1'	02 hex	Basic	Reflects the Firmware version of the device
Vendor URL	'www.schneider-electric.com'	03 hex	Regular	Vendor ID for Schneider Electric SE
Product Name	'Modbus (RTU) communication unit'	04 hex	Regular	-
Model Name	'XPSMCM communication unit'	05 hex	Regular	-
User Application Name	-	06 hex	Regular	-

Cyclic Data Access

For Modbus there is no intrinsic cyclic data communication protocol. Instead, if a periodic update of some registers is required, the Modbus Client (e.g. logic controller) periodically polls the required information from the Server (e.g. IO device, XPSMCMCO0000CO• module) using the appropriate function codes (refer to Acyclic Data Access ([see page 67](#))).

The register mapping and the supported function codes for the XPSMCMCO0000• Modbus serial communication module are described in the following chapter Acyclic Data Access ([see page 67](#)).

Acyclic Data Access - Holding Registers (4x)

Register number	Register offset	Byte	Size	Usage/Name	Default value	Access
40001	0000 hex	low	UINT8	Fieldbus input byte 0	00 hex	RW
		high	UINT8	Fieldbus input byte 1	00 hex	RW
40002	0001 hex	low	UINT8	Fieldbus input byte 2	00 hex	RW
		high	UINT8	Fieldbus input byte 3	00 hex	RW

Register number	Register offset	Byte	Size	Usage/Name	Default value	Access
40257	0100 hex	low	UINT8	System status	00 hex	RO
		high	UINT8	Reserved	00 hex	RO
40258	0101 hex	low	UINT8	Input status byte 0	00 hex	RO
		high	UINT8	Input status byte 1	00 hex	RO
40259	0102 hex	low	UINT8	Input status byte 2	00 hex	RO
		high	UINT8	Input status byte 3	00 hex	RO
40260	0103 hex	low	UINT8	Input status byte 4	00 hex	RO
		high	UINT8	Input status byte 5	00 hex	RO
40261	0104 hex	low	UINT8	Input status byte 6	00 hex	RO
		high	UINT8	Input status byte 7	00 hex	RO
40262	0105 hex	low	UINT8	Input status byte 8	00 hex	RO
		high	UINT8	Input status byte 9	00 hex	RO
40263	0106 hex	low	UINT8	Input status byte 10	00 hex	RO
		high	UINT8	Input status byte 11	00 hex	RO
40264	0107 hex	low	UINT8	Input status byte 12	00 hex	RO
		high	UINT8	Input status byte 13	00 hex	RO
40265	0108 hex	low	UINT8	Input status byte 14	00 hex	RO
		high	UINT8	Input status byte 15	00 hex	RO
40266	0109 hex	low	UINT8	Fieldbus input feedback byte 0	00 hex	RO
		high	UINT8	Fieldbus input feedback byte 1	00 hex	RO
40267	010A hex	low	UINT8	Fieldbus input feedback byte 2	00 hex	RO
		high	UINT8	Fieldbus input feedback byte 3	00 hex	RO
40268	010B hex	low	UINT8	Probe status byte 0	00 hex	RO
		high	UINT8	Probe status byte 1	00 hex	RO
40269	010C hex	low	UINT8	Probe status byte 2	00 hex	RO
		high	UINT8	Probe status byte 3	00 hex	RO
40270	010D hex	low	UINT8	Safety-related Output status byte 0	00 hex	RO
		high	UINT8	Safety-related Output status byte 1	00 hex	RO
40271	010E hex	low	UINT8	Safety-related Output status byte 2	00 hex	RO
		high	UINT8	Safety-related Output status byte 3	00 hex	RO

Register number	Register offset	Byte	Size	Usage/Name	Default value	Access
40272	010F hex	low	FLOAT	Analog data float 0	0.0f	RO
		high				
40273	0110 hex	low				
		high				
40274	0111 hex	low	FLOAT	Analog data float 1	0.0f	RO
		high				
40275	0112 hex	low				
		high				
40276	0113 hex	low	FLOAT	Analog data float 2	0.0f	RO
		high				
40277	0114 hex	low				
		high				
40278	0115 hex	low	FLOAT	Analog data float 3	0.0f	RO
		high				
40279	0116 hex	low				
		high				
40280	0117 hex	low	FLOAT	Analog data float 4	0.0f	RO
		high				
40281	0118 hex	low				
		high				
40282	0119 hex	low	FLOAT	Analog data float 5	0.0f	RO
		high				
40283	011A hex	low				
		high				
40284	011B hex	low	FLOAT	Analog data float 6	0.0f	RO
		high				
40285	011C hex	low				
		high				
40286	011D hex	low	FLOAT	Analog data float 7	0.0f	RO
		high				
40287	011E hex	low				
		high				

Register number	Register offset	Byte	Size	Usage/Name	Default value	Access
40288	011F hex	low	FLOAT	Analog data float 8	0.0f	RO
		high				
40289	0120 hex	low				
		high				
40290	0121 hex	low	FLOAT	Analog data float 9	0.0f	RO
		high				
40291	0122 hex	low				
		high				
40292	0123 hex	low	FLOAT	Analog data float 10	0.0f	RO
		high				
40293	0124 hex	low				
		high				
40294	0125 hex	low	FLOAT	Analog data float 11	0.0f	RO
		high				
40295	0126 hex	low				
		high				
40296	0127 hex	low	FLOAT	Analog data float 12	0.0f	RO
		high				
40297	0128 hex	low				
		high				
40298	0129 hex	low	FLOAT	Analog data float 13	0.0f	RO
		high				
40299	012A hex	low				
		high				
40300	012B hex	low	FLOAT	Analog data float 14	0.0f	RO
		high				
40301	012C hex	low				
		high				
40302	012D hex	low	FLOAT	Analog data float 15	0.0f	RO
		high				
40303	012E hex	low				
		high				

Register number	Register offset	Byte	Size	Usage/Name	Default value	Access
40561	0230 hex	low	UINT8	Error CPU0 – Module	00 hex	RO
		high	UINT8	Error CPU0 – Error code	00 hex	RO
40562	0231 hex	low	UINT32	Error CPU0 – Error address	00000000 hex	RO
		high				
40563	0232 hex	low				
		high				
40564	0233 hex	low	UINT8	Error CPU0 – Firmware version	00 hex	RO
		high	UINT8	Error CPU0 – Extended code 0	00 hex	RO
40565	0234 hex	low	UINT8	Error CPU0 – Extended code 1	00 hex	RO
		high	UINT8	Reserved	00 hex	RO

Register number	Register offset	Byte	Size	Usage/Name	Default value	Access
40577	0240 hex	low	UINT8	Error CPU1 – Module	00 hex	RO
		high	UINT8	Error CPU1 – Error code	00 hex	RO
40578	0241 hex	low	UINT32	Error CPU1 – Error address	00000000 hex	RO
		high				
40579	0242 hex	low				
		high				
40580	0243 hex	low	UINT8	Error CPU1 – Firmware version	00 hex	RO
		high	UINT8	Error CPU1 – Extended code 0	00 hex	RO
40581	0244 hex	low	UINT8	Error CPU1 – Extended code 1	00 hex	RO
		high	UINT8	Reserved	00 hex	RO

Register number	Register offset	Byte	Size	Usage/Name	Default value	Access
40593	0250 hex	low	UINT8	Input diagnostics index 1	00 hex	RO
		high	UINT8	Input diagnostics code 1	00 hex	RO
40594	0251 hex	low	UINT8	Input diagnostics index 2	00 hex	RO
		high	UINT8	Input diagnostics code 2	00 hex	RO
40595	0252 hex	low	UINT8	Input diagnostics index 3	00 hex	RO
		high	UINT8	Input diagnostics code 3	00 hex	RO

Register number	Register offset	Byte	Size	Usage/Name	Default value	Access
40596	0253 hex	low	UINT8	Input diagnostics index 4	00 hex	RO
		high	UINT8	Input diagnostics code 4	00 hex	RO
40597	0254 hex	low	UINT8	Input diagnostics index 5	00 hex	RO
		high	UINT8	Input diagnostics code 5	00 hex	RO
40598	0255 hex	low	UINT8	Input diagnostics index 6	00 hex	RO
		high	UINT8	Input diagnostics code 6	00 hex	RO
40599	0256 hex	low	UINT8	Input diagnostics index 7	00 hex	RO
		high	UINT8	Input diagnostics code 7	00 hex	RO
40600	0257 hex	low	UINT8	Input diagnostics index 8	00 hex	RO
		high	UINT8	Input diagnostics code 8	00 hex	RO
40601	0258 hex	low	UINT8	Input diagnostics index 9	00 hex	RO
		high	UINT8	Input diagnostics code 9	00 hex	RO
40602	0259 hex	low	UINT8	Input diagnostics index 10	00 hex	RO
		high	UINT8	Input diagnostics code 10	00 hex	RO
40603	025A hex	low	UINT8	Input diagnostics index 11	00 hex	RO
		high	UINT8	Input diagnostics code 11	00 hex	RO
40604	025B hex	low	UINT8	Input diagnostics index 12	00 hex	RO
		high	UINT8	Input diagnostics code 12	00 hex	RO
40605	025C hex	low	UINT8	Input diagnostics index 13	00 hex	RO
		high	UINT8	Input diagnostics code 13	00 hex	RO
40606	025D hex	low	UINT8	Input diagnostics index 14	00 hex	RO
		high	UINT8	Input diagnostics code 14	00 hex	RO
40607	025E hex	low	UINT8	Input diagnostics index 15	00 hex	RO
		high	UINT8	Input diagnostics code 15	00 hex	RO
40608	025F hex	low	UINT8	Input diagnostics index 16	00 hex	RO
		high	UINT8	Input diagnostics code 16	00 hex	RO
40609	0260 hex	low	UINT8	Output diagnostics index 1	00 hex	RO
		high	UINT8	Output diagnostics code 1	00 hex	RO
40610	0261 hex	low	UINT8	Output diagnostics index 2	00 hex	RO
		high	UINT8	Output diagnostics code 2	00 hex	RO
40611	0262 hex	low	UINT8	Output diagnostics index 3	00 hex	RO
		high	UINT8	Output diagnostics code 3	00 hex	RO
40612	0263 hex	low	UINT8	Output diagnostics index 4	00 hex	RO
		high	UINT8	Output diagnostics code 4	00 hex	RO

Register number	Register offset	Byte	Size	Usage/Name	Default value	Access
40596	0253 hex	low	UINT8	Input diagnostics index 4	00 hex	RO
		high	UINT8	Input diagnostics code 4	00 hex	RO
40597	0254 hex	low	UINT8	Input diagnostics index 5	00 hex	RO
		high	UINT8	Input diagnostics code 5	00 hex	RO
40598	0255 hex	low	UINT8	Input diagnostics index 6	00 hex	RO
		high	UINT8	Input diagnostics code 6	00 hex	RO
40599	0256 hex	low	UINT8	Input diagnostics index 7	00 hex	RO
		high	UINT8	Input diagnostics code 7	00 hex	RO
40600	0257 hex	low	UINT8	Input diagnostics index 8	00 hex	RO
		high	UINT8	Input diagnostics code 8	00 hex	RO
40601	0258 hex	low	UINT8	Input diagnostics index 9	00 hex	RO
		high	UINT8	Input diagnostics code 9	00 hex	RO
40602	0259 hex	low	UINT8	Input diagnostics index 10	00 hex	RO
		high	UINT8	Input diagnostics code 10	00 hex	RO
40603	025A hex	low	UINT8	Input diagnostics index 11	00 hex	RO
		high	UINT8	Input diagnostics code 11	00 hex	RO
40604	025B hex	low	UINT8	Input diagnostics index 12	00 hex	RO
		high	UINT8	Input diagnostics code 12	00 hex	RO
40605	025C hex	low	UINT8	Input diagnostics index 13	00 hex	RO
		high	UINT8	Input diagnostics code 13	00 hex	RO
40606	025D hex	low	UINT8	Input diagnostics index 14	00 hex	RO
		high	UINT8	Input diagnostics code 14	00 hex	RO
40607	025E hex	low	UINT8	Input diagnostics index 15	00 hex	RO
		high	UINT8	Input diagnostics code 15	00 hex	RO
40608	025F hex	low	UINT8	Input diagnostics index 16	00 hex	RO
		high	UINT8	Input diagnostics code 16	00 hex	RO
40609	0260 hex	low	UINT8	Output diagnostics index 1	00 hex	RO
		high	UINT8	Output diagnostics code 1	00 hex	RO
40610	0261 hex	low	UINT8	Output diagnostics index 2	00 hex	RO
		high	UINT8	Output diagnostics code 2	00 hex	RO
40611	0262 hex	low	UINT8	Output diagnostics index 3	00 hex	RO
		high	UINT8	Output diagnostics code 3	00 hex	RO
40612	0263 hex	low	UINT8	Output diagnostics index 4	00 hex	RO
		high	UINT8	Output diagnostics code 4	00 hex	RO

Register number	Register offset	Byte	Size	Usage/Name	Default value	Access
40613	0264 hex	low	UINT8	Output diagnostics index 5	00 hex	RO
		high	UINT8	Output diagnostics code 5	00 hex	RO
40614	0265 hex	low	UINT8	Output diagnostics index 6	00 hex	RO
		high	UINT8	Output diagnostics code 6	00 hex	RO
40615	0266 hex	low	UINT8	Output diagnostics index 7	00 hex	RO
		high	UINT8	Output diagnostics code 7	00 hex	RO
40616	0267 hex	low	UINT8	Output diagnostics index 8	00 hex	RO
		high	UINT8	Output diagnostics code 8	00 hex	RO
40617	0268 hex	low	UINT8	Output diagnostics index 9	00 hex	RO
		high	UINT8	Output diagnostics code 9	00 hex	RO
40618	0269 hex	low	UINT8	Output diagnostics index 10	00 hex	RO
		high	UINT8	Output diagnostics code 10	00 hex	RO
40619	026A hex	low	UINT8	Output diagnostics index 11	00 hex	RO
		high	UINT8	Output diagnostics code 11	00 hex	RO
40620	026B hex	low	UINT8	Output diagnostics index 12	00 hex	RO
		high	UINT8	Output diagnostics code 12	00 hex	RO
40621	026C hex	low	UINT8	Output diagnostics index 13	00 hex	RO
		high	UINT8	Output diagnostics code 13	00 hex	RO
40622	026D hex	low	UINT8	Output diagnostics index 14	00 hex	RO
		high	UINT8	Output diagnostics code 14	00 hex	RO
40623	026E hex	low	UINT8	Output diagnostics index 15	00 hex	RO
		high	UINT8	Output diagnostics code 15	00 hex	RO
40624	026F hex	low	UINT8	Output diagnostics index 16	00 hex	RO
		high	UINT8	Output diagnostics code 16	00 hex	RO
40625	0270 hex	low	UINT8	Project CRC, low byte	00 hex	RO
		high	UINT8	Project CRC, high byte	00 hex	RO

XPSMCMCO0000EM• Modbus TCP

LED Indicators

The **PWR**, **RUN**, **E IN** and **E EX** LED indicators are present on the module, they are described in the sections Common LEDs for Operation (*see page 21*) and in Common LED Indicators for Troubleshooting (*see page 22*).

The following table presents the LED indicator **MTP NET**:

State	Indication
OFF	No power or no IP address.
Steady green	Online, connected.
Flashes green	Online, not connected.
Steady red	Duplicate IP address.
Flashes red	Connection timeout.

The following table presents the LED indicator **STS**:

State	Indication
OFF	No power.
Steady green	Running.
Flashes green	Not configured.
Steady red	One or more non-recoverable errors detected.
Flashes red	One or more recoverable errors detected.

Connector Details

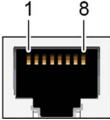
Module-specific characteristics	XPSMCMCO0000EM•
Reference description	MTP (Modbus TCP/IP) standard fieldbus module
Output and PIN number	RJ45 - female 
Wiring	Pin/ Signal 1/ Tx+ 2/ Tx- 3/ Rx+ 4/ not connected 5/ not connected 6/ Rx- 7/ not connected 8/ not connected
Baudrate	10/100 Mbit (full/half duplex)

XPSMCMCO0000EM• Modbus TCP - Mapping Information

Device Identification

The Modbus device provides its device identification information via the function code “Read Device Identification”, which is a sub-function of the function “Encapsulated Interface Transport”.

The objects provided on this interface are grouped into three categories:

- Basic (mandatory)
- Regular (optional)
- Extended (manufacturer/device specific, optional)

Object IDs for usage in function 43 (2B hex), sub-function 14 (0E hex): “Read Device Identification”

Item	Value	Object ID	Category	Remarks
Vendor Name	'Schneider Electric'	00 hex	Basic	-
Product Code	'XPSMCMCO0000EM'	01 hex	Basic	-
Major Minor Revision	'2.1.1'	02 hex	Basic	Reflects the firmware version of the device
Vendor URL	'www.schneider-electric.com'	03 hex	Regular	Vendor ID for Schneider Electric SE
Product Name	'ModBus(TCP) communication unit'	04 hex	Regular	-
Model Name	'XPSMCM communication unit'	05 hex	Regular	-
User Application Name	-	06 hex	Regular	-

Cyclic Data Access

For Modbus in general, there is no intrinsic cyclic data communication protocol. Instead, if a periodic update of some registers is required, the Modbus Client (e.g. logic controller) periodically polls the required information from the Server (e.g. IO device, XPSMCMCO0000• module) using the appropriate function codes (see "Acyclic Data Access" below).

The register mapping and the supported function codes for the XPSMCMCO0000• Modbus TCP/IP communication module are described in the following chapter "Acyclic Data Access".

Acyclic Data Access - Holding Registers (4x)

Register number	Register offset	Byte	Size	Usage/Name	Default value	Access
40001	0000 hex	low	UINT8	Fieldbus input byte 0	00 hex	RW
		high	UINT8	Fieldbus input byte 1	00 hex	RW
40002	0001 hex	low	UINT8	Fieldbus input byte 2	00 hex	RW
		high	UINT8	Fieldbus input byte 3	00 hex	RW

Register number	Register offset	Byte	Size	Usage/Name	Default value	Access
40257	0100 hex	low	UINT8	System status	00 hex	RO
		high	UINT8	Reserved	00 hex	RO
40258	0101 hex	low	UINT8	Input status byte 0	00 hex	RO
		high	UINT8	Input status byte 1	00 hex	RO
40259	0102 hex	low	UINT8	Input status byte 2	00 hex	RO
		high	UINT8	Input status byte 3	00 hex	RO
40260	0103 hex	low	UINT8	Input status byte 4	00 hex	RO
		high	UINT8	Input status byte 5	00 hex	RO
40261	0104 hex	low	UINT8	Input status byte 6	00 hex	RO
		high	UINT8	Input status byte 7	00 hex	RO
40262	0105 hex	low	UINT8	Input status byte 8	00 hex	RO
		high	UINT8	Input status byte 9	00 hex	RO
40263	0106 hex	low	UINT8	Input status byte 10	00 hex	RO
		high	UINT8	Input status byte 11	00 hex	RO
40264	0107 hex	low	UINT8	Input status byte 12	00 hex	RO
		high	UINT8	Input status byte 13	00 hex	RO
40265	0108 hex	low	UINT8	Input status byte 14	00 hex	RO
		high	UINT8	Input status byte 15	00 hex	RO
40266	0109 hex	low	UINT8	Fieldbus input feedback byte 0	00 hex	RO
		high	UINT8	Fieldbus input feedback byte 1	00 hex	RO
40267	010A hex	low	UINT8	Fieldbus input feedback byte 2	00 hex	RO
		high	UINT8	Fieldbus input feedback byte 3	00 hex	RO
40268	010B hex	low	UINT8	Probe status byte 0	00 hex	RO
		high	UINT8	Probe status byte 1	00 hex	RO
40269	010C hex	low	UINT8	Probe status byte 2	00 hex	RO
		high	UINT8	Probe status byte 3	00 hex	RO
40270	010D hex	low	UINT8	Safety-related Output status byte 0	00 hex	RO
		high	UINT8	Safety-related Output status byte 1	00 hex	RO
40271	010E hex	low	UINT8	Safety-related Output status byte 2	00 hex	RO
		high	UINT8	Safety-related Output status byte 3	00 hex	RO

Register number	Register offset	Byte	Size	Usage/Name	Default value	Access
40272	010F hex	low	FLOAT	Analog data float 0	0.0f	RO
		high				
40273	0110 hex	low				
		high				
40274	0111 hex	low	FLOAT	Analog data float 1	0.0f	RO
		high				
40275	0112 hex	low				
		high				
40276	0113 hex	low	FLOAT	Analog data float 2	0.0f	RO
		high				
40277	0114 hex	low				
		high				
40278	0115 hex	low	FLOAT	Analog data float 3	0.0f	RO
		high				
40279	0116 hex	low				
		high				
40280	0117 hex	low	FLOAT	Analog data float 4	0.0f	RO
		high				
40281	0118 hex	low				
		high				
40282	0119 hex	low	FLOAT	Analog data float 5	0.0f	RO
		high				
40283	011A hex	low				
		high				
40284	011B hex	low	FLOAT	Analog data float 6	0.0f	RO
		high				
40285	011C hex	low				
		high				
40286	011D hex	low	FLOAT	Analog data float 7	0.0f	RO
		high				
40287	011E hex	low				
		high				

Register number	Register offset	Byte	Size	Usage/Name	Default value	Access				
40288	011F hex	low	FLOAT	Analog data float 8	0.0f	RO				
		high								
40289	0120 hex	low								
		high								
40290	0121 hex	low					FLOAT	Analog data float 9	0.0f	RO
		high								
40291	0122 hex	low								
		high								
40292	0123 hex	low	FLOAT	Analog data float 10	0.0f	RO				
		high								
40293	0124 hex	low								
		high								
40294	0125 hex	low					FLOAT	Analog data float 11	0.0f	RO
		high								
40295	0126 hex	low								
		high								
40296	0127 hex	low	FLOAT	Analog data float 12	0.0f	RO				
		high								
40297	0128 hex	low								
		high								
40298	0129 hex	low					FLOAT	Analog data float 13	0.0f	RO
		high								
40299	012A hex	low								
		high								
40300	012B hex	low	FLOAT	Analog data float 14	0.0f	RO				
		high								
40301	012C hex	low								
		high								
40302	012D hex	low					FLOAT	Analog data float 15	0.0f	RO
		high								
40303	012E hex	low								
		high								

Register number	Register offset	Byte	Size	Usage/Name	Default value	Access
40561	0230 hex	low	UINT8	Error CPU0 – Module	00 hex	RO
		high	UINT8	Error CPU0 – Error code	00 hex	RO
40562	0231 hex	low	UINT32	Error CPU0 – Error address	00000000 hex	RO
		high				
40563	0232 hex	low				
		high				
40564	0233 hex	low	UINT8	Error CPU0 – Firmware version	00 hex	RO
		high	UINT8	Error CPU0 – Extended code 0	00 hex	RO
40565	0234 hex	low	UINT8	Error CPU0 – Extended code 1	00 hex	RO
		high	UINT8	Reserved	00 hex	RO

Register number	Register offset	Byte	Size	Usage/Name	Default value	Access
40577	0240 hex	low	UINT8	Error CPU1 – Module	00 hex	RO
		high	UINT8	Error CPU1 – Error code	00 hex	RO
40578	0241 hex	low	UINT32	Error CPU1 – Error address	00000000 hex	RO
		high				
40579	0242 hex	low				
		high				
40580	0243 hex	low	UINT8	Error CPU1 – Firmware version	00 hex	RO
		high	UINT8	Error CPU1 – Extended code 0	00 hex	RO
40581	0244 hex	low	UINT8	Error CPU1 – Extended code 1	00 hex	RO
		high	UINT8	Reserved	00 hex	RO

Register number	Register offset	Byte	Size	Usage/Name	Default value	Access
40593	0250 hex	low	UINT8	Input diagnostics index 1	00 hex	RO
		high	UINT8	Input diagnostics code 1	00 hex	RO
40594	0251 hex	low	UINT8	Input diagnostics index 2	00 hex	RO
		high	UINT8	Input diagnostics code 2	00 hex	RO
40595	0252 hex	low	UINT8	Input diagnostics index 3	00 hex	RO
		high	UINT8	Input diagnostics code 3	00 hex	RO

Register number	Register offset	Byte	Size	Usage/Name	Default value	Access
40596	0253 hex	low	UINT8	Input diagnostics index 4	00 hex	RO
		high	UINT8	Input diagnostics code 4	00 hex	RO
40597	0254 hex	low	UINT8	Input diagnostics index 5	00 hex	RO
		high	UINT8	Input diagnostics code 5	00 hex	RO
40598	0255 hex	low	UINT8	Input diagnostics index 6	00 hex	RO
		high	UINT8	Input diagnostics code 6	00 hex	RO
40599	0256 hex	low	UINT8	Input diagnostics index 7	00 hex	RO
		high	UINT8	Input diagnostics code 7	00 hex	RO
40600	0257 hex	low	UINT8	Input diagnostics index 8	00 hex	RO
		high	UINT8	Input diagnostics code 8	00 hex	RO
40601	0258 hex	low	UINT8	Input diagnostics index 9	00 hex	RO
		high	UINT8	Input diagnostics code 9	00 hex	RO
40602	0259 hex	low	UINT8	Input diagnostics index 10	00 hex	RO
		high	UINT8	Input diagnostics code 10	00 hex	RO
40603	025A hex	low	UINT8	Input diagnostics index 11	00 hex	RO
		high	UINT8	Input diagnostics code 11	00 hex	RO
40604	025B hex	low	UINT8	Input diagnostics index 12	00 hex	RO
		high	UINT8	Input diagnostics code 12	00 hex	RO
40605	025C hex	low	UINT8	Input diagnostics index 13	00 hex	RO
		high	UINT8	Input diagnostics code 13	00 hex	RO
40606	025D hex	low	UINT8	Input diagnostics index 14	00 hex	RO
		high	UINT8	Input diagnostics code 14	00 hex	RO
40607	025E hex	low	UINT8	Input diagnostics index 15	00 hex	RO
		high	UINT8	Input diagnostics code 15	00 hex	RO
40608	025F hex	low	UINT8	Input diagnostics index 16	00 hex	RO
		high	UINT8	Input diagnostics code 16	00 hex	RO
40609	0260 hex	low	UINT8	Output diagnostics index 1	00 hex	RO
		high	UINT8	Output diagnostics code 1	00 hex	RO
40610	0261 hex	low	UINT8	Output diagnostics index 2	00 hex	RO
		high	UINT8	Output diagnostics code 2	00 hex	RO
40611	0262 hex	low	UINT8	Output diagnostics index 3	00 hex	RO
		high	UINT8	Output diagnostics code 3	00 hex	RO
40612	0263 hex	low	UINT8	Output diagnostics index 4	00 hex	RO
		high	UINT8	Output diagnostics code 4	00 hex	RO

Register number	Register offset	Byte	Size	Usage/Name	Default value	Access
40613	0264 hex	low	UINT8	Output diagnostics index 5	00 hex	RO
		high	UINT8	Output diagnostics code 5	00 hex	RO
40614	0265 hex	low	UINT8	Output diagnostics index 6	00 hex	RO
		high	UINT8	Output diagnostics code 6	00 hex	RO
40615	0266 hex	low	UINT8	Output diagnostics index 7	00 hex	RO
		high	UINT8	Output diagnostics code 7	00 hex	RO
40616	0267 hex	low	UINT8	Output diagnostics index 8	00 hex	RO
		high	UINT8	Output diagnostics code 8	00 hex	RO
40617	0268 hex	low	UINT8	Output diagnostics index 9	00 hex	RO
		high	UINT8	Output diagnostics code 9	00 hex	RO
40618	0269 hex	low	UINT8	Output diagnostics index 10	00 hex	RO
		high	UINT8	Output diagnostics code 10	00 hex	RO
40619	026A hex	low	UINT8	Output diagnostics index 11	00 hex	RO
		high	UINT8	Output diagnostics code 11	00 hex	RO
40620	026B hex	low	UINT8	Output diagnostics index 12	00 hex	RO
		high	UINT8	Output diagnostics code 12	00 hex	RO
40621	026C hex	low	UINT8	Output diagnostics index 13	00 hex	RO
		high	UINT8	Output diagnostics code 13	00 hex	RO
40622	026D hex	low	UINT8	Output diagnostics index 14	00 hex	RO
		high	UINT8	Output diagnostics code 14	00 hex	RO
40623	026E hex	low	UINT8	Output diagnostics index 15	00 hex	RO
		high	UINT8	Output diagnostics code 15	00 hex	RO
40624	026F hex	low	UINT8	Output diagnostics index 16	00 hex	RO
		high	UINT8	Output diagnostics code 16	00 hex	RO
40625	0270 hex	low	UINT8	Project CRC, low byte	00 hex	RO
		high	UINT8	Project CRC, high byte	00 hex	RO

XPSMCMCO0000PB• Profibus

LED Indicators

The **PWR**, **RUN**, **E IN** and **E EX** LED indicators are present on the module, they are described in the sections Common LEDs for Operation (*see page 21*) and in Common LED Indicators for Troubleshooting (*see page 22*).

The following table presents the LED indicator **PDP MODE**:

State	Indication
OFF	No power.
Steady green	Online, connected.
Green flashing	Online, clear.
Periodic single red flash	Parameterization error detected.
Periodic double red flash	Profibus DP configuration error detected (configuration data in master or slave incorrect).

The following table presents the LED indicator **STS**:

State	Indication
OFF	Module not initialized.
Green flashing	Diagnostics exchange active with master.
Steady green	Initialized.
Red flashing (1 Hz)	One or more recoverable errors detected.
Steady red	Non-recoverable error detected.

Connector Details

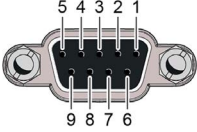
Module-specific characteristics	XPSMCMCO0000PB•
Reference description	PDP (Profibus DP V1) standard fieldbus module.
Output and PIN number	DB9 – female 
Wiring	<p>Pin/ Signal</p> <ul style="list-style-type: none"> 1/ not connected 2/ not connected 3/ B Line / + RxD/TxD, RS485 level 4/ RTS / Request to send 5/ GND Bus/ 0 Vdc (isolated)) 6/ 5 V / +5 V Bus Output / +5 V termination power (isolated, short-circuit protected) 7/ not connected 8/ A Line / - RxD/TxD, RS485 level 9/ not connected <p>Housing/ cable shield / Internally connected to the Anybus protective earth via cable shield filters according to the PROFIBUS standard.</p>
Baudrate	Automatic baud rate detection.

Slot	Size	Dir. ⁽¹⁾	Type-code	Byte offset		Size	Usage/Name	Default value
				Slot	Global			
1	2 bytes	In	0x91 hex	0	0	UINT8	System status	00 hex
				1	1	UINT8	Reserved	00 hex
2	16 bytes	In	0x9F hex	0	2	UINT8	Input status byte 0	00 hex
				1	3	UINT8	Input status byte 1	00 hex
				2	4	UINT8	Input status byte 2	00 hex
				3	5	UINT8	Input status byte 3	00 hex
				4	6	UINT8	Input status byte 4	00 hex
				5	7	UINT8	Input status byte 5	00 hex
				6	8	UINT8	Input status byte 6	00 hex
				7	9	UINT8	Input status byte 7	00 hex
				8	10	UINT8	Input status byte 8	00 hex
				9	11	UINT8	Input status byte 9	00 hex
				10	12	UINT8	Input status byte 10	00 hex
				11	13	UINT8	Input status byte 11	00 hex
				12	14	UINT8	Input status byte 12	00 hex
				13	15	UINT8	Input status byte 13	00 hex
				14	16	UINT8	Input status byte 14	00 hex
				15	17	UINT8	Input status byte 15	00 hex
3	4 bytes	In	0x93 hex	0	18	UINT8	Fieldbus Input byte 0	00 hex
				1	19	UINT8	Fieldbus Input byte 1	00 hex
				2	20	UINT8	Fieldbus Input byte 2	00 hex
				3	21	UINT8	Fieldbus Input byte 3	00 hex
4	4 bytes	In	0x93 hex	0	22	UINT8	Probe status byte 0	00 hex
				1	23	UINT8	Probe status byte 1	00 hex
				2	24	UINT8	Probe status byte 2	00 hex
				3	25	UINT8	Probe status byte 3	00 hex

⁽¹⁾As seen from the perspective of the fieldbus master:

Out The data is received by the communication module from the fieldbus system and transmitted to the Modular Safety Controller

In The Modular Safety Controller provides the data and the communication module makes it available to the fieldbus system.

Slot	Size	Dir. ⁽¹⁾	Type-code	Byte offset		Size	Usage/Name	Default value
				Slot	Global			
5	4 bytes	In	0x93 hex	0	26	UINT8	Safety-related Output status byte 0	00 hex
				1	27	UINT8	Safety-related Output status byte 1	00 hex
				2	28	UINT8	Safety-related Output status byte 2	00 hex
				3	29	UINT8	Safety-related Output status byte 3	00 hex
6	4 bytes	In	0x93 hex	0-3	30-33	FLOAT	Analog data float 0	0.0f
7	4 bytes	In	0x93 hex	0-3	34-37	FLOAT	Analog data float 1	0.0f
8	4 bytes	In	0x93 hex	0-3	38-41	FLOAT	Analog data float 2	0.0f
9	4 bytes	In	0x93 hex	0-3	42-45	FLOAT	Analog data float 3	0.0f
10	4 bytes	In	0x93 hex	0-3	46-49	FLOAT	Analog data float 4	0.0f
11	4 bytes	In	0x93 hex	0-3	50-53	FLOAT	Analog data float 5	0.0f
12	4 bytes	In	0x93 hex	0-3	54-57	FLOAT	Analog data float 6	0.0f
13	4 bytes	In	0x93 hex	0-3	58-61	FLOAT	Analog data float 7	0.0f
14	4 bytes	In	0x93 hex	0-3	62-65	FLOAT	Analog data float 8	0.0f
15	4 bytes	In	0x93 hex	0-3	66-69	FLOAT	Analog data float 9	0.0f
16	4 bytes	In	0x93 hex	0-3	70-73	FLOAT	Analog data float 10	0.0f
17	4 bytes	In	0x93 hex	0-3	74-77	FLOAT	Analog data float 11	0.0f
18	4 bytes	In	0x93 hex	0-3	78-81	FLOAT	Analog data float 12	0.0f
19	4 bytes	In	0x93 hex	0-3	82-85	FLOAT	Analog data float 13	0.0f
20	4 bytes	In	0x93 hex	0-3	86-89	FLOAT	Analog data float 14	0.0f
21	4 bytes	In	0x93 hex	0-3	90-93	FLOAT	Analog data float 15	0.0f
22	4 bytes	Out	0xA3 hex	0	0	UINT8	Fieldbus input byte 0	00 hex
				1	1	UINT8	Fieldbus input byte 1	00 hex
				2	2	UINT8	Fieldbus input byte 2	00 hex
				3	3	UINT8	Fieldbus input byte 3	00 hex

⁽¹⁾As seen from the perspective of the fieldbus master:
Out The data is received by the communication module from the fieldbus system and transmitted to the Modular Safety Controller
In The Modular Safety Controller provides the data and the communication module makes it available to the fieldbus system.

Module "In 30 Byte, Out 4 Byte" (ID = 2, Firmware V2.1.1)

Module ID	2
Data size	30 byte In ⁽¹⁾ / 4 byte Out ⁽¹⁾
Slot(s)	1-6
Config String	0x91,0x9F,0x93,0x93,0x93,0xA3
⁽¹⁾ As seen from the perspective of the fieldbus master: Out The data is received by the communication module from the fieldbus system and transmitted to the Modular Safety Controller In The Modular Safety Controller provides the data and the communication module makes it available to the fieldbus system.	

Slot	Size	Dir. ⁽¹⁾	Type-code	Byte offset		Size	Usage/Name	Default value
				Slot	Global			
1	2 bytes	In	0x91 hex	0	0	UINT8	System status	00 hex
				1	1	UINT8	Reserved	00 hex
2	16 bytes	In	0x9F hex	0	2	UINT8	Input status byte 0	00 hex
				1	3	UINT8	Input status byte 1	00 hex
				2	4	UINT8	Input status byte 2	00 hex
				3	5	UINT8	Input status byte 3	00 hex
				4	6	UINT8	Input status byte 4	00 hex
				5	7	UINT8	Input status byte 5	00 hex
				6	8	UINT8	Input status byte 6	00 hex
				7	9	UINT8	Input status byte 7	00 hex
				8	10	UINT8	Input status byte 8	00 hex
				9	11	UINT8	Input status byte 9	00 hex
				10	12	UINT8	Input status byte 10	00 hex
				11	13	UINT8	Input status byte 11	00 hex
				12	14	UINT8	Input status byte 12	00 hex
				13	15	UINT8	Input status byte 13	00 hex
				14	16	UINT8	Input status byte 14	00 hex
15	17	UINT8	Input status byte 15	00 hex				
⁽¹⁾ As seen from the perspective of the fieldbus master: Out The data is received by the communication module from the fieldbus system and transmitted to the Modular Safety Controller In The Modular Safety Controller provides the data and the communication module makes it available to the fieldbus system.								

Slot	Size	Dir. ⁽¹⁾	Type-code	Byte offset		Size	Usage/Name	Default value
				Slot	Global			
3	4 bytes	In	0x93 hex	0	18	UINT8	Fieldbus Input byte 0	00 hex
				1	19	UINT8	Fieldbus Input byte 1	00 hex
				2	20	UINT8	Fieldbus Input byte 2	00 hex
				3	21	UINT8	Fieldbus Input byte 3	00 hex
4	4 bytes	In	0x93 hex	0	22	UINT8	Probe status byte 0	00 hex
				1	23	UINT8	Probe status byte 1	00 hex
				2	24	UINT8	Probe status byte 2	00 hex
				3	25	UINT8	Probe status byte 3	00 hex
5	4 bytes	In	0x93 hex	0	26	UINT8	Safety-related Output status byte 0	00 hex
				1	27	UINT8	Safety-related Output status byte 1	00 hex
				2	28	UINT8	Safety-related Output status byte 2	00 hex
				3	29	UINT8	Safety-related Output status byte 3	00 hex
6	4 bytes	Out	0xA3 hex	0	0	UINT8	Fieldbus input byte 0	00 hex
				1	1	UINT8	Fieldbus input byte 1	00 hex
				2	2	UINT8	Fieldbus input byte 2	00 hex
				3	3	UINT8	Fieldbus input byte 3	00 hex

⁽¹⁾As seen from the perspective of the fieldbus master:

Out The data is received by the communication module from the fieldbus system and transmitted to the Modular Safety Controller

In The Modular Safety Controller provides the data and the communication module makes it available to the fieldbus system.

Acyclic Data Access

Name	Slot	Index	Length (byte)	Access type
Fieldbus Inputs	01 hex	01 hex	4	Get/Set
System I/O	00 hex	00 hex	30	Get
Analog data	02 hex	05 hex	64	Get
Error data CPU0	00 hex	02 hex	9	Get
Error data CPU1	00 hex	03 hex	9	Get
Input diagnostics	00 hex	04 hex	32	Get
Safety-Related Output Diagnostics	00 hex	05 hex	32	Get

Name	Slot	Index	Length (byte)	Access type
Project CRC	00 hex	06 hex	2	Get

Fieldbus Inputs

Offes	Type	Content	Default value	Access type
0	UINT8	Fieldbus input byte 0	00 hex	Get/Set
1	UINT8	Fieldbus input byte 1	00 hex	Get/Set
2	UINT8	Fieldbus input byte 2	00 hex	Get/Set
3	UINT8	Fieldbus input byte 3	00 hex	Get/Set

System I/O

Offes	Type	Content	Default value	Access type
0	UINT8	System status	00 hex	Get
1	UINT8	Reserved	00 hex	Get
2	UINT8	Input status byte 0	00 hex	Get
3	UINT8	Input status byte 1	00 hex	Get
4	UINT8	Input status byte 2	00 hex	Get
5	UINT8	Input status byte 3	00 hex	Get
6	UINT8	Input status byte 4	00 hex	Get
7	UINT8	Input status byte 5	00 hex	Get
8	UINT8	Input status byte 6	00 hex	Get
9	UINT8	Input status byte 7	00 hex	Get
10	UINT8	Input status byte 8	00 hex	Get
11	UINT8	Input status byte 9	00 hex	Get
12	UINT8	Input status byte 10	00 hex	Get
13	UINT8	Input status byte 11	00 hex	Get
14	UINT8	Input status byte 12	00 hex	Get
15	UINT8	Input status byte 13	00 hex	Get
16	UINT8	Input status byte 14	00 hex	Get
17	UINT8	Input status byte 15	00 hex	Get
18	UINT8	Fieldbus input byte 0 feedback	00 hex	Get
19	UINT8	Fieldbus input byte 1 feedback	00 hex	Get
20	UINT8	Fieldbus input byte 2 feedback	00 hex	Get
21	UINT8	Fieldbus input byte 3 feedback	00 hex	Get

Offes	Type	Content	Default value	Access type
22	UINT8	Probe status byte 0	00 hex	Get
23	UINT8	Probe status byte 1	00 hex	Get
24	UINT8	Probe status byte 2	00 hex	Get
25	UINT8	Probe status byte 3	00 hex	Get
26	UINT8	Safety-related Output status byte 0	00 hex	Get
27	UINT8	Safety-related Output status byte 1	00 hex	Get
28	UINT8	Safety-related Output status byte 2	00 hex	Get
29	UINT8	Safety-related Output status byte 3	00 hex	Get

Analog Data

Offes	Type	Content	Default v alue	Access type
0-3	FLOAT	Analog data float 0	0.0f	Get
4-7	FLOAT	Analog data float 1	0.0f	Get
8-11	FLOAT	Analog data float 2	0.0f	Get
12-15	FLOAT	Analog data float 3	0.0f	Get
16-19	FLOAT	Analog data float 4	0.0f	Get
20-23	FLOAT	Analog data float 5	0.0f	Get
24-27	FLOAT	Analog data float 6	0.0f	Get
28-31	FLOAT	Analog data float 7	0.0f	Get
32-35	FLOAT	Analog data float 8	0.0f	Get
36-39	FLOAT	Analog data float 9	0.0f	Get
40-43	FLOAT	Analog data float 10	0.0f	Get
44-47	FLOAT	Analog data float 11	0.0f	Get
48-51	FLOAT	Analog data float 12	0.0f	Get
52-55	FLOAT	Analog data float 13	0.0f	Get
56-59	FLOAT	Analog data float 14	0.0f	Get
60-63	FLOAT	Analog data float 15	0.0f	Get

Error Data CPU0 and CPU1

Offes	Type	Content	Default v alue	Access type
0	UINT8	Module ID	00 hex	Get
1	UINT8	Error code	00 hex	Get
2-5	UINT32	Error address	00000000 hex	Get
6	UINT8	Fieldbus input byte 3	00 hex	Get
7	UINT8	CPU firmware version	00 hex	Get
8	UINT8	Extended code 0 (Optional)	00 hex	Get
9	UINT8	Extended code 1 (Optional)	00 hex	Get

Input Diagnostics

Offes	Type	Content	Default value	Access type
0	UINT8	Diagnostic index 0	00 hex	Get
1	UINT8	Diagnostic code 0	00 hex	Get
2	UINT8	Diagnostic index 1	00 hex	Get
3	UINT8	Diagnostic code 1	00 hex	Get
4	UINT8	Diagnostic index 2	00 hex	Get
5	UINT8	Diagnostic code 2	00 hex	Get
6	UINT8	Diagnostic index 3	00 hex	Get
7	UINT8	Diagnostic code 3	00 hex	Get
8	UINT8	Diagnostic index 4	00 hex	Get
9	UINT8	Diagnostic code 4	00 hex	Get
10	UINT8	Diagnostic index 5	00 hex	Get
11	UINT8	Diagnostic code 5	00 hex	Get
12	UINT8	Diagnostic index 6	00 hex	Get
13	UINT8	Diagnostic code 6	00 hex	Get
14	UINT8	Diagnostic index 7	00 hex	Get
15	UINT8	Diagnostic code 7	00 hex	Get
16	UINT8	Diagnostic index 8	00 hex	Get
17	UINT8	Diagnostic code 8	00 hex	Get
18	UINT8	Diagnostic index 9	00 hex	Get
19	UINT8	Diagnostic code 9	00 hex	Get
20	UINT8	Diagnostic index 10	00 hex	Get
21	UINT8	Diagnostic code 10	00 hex	Get

Offes	Type	Content	Default value	Access type
22	UINT8	Diagnostic index 11	00 hex	Get
23	UINT8	Diagnostic code 11	00 hex	Get
24	UINT8	Diagnostic index 12	00 hex	Get
25	UINT8	Diagnostic code 12	00 hex	Get
26	UINT8	Diagnostic index 13	00 hex	Get
27	UINT8	Diagnostic code 13	00 hex	Get
28	UINT8	Diagnostic index 14	00 hex	Get
29	UINT8	Diagnostic code 14	00 hex	Get
30	UINT8	Diagnostic index 15	00 hex	Get
31	UINT8	Diagnostic code 15	00 hex	Get

Safety-related Output Diagnostic

Offes	Type	Content	Default value	Access type
0	UINT8	Diagnostic index 0	00 hex	Get
1	UINT8	Diagnostic code 0	00 hex	Get
2	UINT8	Diagnostic index 1	00 hex	Get
3	UINT8	Diagnostic code 1	00 hex	Get
4	UINT8	Diagnostic index 2	00 hex	Get
5	UINT8	Diagnostic code 2	00 hex	Get
6	UINT8	Diagnostic index 3	00 hex	Get
7	UINT8	Diagnostic code 3	00 hex	Get
8	UINT8	Diagnostic index 4	00 hex	Get
9	UINT8	Diagnostic code 4	00 hex	Get
10	UINT8	Diagnostic index 5	00 hex	Get
11	UINT8	Diagnostic code 5	00 hex	Get
12	UINT8	Diagnostic index 6	00 hex	Get
13	UINT8	Diagnostic code 6	00 hex	Get
14	UINT8	Diagnostic index 7	00 hex	Get
15	UINT8	Diagnostic code 7	00 hex	Get
16	UINT8	Diagnostic index 8	00 hex	Get
17	UINT8	Diagnostic code 8	00 hex	Get
18	UINT8	Diagnostic index 9	00 hex	Get
19	UINT8	Diagnostic code 9	00 hex	Get
20	UINT8	Diagnostic index 10	00 hex	Get

Offes	Type	Content	Default value	Access type
21	UINT8	Diagnostic code 10	00 hex	Get
22	UINT8	Diagnostic index 11	00 hex	Get
23	UINT8	Diagnostic code 11	00 hex	Get
24	UINT8	Diagnostic index 12	00 hex	Get
25	UINT8	Diagnostic code 12	00 hex	Get
26	UINT8	Diagnostic index 13	00 hex	Get
27	UINT8	Diagnostic code 13	00 hex	Get
28	UINT8	Diagnostic index 14	00 hex	Get
29	UINT8	Diagnostic code 14	00 hex	Get
30	UINT8	Diagnostic index 15	00 hex	Get
31	UINT8	Diagnostic code 15	00 hex	Get

Project CRC

Offes	Type	Content	Default value	Access type
0	UINT8	Project CRC, low byte	00 hex	Get
1	UINT8	Project CRC, high byte	00 hex	Get

Part II

SoSafe Configurable

Chapter 2

BUS Configurator Software

What Is in This Chapter?

This chapter contains the following topics:

Topic	Page
Bus Configurator Overview	100
Connection, Configuration and Monitoring/Diagnostics	103
Examples	110
Configuration Example in SoSafe Configurable and Representation in BUS Configurator	117
XPSMCMCO0000• Fieldbus Modules Compatibility Chart	120

Bus Configurator Overview

Overview

The fieldbus module is configured using the USB/Mini B USB interface on the front panel and the BUS Configurator software. The BUS Configurator software is installed along with the SoSafe Configurable software. Once the BUS Configurator software has been correctly installed,

it creates a gray shortcut icon on the desktop .

To launch the program, double-click the icon.

This software can be used for the configuration and communication of the system with a PC, and to display information on the input data map as well as the output data map (such as states of inputs and outputs, diagnostics information, etc.)

Example of Connection

Example of a connection XPSMCMCP0802• to XPSMCMCO0000• (fieldbus):

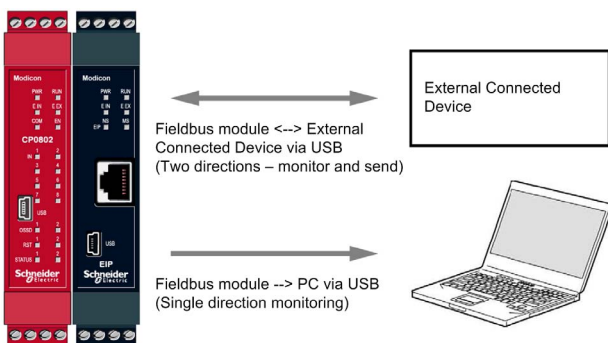

NOTE:

The following can be configured using BUS Configurator:

- Data to be transmitted to and from the Modular Safety Controller via the fieldbus (analog data can be enabled/disabled)
- Fieldbus address of the module
- Transmission rate

Presentation of the Graphical User Interface (GUI)

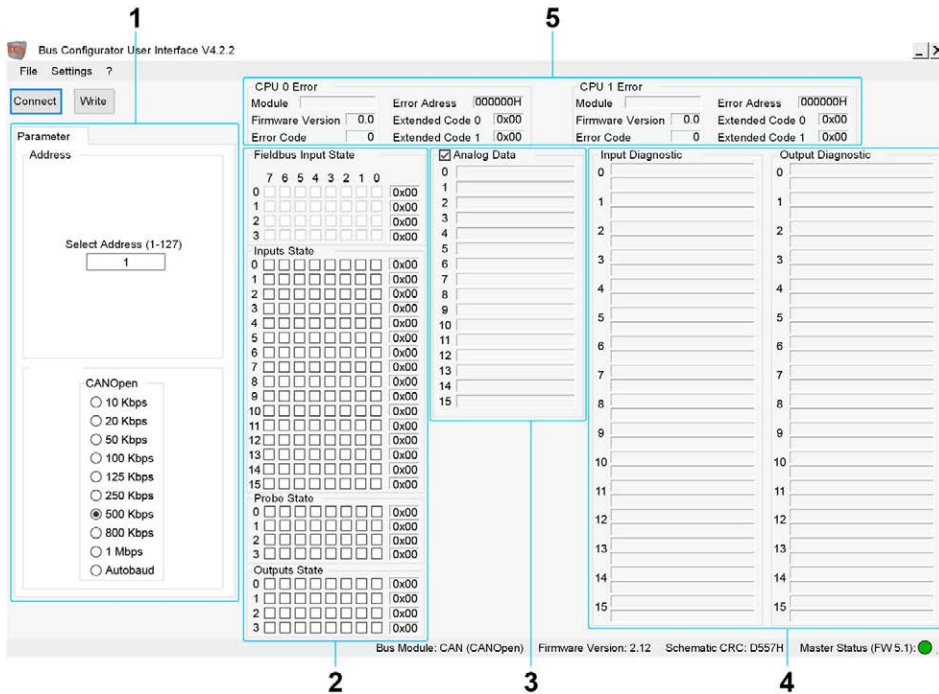

	GUI section	Description
1	Parameter	This section provides access to the two parameters (<i>see page 104</i>) to configure the XPSMCMCO0000+ fieldbus: <ul style="list-style-type: none"> ● Address ● Baudrate
2	Fieldbus Input/Output	This section provides information on the states of: <ul style="list-style-type: none"> ● Fieldbus Input State ● Inputs State ● Probe State ● Outputs State
3	Analog Data	This section is used to enable or disable the transfer of the analog data from the Modular Safety Controller to the logic controller.
4	Input Diagnostic and Output Diagnostic	These sections provide diagnostics information on the input and output function blocks.

	GUI section	Description
5	CPU 0 Error and CPU 1 Error	These sections provide information on detected errors on the processors of the Modular Safety Controller: <ul style="list-style-type: none"> ● Module in error ● Error address ● Error code

Connection, Configuration and Monitoring/Diagnostics

Connecting to the Modular Safety Controller

⚠ WARNING

UNINTENDED EQUIPMENT OPERATION

Do not configure a fieldbus module while the machine is in operation.

Failure to follow these instructions can result in death, serious injury, or equipment damage.

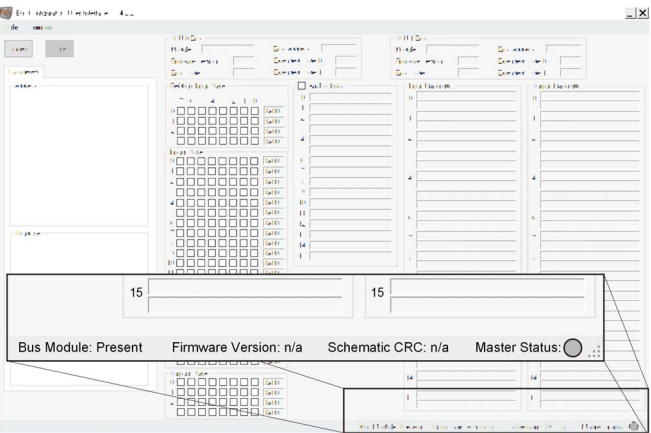
Step	Action	Result
1	Connect the module to the 24 Vdc power supply via the terminal block.	–
2	Connect the USB cable to the PC and to the fieldbus module.	–
3	Open the BUS Configurator - User Interface .	<p>The program detects that a fieldbus module is connected.</p> 

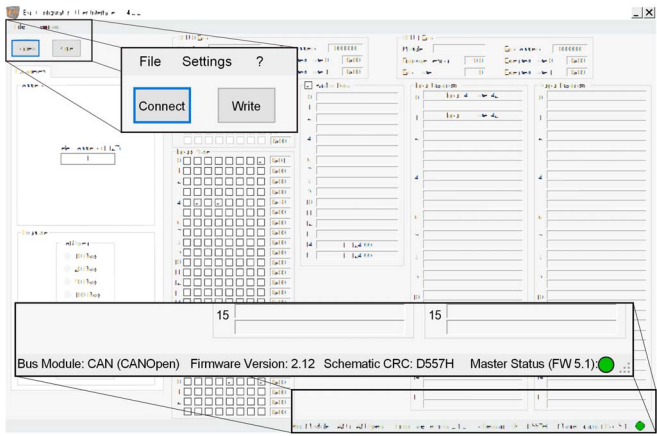
Step	Action	Result
4	Click Connect .	<p>The program reads the fieldbus module data.</p>  <p>The fieldbus type, firmware version, program CRC, Modular Safety Controller (XPSMCMCP0802•) version and state are displayed (<i>see page 107</i>).</p>

Configuration Section

The options available for the address depend on the type of fieldbus detected.

Communication Parameters

The following table indicates the default addresses depending on the fieldbus type:

Fieldbus	Address
XPSMCMCO0000CO• CANopen	127
XPSMCMCO0000EC• EtherCAT	N/A
XPSMCMCO0000EI• EtherNet/IP	DHCP assigned address
XPSMCMCO0000MB• Modbus RTU	1
XPSMCMCO0000EM• Modbus TCP	DHCP assigned address
XPSMCMCO0000PB• Profibus	126

The following table indicates the default communication rates depending on the fieldbus type:

Fieldbus	Address
XPSMCMCO0000CO• CANopen	AUTOBAUD
XPSMCMCO0000EC• EtherCAT	AUTO

Fieldbus	Address
XPSMCMCO0000EI• EtherNet/IP	AUTO
XPSMCMCO0000MB• Modbus RTU	AUTO
XPSMCMCO0000EM• Modbus TCP	AUTO
XPSMCMCO0000PB• Profibus	AUTOBAUD

The options available for the address and communication rate depend on the type of fieldbus detected. To manually configure addresses and rates, select the **Parameters** tab.

Data Configuration Section

Parameter	Description																																
Analog Data	<p>With the checkbox, you can enable or disable the transfer of the Analog data from the Modular Safety Controller to the logic controller. By default, the Analog data are not transferred in order to reduce the amount of cyclic data and keep the transfer cycle as small as possible.</p> <div style="border: 1px solid gray; padding: 5px; margin-top: 10px;"> <input checked="" type="checkbox"/> Analog Data <table style="width: 100%; border-collapse: collapse;"> <tr><td style="width: 20px;">0</td><td><input type="text"/></td></tr> <tr><td>1</td><td><input type="text"/></td></tr> <tr><td>2</td><td><input type="text"/></td></tr> <tr><td>3</td><td><input type="text"/></td></tr> <tr><td>4</td><td><input type="text"/></td></tr> <tr><td>5</td><td><input type="text"/></td></tr> <tr><td>6</td><td><input type="text"/></td></tr> <tr><td>7</td><td><input type="text"/></td></tr> <tr><td>8</td><td><input type="text"/></td></tr> <tr><td>9</td><td><input type="text"/></td></tr> <tr><td>10</td><td><input type="text"/></td></tr> <tr><td>11</td><td><input type="text"/></td></tr> <tr><td>12</td><td><input type="text"/></td></tr> <tr><td>13</td><td><input type="text"/></td></tr> <tr><td>14</td><td><input type="text"/></td></tr> <tr><td>15</td><td><input type="text"/></td></tr> </table> </div>	0	<input type="text"/>	1	<input type="text"/>	2	<input type="text"/>	3	<input type="text"/>	4	<input type="text"/>	5	<input type="text"/>	6	<input type="text"/>	7	<input type="text"/>	8	<input type="text"/>	9	<input type="text"/>	10	<input type="text"/>	11	<input type="text"/>	12	<input type="text"/>	13	<input type="text"/>	14	<input type="text"/>	15	<input type="text"/>
0	<input type="text"/>																																
1	<input type="text"/>																																
2	<input type="text"/>																																
3	<input type="text"/>																																
4	<input type="text"/>																																
5	<input type="text"/>																																
6	<input type="text"/>																																
7	<input type="text"/>																																
8	<input type="text"/>																																
9	<input type="text"/>																																
10	<input type="text"/>																																
11	<input type="text"/>																																
12	<input type="text"/>																																
13	<input type="text"/>																																
14	<input type="text"/>																																
15	<input type="text"/>																																

Click the **Write** button to save the configuration to the Modular Safety Controller.

Monitor Section

The monitor section displays the status of the I/O of the system, if the Modular Safety Controller is running.

Status Bar

At the bottom of the main BUS Configurator window, the LED shows the status of the XPSMCMCP0802•:

- **Gray** = not connected
- **Green** = XPSMCMCP0802• active (RUN)
- **Red** = XPSMCMCP0802• not active (for example, XPSMCMCP0802• is connected with SoSafe Configurable software)
- **Orange** = configuration data transmitted to and from XPSMCMCP0802•

Bus Module: CAN (CANOpen) Firmware Version: 2.12 Schematic CRC: D557H Master Status (FW 5.1): 

Monitor Data

The following table describes the status of the system I/O shown in the monitor section.

Representation	Description																																																																																																																																																																																																																																																																																																		
<div style="border: 1px solid gray; padding: 5px;"> <p>Fieldbus Input State</p> <table style="width: 100%; border-collapse: collapse;"> <tr> <td></td> <td style="text-align: center;">7</td> <td style="text-align: center;">6</td> <td style="text-align: center;">5</td> <td style="text-align: center;">4</td> <td style="text-align: center;">3</td> <td style="text-align: center;">2</td> <td style="text-align: center;">1</td> <td style="text-align: center;">0</td> <td></td> </tr> <tr> <td>0</td> <td><input type="checkbox"/></td> <td><input type="checkbox"/></td> <td><input type="checkbox"/></td> <td><input type="checkbox"/></td> <td><input type="checkbox"/></td> <td><input type="checkbox"/></td> <td><input type="checkbox"/></td> <td><input type="checkbox"/></td> <td>0x00</td> </tr> <tr> <td>1</td> <td><input type="checkbox"/></td> <td><input type="checkbox"/></td> <td><input type="checkbox"/></td> <td><input type="checkbox"/></td> <td><input type="checkbox"/></td> <td><input type="checkbox"/></td> <td><input type="checkbox"/></td> <td><input type="checkbox"/></td> <td>0x00</td> </tr> <tr> <td>2</td> <td><input type="checkbox"/></td> <td><input type="checkbox"/></td> <td><input type="checkbox"/></td> <td><input type="checkbox"/></td> <td><input type="checkbox"/></td> <td><input type="checkbox"/></td> <td><input type="checkbox"/></td> <td><input type="checkbox"/></td> <td>0x00</td> </tr> <tr> <td>3</td> <td><input type="checkbox"/></td> <td><input type="checkbox"/></td> <td><input type="checkbox"/></td> <td><input type="checkbox"/></td> <td><input type="checkbox"/></td> <td><input type="checkbox"/></td> <td><input type="checkbox"/></td> <td><input type="checkbox"/></td> <td>0x00</td> </tr> </table> <p>Inputs State</p> <table style="width: 100%; border-collapse: collapse;"> <tr><td>0</td><td><input type="checkbox"/></td><td><input type="checkbox"/></td><td><input type="checkbox"/></td><td><input type="checkbox"/></td><td><input type="checkbox"/></td><td><input type="checkbox"/></td><td><input type="checkbox"/></td><td><input type="checkbox"/></td><td>0x00</td></tr> <tr><td>1</td><td><input type="checkbox"/></td><td><input type="checkbox"/></td><td><input type="checkbox"/></td><td><input type="checkbox"/></td><td><input type="checkbox"/></td><td><input type="checkbox"/></td><td><input type="checkbox"/></td><td><input type="checkbox"/></td><td>0x00</td></tr> <tr><td>2</td><td><input type="checkbox"/></td><td><input type="checkbox"/></td><td><input type="checkbox"/></td><td><input type="checkbox"/></td><td><input type="checkbox"/></td><td><input type="checkbox"/></td><td><input type="checkbox"/></td><td><input type="checkbox"/></td><td>0x00</td></tr> <tr><td>3</td><td><input type="checkbox"/></td><td><input type="checkbox"/></td><td><input type="checkbox"/></td><td><input type="checkbox"/></td><td><input type="checkbox"/></td><td><input type="checkbox"/></td><td><input type="checkbox"/></td><td><input type="checkbox"/></td><td>0x00</td></tr> <tr><td>4</td><td><input type="checkbox"/></td><td><input type="checkbox"/></td><td><input type="checkbox"/></td><td><input type="checkbox"/></td><td><input type="checkbox"/></td><td><input type="checkbox"/></td><td><input type="checkbox"/></td><td><input type="checkbox"/></td><td>0x00</td></tr> <tr><td>5</td><td><input type="checkbox"/></td><td><input type="checkbox"/></td><td><input type="checkbox"/></td><td><input type="checkbox"/></td><td><input type="checkbox"/></td><td><input type="checkbox"/></td><td><input type="checkbox"/></td><td><input type="checkbox"/></td><td>0x00</td></tr> <tr><td>6</td><td><input type="checkbox"/></td><td><input type="checkbox"/></td><td><input type="checkbox"/></td><td><input type="checkbox"/></td><td><input type="checkbox"/></td><td><input type="checkbox"/></td><td><input type="checkbox"/></td><td><input type="checkbox"/></td><td>0x00</td></tr> <tr><td>7</td><td><input type="checkbox"/></td><td><input type="checkbox"/></td><td><input type="checkbox"/></td><td><input type="checkbox"/></td><td><input type="checkbox"/></td><td><input type="checkbox"/></td><td><input type="checkbox"/></td><td><input type="checkbox"/></td><td>0x00</td></tr> <tr><td>8</td><td><input type="checkbox"/></td><td><input type="checkbox"/></td><td><input type="checkbox"/></td><td><input type="checkbox"/></td><td><input type="checkbox"/></td><td><input type="checkbox"/></td><td><input type="checkbox"/></td><td><input type="checkbox"/></td><td>0x00</td></tr> <tr><td>9</td><td><input type="checkbox"/></td><td><input type="checkbox"/></td><td><input type="checkbox"/></td><td><input type="checkbox"/></td><td><input type="checkbox"/></td><td><input type="checkbox"/></td><td><input type="checkbox"/></td><td><input type="checkbox"/></td><td>0x00</td></tr> <tr><td>10</td><td><input type="checkbox"/></td><td><input type="checkbox"/></td><td><input type="checkbox"/></td><td><input type="checkbox"/></td><td><input type="checkbox"/></td><td><input type="checkbox"/></td><td><input type="checkbox"/></td><td><input type="checkbox"/></td><td>0x00</td></tr> <tr><td>11</td><td><input type="checkbox"/></td><td><input type="checkbox"/></td><td><input type="checkbox"/></td><td><input type="checkbox"/></td><td><input type="checkbox"/></td><td><input type="checkbox"/></td><td><input type="checkbox"/></td><td><input type="checkbox"/></td><td>0x00</td></tr> <tr><td>12</td><td><input type="checkbox"/></td><td><input type="checkbox"/></td><td><input type="checkbox"/></td><td><input type="checkbox"/></td><td><input type="checkbox"/></td><td><input type="checkbox"/></td><td><input type="checkbox"/></td><td><input type="checkbox"/></td><td>0x00</td></tr> <tr><td>13</td><td><input type="checkbox"/></td><td><input type="checkbox"/></td><td><input type="checkbox"/></td><td><input type="checkbox"/></td><td><input type="checkbox"/></td><td><input type="checkbox"/></td><td><input type="checkbox"/></td><td><input type="checkbox"/></td><td>0x00</td></tr> <tr><td>14</td><td><input type="checkbox"/></td><td><input type="checkbox"/></td><td><input type="checkbox"/></td><td><input type="checkbox"/></td><td><input type="checkbox"/></td><td><input type="checkbox"/></td><td><input type="checkbox"/></td><td><input type="checkbox"/></td><td>0x00</td></tr> <tr><td>15</td><td><input type="checkbox"/></td><td><input type="checkbox"/></td><td><input type="checkbox"/></td><td><input type="checkbox"/></td><td><input type="checkbox"/></td><td><input type="checkbox"/></td><td><input type="checkbox"/></td><td><input type="checkbox"/></td><td>0x00</td></tr> </table> <p>Probe State</p> <table style="width: 100%; border-collapse: collapse;"> <tr><td>0</td><td><input type="checkbox"/></td><td><input type="checkbox"/></td><td><input type="checkbox"/></td><td><input type="checkbox"/></td><td><input type="checkbox"/></td><td><input type="checkbox"/></td><td><input type="checkbox"/></td><td><input type="checkbox"/></td><td>0x00</td></tr> <tr><td>1</td><td><input type="checkbox"/></td><td><input type="checkbox"/></td><td><input type="checkbox"/></td><td><input type="checkbox"/></td><td><input type="checkbox"/></td><td><input type="checkbox"/></td><td><input type="checkbox"/></td><td><input type="checkbox"/></td><td>0x00</td></tr> <tr><td>2</td><td><input type="checkbox"/></td><td><input type="checkbox"/></td><td><input type="checkbox"/></td><td><input type="checkbox"/></td><td><input type="checkbox"/></td><td><input type="checkbox"/></td><td><input type="checkbox"/></td><td><input type="checkbox"/></td><td>0x00</td></tr> <tr><td>3</td><td><input type="checkbox"/></td><td><input type="checkbox"/></td><td><input type="checkbox"/></td><td><input type="checkbox"/></td><td><input type="checkbox"/></td><td><input type="checkbox"/></td><td><input type="checkbox"/></td><td><input type="checkbox"/></td><td>0x00</td></tr> </table> <p>Outputs State</p> <table style="width: 100%; border-collapse: collapse;"> <tr><td>0</td><td><input type="checkbox"/></td><td><input type="checkbox"/></td><td><input type="checkbox"/></td><td><input type="checkbox"/></td><td><input type="checkbox"/></td><td><input type="checkbox"/></td><td><input type="checkbox"/></td><td><input type="checkbox"/></td><td>0x00</td></tr> <tr><td>1</td><td><input type="checkbox"/></td><td><input type="checkbox"/></td><td><input type="checkbox"/></td><td><input type="checkbox"/></td><td><input type="checkbox"/></td><td><input type="checkbox"/></td><td><input type="checkbox"/></td><td><input type="checkbox"/></td><td>0x00</td></tr> <tr><td>2</td><td><input type="checkbox"/></td><td><input type="checkbox"/></td><td><input type="checkbox"/></td><td><input type="checkbox"/></td><td><input type="checkbox"/></td><td><input type="checkbox"/></td><td><input type="checkbox"/></td><td><input type="checkbox"/></td><td>0x00</td></tr> <tr><td>3</td><td><input type="checkbox"/></td><td><input type="checkbox"/></td><td><input type="checkbox"/></td><td><input type="checkbox"/></td><td><input type="checkbox"/></td><td><input type="checkbox"/></td><td><input type="checkbox"/></td><td><input type="checkbox"/></td><td>0x00</td></tr> </table> </div>		7	6	5	4	3	2	1	0		0	<input type="checkbox"/>	<input type="checkbox"/>	<input type="checkbox"/>	<input type="checkbox"/>	<input type="checkbox"/>	<input type="checkbox"/>	<input type="checkbox"/>	<input type="checkbox"/>	0x00	1	<input type="checkbox"/>	<input type="checkbox"/>	<input type="checkbox"/>	<input type="checkbox"/>	<input type="checkbox"/>	<input type="checkbox"/>	<input type="checkbox"/>	<input type="checkbox"/>	0x00	2	<input type="checkbox"/>	<input type="checkbox"/>	<input type="checkbox"/>	<input type="checkbox"/>	<input type="checkbox"/>	<input type="checkbox"/>	<input type="checkbox"/>	<input type="checkbox"/>	0x00	3	<input type="checkbox"/>	<input type="checkbox"/>	<input type="checkbox"/>	<input type="checkbox"/>	<input type="checkbox"/>	<input type="checkbox"/>	<input type="checkbox"/>	<input type="checkbox"/>	0x00	0	<input type="checkbox"/>	<input type="checkbox"/>	<input type="checkbox"/>	<input type="checkbox"/>	<input type="checkbox"/>	<input type="checkbox"/>	<input type="checkbox"/>	<input type="checkbox"/>	0x00	1	<input type="checkbox"/>	<input type="checkbox"/>	<input type="checkbox"/>	<input type="checkbox"/>	<input type="checkbox"/>	<input type="checkbox"/>	<input type="checkbox"/>	<input type="checkbox"/>	0x00	2	<input type="checkbox"/>	<input type="checkbox"/>	<input type="checkbox"/>	<input type="checkbox"/>	<input type="checkbox"/>	<input type="checkbox"/>	<input type="checkbox"/>	<input type="checkbox"/>	0x00	3	<input type="checkbox"/>	<input type="checkbox"/>	<input type="checkbox"/>	<input type="checkbox"/>	<input type="checkbox"/>	<input type="checkbox"/>	<input type="checkbox"/>	<input type="checkbox"/>	0x00	4	<input type="checkbox"/>	<input type="checkbox"/>	<input type="checkbox"/>	<input type="checkbox"/>	<input type="checkbox"/>	<input type="checkbox"/>	<input type="checkbox"/>	<input type="checkbox"/>	0x00	5	<input type="checkbox"/>	<input type="checkbox"/>	<input type="checkbox"/>	<input type="checkbox"/>	<input type="checkbox"/>	<input type="checkbox"/>	<input type="checkbox"/>	<input type="checkbox"/>	0x00	6	<input type="checkbox"/>	<input type="checkbox"/>	<input type="checkbox"/>	<input type="checkbox"/>	<input type="checkbox"/>	<input type="checkbox"/>	<input type="checkbox"/>	<input type="checkbox"/>	0x00	7	<input type="checkbox"/>	<input type="checkbox"/>	<input type="checkbox"/>	<input type="checkbox"/>	<input type="checkbox"/>	<input type="checkbox"/>	<input type="checkbox"/>	<input type="checkbox"/>	0x00	8	<input type="checkbox"/>	<input type="checkbox"/>	<input type="checkbox"/>	<input type="checkbox"/>	<input type="checkbox"/>	<input type="checkbox"/>	<input type="checkbox"/>	<input type="checkbox"/>	0x00	9	<input type="checkbox"/>	<input type="checkbox"/>	<input type="checkbox"/>	<input type="checkbox"/>	<input type="checkbox"/>	<input type="checkbox"/>	<input type="checkbox"/>	<input type="checkbox"/>	0x00	10	<input type="checkbox"/>	<input type="checkbox"/>	<input type="checkbox"/>	<input type="checkbox"/>	<input type="checkbox"/>	<input type="checkbox"/>	<input type="checkbox"/>	<input type="checkbox"/>	0x00	11	<input type="checkbox"/>	<input type="checkbox"/>	<input type="checkbox"/>	<input type="checkbox"/>	<input type="checkbox"/>	<input type="checkbox"/>	<input type="checkbox"/>	<input type="checkbox"/>	0x00	12	<input type="checkbox"/>	<input type="checkbox"/>	<input type="checkbox"/>	<input type="checkbox"/>	<input type="checkbox"/>	<input type="checkbox"/>	<input type="checkbox"/>	<input type="checkbox"/>	0x00	13	<input type="checkbox"/>	<input type="checkbox"/>	<input type="checkbox"/>	<input type="checkbox"/>	<input type="checkbox"/>	<input type="checkbox"/>	<input type="checkbox"/>	<input type="checkbox"/>	0x00	14	<input type="checkbox"/>	<input type="checkbox"/>	<input type="checkbox"/>	<input type="checkbox"/>	<input type="checkbox"/>	<input type="checkbox"/>	<input type="checkbox"/>	<input type="checkbox"/>	0x00	15	<input type="checkbox"/>	<input type="checkbox"/>	<input type="checkbox"/>	<input type="checkbox"/>	<input type="checkbox"/>	<input type="checkbox"/>	<input type="checkbox"/>	<input type="checkbox"/>	0x00	0	<input type="checkbox"/>	<input type="checkbox"/>	<input type="checkbox"/>	<input type="checkbox"/>	<input type="checkbox"/>	<input type="checkbox"/>	<input type="checkbox"/>	<input type="checkbox"/>	0x00	1	<input type="checkbox"/>	<input type="checkbox"/>	<input type="checkbox"/>	<input type="checkbox"/>	<input type="checkbox"/>	<input type="checkbox"/>	<input type="checkbox"/>	<input type="checkbox"/>	0x00	2	<input type="checkbox"/>	<input type="checkbox"/>	<input type="checkbox"/>	<input type="checkbox"/>	<input type="checkbox"/>	<input type="checkbox"/>	<input type="checkbox"/>	<input type="checkbox"/>	0x00	3	<input type="checkbox"/>	<input type="checkbox"/>	<input type="checkbox"/>	<input type="checkbox"/>	<input type="checkbox"/>	<input type="checkbox"/>	<input type="checkbox"/>	<input type="checkbox"/>	0x00	0	<input type="checkbox"/>	<input type="checkbox"/>	<input type="checkbox"/>	<input type="checkbox"/>	<input type="checkbox"/>	<input type="checkbox"/>	<input type="checkbox"/>	<input type="checkbox"/>	0x00	1	<input type="checkbox"/>	<input type="checkbox"/>	<input type="checkbox"/>	<input type="checkbox"/>	<input type="checkbox"/>	<input type="checkbox"/>	<input type="checkbox"/>	<input type="checkbox"/>	0x00	2	<input type="checkbox"/>	<input type="checkbox"/>	<input type="checkbox"/>	<input type="checkbox"/>	<input type="checkbox"/>	<input type="checkbox"/>	<input type="checkbox"/>	<input type="checkbox"/>	0x00	3	<input type="checkbox"/>	<input type="checkbox"/>	<input type="checkbox"/>	<input type="checkbox"/>	<input type="checkbox"/>	<input type="checkbox"/>	<input type="checkbox"/>	<input type="checkbox"/>	0x00	<p>Fieldbus Input State</p> <p>This section provides the states of the following function blocks:</p> <ul style="list-style-type: none"> ● Fieldbus inputs ● Inputs ● Fieldbus probes ● Safety-related outputs
	7	6	5	4	3	2	1	0																																																																																																																																																																																																																																																																																											
0	<input type="checkbox"/>	<input type="checkbox"/>	<input type="checkbox"/>	<input type="checkbox"/>	<input type="checkbox"/>	<input type="checkbox"/>	<input type="checkbox"/>	<input type="checkbox"/>	0x00																																																																																																																																																																																																																																																																																										
1	<input type="checkbox"/>	<input type="checkbox"/>	<input type="checkbox"/>	<input type="checkbox"/>	<input type="checkbox"/>	<input type="checkbox"/>	<input type="checkbox"/>	<input type="checkbox"/>	0x00																																																																																																																																																																																																																																																																																										
2	<input type="checkbox"/>	<input type="checkbox"/>	<input type="checkbox"/>	<input type="checkbox"/>	<input type="checkbox"/>	<input type="checkbox"/>	<input type="checkbox"/>	<input type="checkbox"/>	0x00																																																																																																																																																																																																																																																																																										
3	<input type="checkbox"/>	<input type="checkbox"/>	<input type="checkbox"/>	<input type="checkbox"/>	<input type="checkbox"/>	<input type="checkbox"/>	<input type="checkbox"/>	<input type="checkbox"/>	0x00																																																																																																																																																																																																																																																																																										
0	<input type="checkbox"/>	<input type="checkbox"/>	<input type="checkbox"/>	<input type="checkbox"/>	<input type="checkbox"/>	<input type="checkbox"/>	<input type="checkbox"/>	<input type="checkbox"/>	0x00																																																																																																																																																																																																																																																																																										
1	<input type="checkbox"/>	<input type="checkbox"/>	<input type="checkbox"/>	<input type="checkbox"/>	<input type="checkbox"/>	<input type="checkbox"/>	<input type="checkbox"/>	<input type="checkbox"/>	0x00																																																																																																																																																																																																																																																																																										
2	<input type="checkbox"/>	<input type="checkbox"/>	<input type="checkbox"/>	<input type="checkbox"/>	<input type="checkbox"/>	<input type="checkbox"/>	<input type="checkbox"/>	<input type="checkbox"/>	0x00																																																																																																																																																																																																																																																																																										
3	<input type="checkbox"/>	<input type="checkbox"/>	<input type="checkbox"/>	<input type="checkbox"/>	<input type="checkbox"/>	<input type="checkbox"/>	<input type="checkbox"/>	<input type="checkbox"/>	0x00																																																																																																																																																																																																																																																																																										
4	<input type="checkbox"/>	<input type="checkbox"/>	<input type="checkbox"/>	<input type="checkbox"/>	<input type="checkbox"/>	<input type="checkbox"/>	<input type="checkbox"/>	<input type="checkbox"/>	0x00																																																																																																																																																																																																																																																																																										
5	<input type="checkbox"/>	<input type="checkbox"/>	<input type="checkbox"/>	<input type="checkbox"/>	<input type="checkbox"/>	<input type="checkbox"/>	<input type="checkbox"/>	<input type="checkbox"/>	0x00																																																																																																																																																																																																																																																																																										
6	<input type="checkbox"/>	<input type="checkbox"/>	<input type="checkbox"/>	<input type="checkbox"/>	<input type="checkbox"/>	<input type="checkbox"/>	<input type="checkbox"/>	<input type="checkbox"/>	0x00																																																																																																																																																																																																																																																																																										
7	<input type="checkbox"/>	<input type="checkbox"/>	<input type="checkbox"/>	<input type="checkbox"/>	<input type="checkbox"/>	<input type="checkbox"/>	<input type="checkbox"/>	<input type="checkbox"/>	0x00																																																																																																																																																																																																																																																																																										
8	<input type="checkbox"/>	<input type="checkbox"/>	<input type="checkbox"/>	<input type="checkbox"/>	<input type="checkbox"/>	<input type="checkbox"/>	<input type="checkbox"/>	<input type="checkbox"/>	0x00																																																																																																																																																																																																																																																																																										
9	<input type="checkbox"/>	<input type="checkbox"/>	<input type="checkbox"/>	<input type="checkbox"/>	<input type="checkbox"/>	<input type="checkbox"/>	<input type="checkbox"/>	<input type="checkbox"/>	0x00																																																																																																																																																																																																																																																																																										
10	<input type="checkbox"/>	<input type="checkbox"/>	<input type="checkbox"/>	<input type="checkbox"/>	<input type="checkbox"/>	<input type="checkbox"/>	<input type="checkbox"/>	<input type="checkbox"/>	0x00																																																																																																																																																																																																																																																																																										
11	<input type="checkbox"/>	<input type="checkbox"/>	<input type="checkbox"/>	<input type="checkbox"/>	<input type="checkbox"/>	<input type="checkbox"/>	<input type="checkbox"/>	<input type="checkbox"/>	0x00																																																																																																																																																																																																																																																																																										
12	<input type="checkbox"/>	<input type="checkbox"/>	<input type="checkbox"/>	<input type="checkbox"/>	<input type="checkbox"/>	<input type="checkbox"/>	<input type="checkbox"/>	<input type="checkbox"/>	0x00																																																																																																																																																																																																																																																																																										
13	<input type="checkbox"/>	<input type="checkbox"/>	<input type="checkbox"/>	<input type="checkbox"/>	<input type="checkbox"/>	<input type="checkbox"/>	<input type="checkbox"/>	<input type="checkbox"/>	0x00																																																																																																																																																																																																																																																																																										
14	<input type="checkbox"/>	<input type="checkbox"/>	<input type="checkbox"/>	<input type="checkbox"/>	<input type="checkbox"/>	<input type="checkbox"/>	<input type="checkbox"/>	<input type="checkbox"/>	0x00																																																																																																																																																																																																																																																																																										
15	<input type="checkbox"/>	<input type="checkbox"/>	<input type="checkbox"/>	<input type="checkbox"/>	<input type="checkbox"/>	<input type="checkbox"/>	<input type="checkbox"/>	<input type="checkbox"/>	0x00																																																																																																																																																																																																																																																																																										
0	<input type="checkbox"/>	<input type="checkbox"/>	<input type="checkbox"/>	<input type="checkbox"/>	<input type="checkbox"/>	<input type="checkbox"/>	<input type="checkbox"/>	<input type="checkbox"/>	0x00																																																																																																																																																																																																																																																																																										
1	<input type="checkbox"/>	<input type="checkbox"/>	<input type="checkbox"/>	<input type="checkbox"/>	<input type="checkbox"/>	<input type="checkbox"/>	<input type="checkbox"/>	<input type="checkbox"/>	0x00																																																																																																																																																																																																																																																																																										
2	<input type="checkbox"/>	<input type="checkbox"/>	<input type="checkbox"/>	<input type="checkbox"/>	<input type="checkbox"/>	<input type="checkbox"/>	<input type="checkbox"/>	<input type="checkbox"/>	0x00																																																																																																																																																																																																																																																																																										
3	<input type="checkbox"/>	<input type="checkbox"/>	<input type="checkbox"/>	<input type="checkbox"/>	<input type="checkbox"/>	<input type="checkbox"/>	<input type="checkbox"/>	<input type="checkbox"/>	0x00																																																																																																																																																																																																																																																																																										
0	<input type="checkbox"/>	<input type="checkbox"/>	<input type="checkbox"/>	<input type="checkbox"/>	<input type="checkbox"/>	<input type="checkbox"/>	<input type="checkbox"/>	<input type="checkbox"/>	0x00																																																																																																																																																																																																																																																																																										
1	<input type="checkbox"/>	<input type="checkbox"/>	<input type="checkbox"/>	<input type="checkbox"/>	<input type="checkbox"/>	<input type="checkbox"/>	<input type="checkbox"/>	<input type="checkbox"/>	0x00																																																																																																																																																																																																																																																																																										
2	<input type="checkbox"/>	<input type="checkbox"/>	<input type="checkbox"/>	<input type="checkbox"/>	<input type="checkbox"/>	<input type="checkbox"/>	<input type="checkbox"/>	<input type="checkbox"/>	0x00																																																																																																																																																																																																																																																																																										
3	<input type="checkbox"/>	<input type="checkbox"/>	<input type="checkbox"/>	<input type="checkbox"/>	<input type="checkbox"/>	<input type="checkbox"/>	<input type="checkbox"/>	<input type="checkbox"/>	0x00																																																																																																																																																																																																																																																																																										

Representation	Description
	<p>Analog Data This section provides the states of the analog data function blocks. If the analog data are disabled the values are grayed out.</p>

Representation	Description																																																																
<div style="display: flex; justify-content: space-between;"> <div style="width: 48%;"> <p>Input Diagnostic</p> <table border="1"> <tr><td>0</td><td></td></tr> <tr><td>1</td><td></td></tr> <tr><td>2</td><td></td></tr> <tr><td>3</td><td></td></tr> <tr><td>4</td><td></td></tr> <tr><td>5</td><td></td></tr> <tr><td>6</td><td></td></tr> <tr><td>7</td><td></td></tr> <tr><td>8</td><td></td></tr> <tr><td>9</td><td></td></tr> <tr><td>10</td><td></td></tr> <tr><td>11</td><td></td></tr> <tr><td>12</td><td></td></tr> <tr><td>13</td><td></td></tr> <tr><td>14</td><td></td></tr> <tr><td>15</td><td></td></tr> </table> </div> <div style="width: 48%;"> <p>Output Diagnostic</p> <table border="1"> <tr><td>0</td><td></td></tr> <tr><td>1</td><td></td></tr> <tr><td>2</td><td></td></tr> <tr><td>3</td><td></td></tr> <tr><td>4</td><td></td></tr> <tr><td>5</td><td></td></tr> <tr><td>6</td><td></td></tr> <tr><td>7</td><td></td></tr> <tr><td>8</td><td></td></tr> <tr><td>9</td><td></td></tr> <tr><td>10</td><td></td></tr> <tr><td>11</td><td></td></tr> <tr><td>12</td><td></td></tr> <tr><td>13</td><td></td></tr> <tr><td>14</td><td></td></tr> <tr><td>15</td><td></td></tr> </table> </div> </div>	0		1		2		3		4		5		6		7		8		9		10		11		12		13		14		15		0		1		2		3		4		5		6		7		8		9		10		11		12		13		14		15		<p>Input Diagnostic and Output Diagnostic These sections provide diagnostics information on the input function blocks and the output function blocks.</p>
0																																																																	
1																																																																	
2																																																																	
3																																																																	
4																																																																	
5																																																																	
6																																																																	
7																																																																	
8																																																																	
9																																																																	
10																																																																	
11																																																																	
12																																																																	
13																																																																	
14																																																																	
15																																																																	
0																																																																	
1																																																																	
2																																																																	
3																																																																	
4																																																																	
5																																																																	
6																																																																	
7																																																																	
8																																																																	
9																																																																	
10																																																																	
11																																																																	
12																																																																	
13																																																																	
14																																																																	
15																																																																	
<div style="border: 1px solid gray; padding: 5px;"> <p>CPU 0 Error</p> <table style="width: 100%;"> <tr> <td>Module</td><td><input type="text"/></td> <td>Error Address</td><td><input type="text" value="000000H"/></td> </tr> <tr> <td>Firmware Version</td><td><input type="text" value="0.0"/></td> <td>Extended Code 0</td><td><input type="text" value="0x00"/></td> </tr> <tr> <td>Error Code</td><td><input type="text" value="0"/></td> <td>Extended Code 1</td><td><input type="text" value="0x00"/></td> </tr> </table> </div>	Module	<input type="text"/>	Error Address	<input type="text" value="000000H"/>	Firmware Version	<input type="text" value="0.0"/>	Extended Code 0	<input type="text" value="0x00"/>	Error Code	<input type="text" value="0"/>	Extended Code 1	<input type="text" value="0x00"/>	<p>CPU 0 Error and CPU 1 Error These sections provide information on detected system errors.</p>																																																				
Module	<input type="text"/>	Error Address	<input type="text" value="000000H"/>																																																														
Firmware Version	<input type="text" value="0.0"/>	Extended Code 0	<input type="text" value="0x00"/>																																																														
Error Code	<input type="text" value="0"/>	Extended Code 1	<input type="text" value="0x00"/>																																																														

Examples

System Status Bits

The System status byte is the first byte of the process data map and provides information on the system status:

Bit 0	Meaning
0	Modular Safety Controller not online.
1	Modular Safety Controller online.

Bit 1	Meaning
0	No diagnostic detected.
1	Diagnostic detected.

Bit 2	Meaning
0	No error detected.
1	Error detected.

Input Status Bits

The number of bits used to represent the state of an Input function block depends on the number of inputs of the function block and the corresponding number of physical inputs of the module.

The state of the input function block reflects the status of its physical inputs. If all the physical inputs are HIGH then the status is set to 1, otherwise it is set to 0.

In addition to the information on the logical state of the input function block, diagnostics information about the Input function blocks is provided in the **Input Diagnostic** section, available via acyclic data.

Example 1

The function blocks `E-STOP`, `LIGHT CURTAIN` and `SWITCH` are used with Modular Safety Controller XPSMCMCP0802•.

The function block `E-STOP` has the lowest index value. It uses two physical inputs of the module. Therefore, the first two bits (b0, b1) are assigned to the function block `E-STOP`.

The function block `LIGHT CURTAIN` has the index value 2. It also uses two physical inputs. Therefore the next two bits (b2, b3) are assigned to the function block `LIGHT CURTAIN`.

The function block `SWITCH` has the index value 3. It uses one physical input, therefore the next bit (b4) is assigned to the function block `SWITCH`.

In the example, no further function blocks are used with the module.

Each input function block uses the number of bits that corresponds to the number of the physical inputs it uses. Of those bits the first bit represents the state of the input function block (0 = FALSE, 1 = TRUE). The next bit or bits are fixed to zero.

If all the physical inputs of a function block are HIGH, then the state of the input function block is set to 1. If at least one of the physical inputs of a function block is LOW then the state of the input is set to 0.

Bit 7	Bit 6	Bit 5	Bit 4	Bit 3	Bit 2	Bit 1	Bit 0
Not used			State of input function block SWITCH is FALSE. The corresponding physical input is LOW.	State of input function block LIGHT CURTAIN is TRUE. The corresponding physical inputs are HIGH.	State of input function block E STOP is TRUE. The corresponding physical inputs are HIGH.		

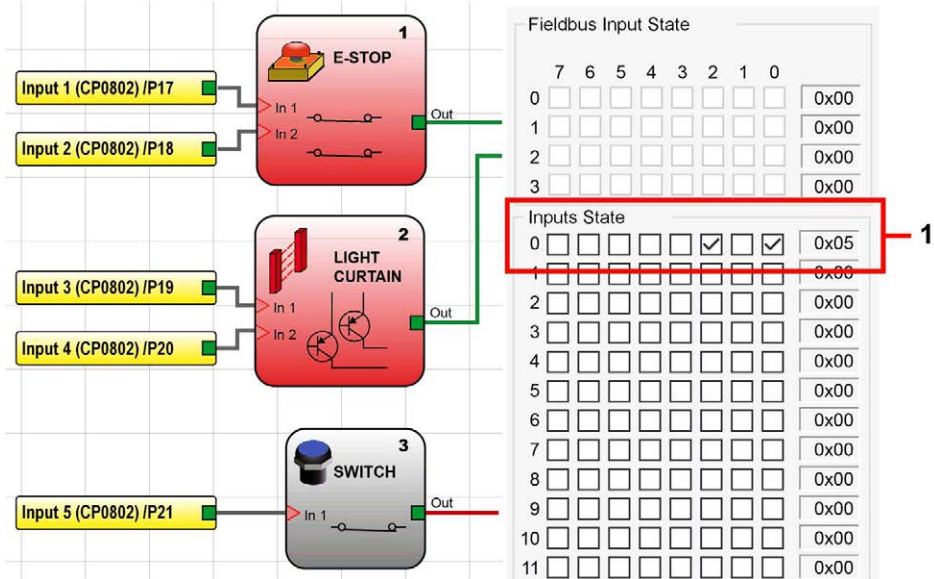

Special Case: Input Function Blocks used for Speed Monitoring Modules XPSMCMEN•

If XPSMCMEN• modules for speed monitoring are used, the corresponding bytes in the Input section of the process data contain additional information and not the input state, as opposed to the bytes for other inputs.

Bits 0 to 3 of the byte represent the first channel, bits 4 to 7 of the byte the second channel. Depending on the type of monitoring (zero speed monitoring, speed range monitoring) and the type of hardware used (encoder and/or proximity sensor), the information in the following table is encoded in the bytes.

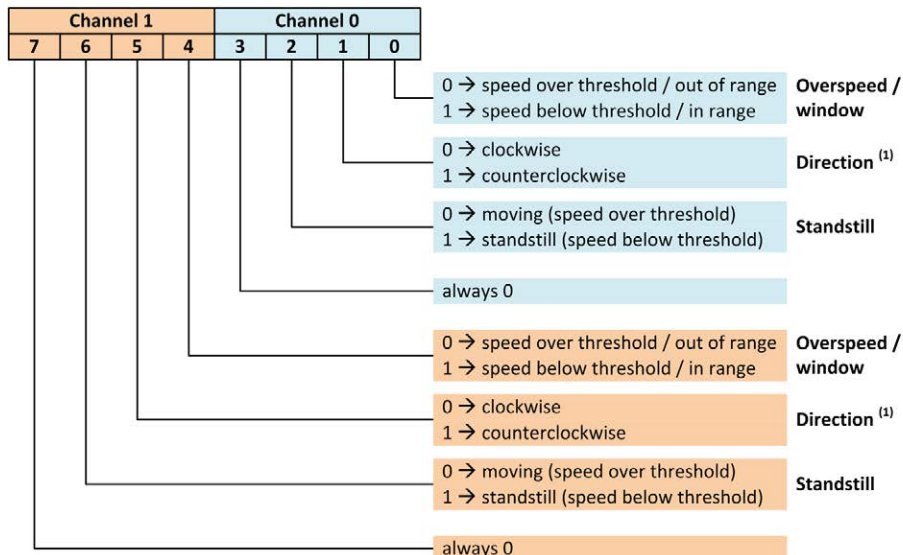

(1) Direction is only indicated if encoders are used. The value of the bit is of no relevance if only proximity sensors are used.

Safety-related Output State Bits

The number of bits used to represent the status of a safety-related output function block depends on the type of safety-related output selected:

- One dual-channel safety-related output is represented with 1 bit.
- One single channel safety-related outputs is represented with 1 bit.
- Two single channel safety-related outputs combined in a dual channel are represented with 2 bits.

In addition to the information on the logical state of the safety-related output function block, diagnostics information about the safety-related output function blocks is provided in the **Output Diagnostic** section, available via acyclic data.

Example 2

Two dual-channel output function blocks OSSD are used with controller XPSMCMCP0802• (see the following figure):

- Bit 0 is assigned to the function block safety-related output 1 because it has the lowest index value.
- Bit 1 is assigned to the function block safety-related output 2.

The bit assigned to a safety-related output function block represents the state of the output function block (0 = FALSE, 1 = TRUE). If the bit of a safety-related output function block is 1, the physical outputs of the module to which this function block is assigned are HIGH. If the bit of a safety-related output function block is 0, at least one of the physical outputs of the module to which this function block is assigned is LOW.

Graphical representation of byte 0 of data block states of safety-related output (byte 19 of output data map):

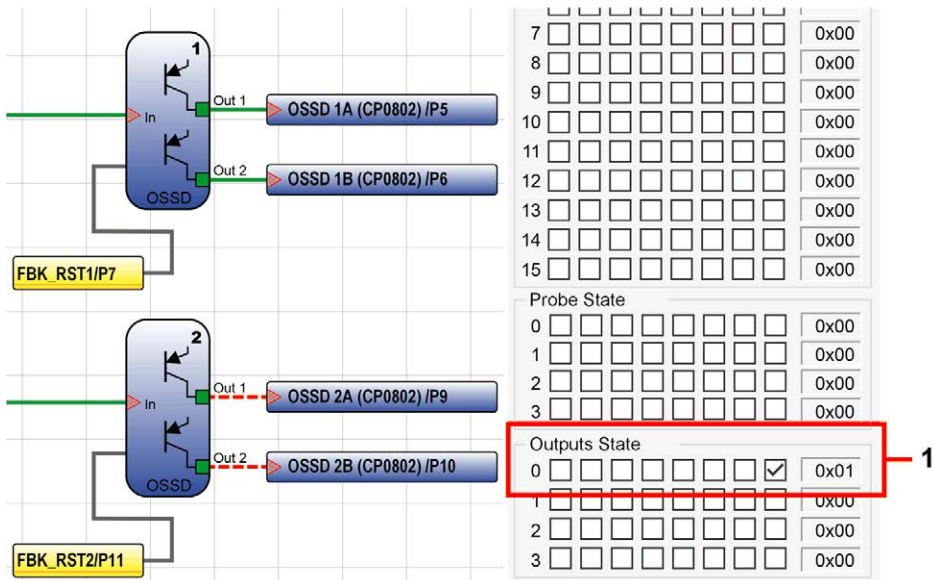

Bit 7	Bit 6	Bit 5	Bit 4	Bit 3	Bit 2	Bit 1	Bit 0
Not used						State of output function block safety-related output 2 is FALSE. The corresponding physical outputs are LOW.	State of output function block safety-related output 1 is TRUE. The corresponding physical outputs are HIGH.

If diagnostics information is available on an output function block, the first byte of the data block with the diagnostics information (byte 21 of the output data map) contains the index number of the output function block without this offset. For example, the index number 2 of an output function block in SoSafe Configurable corresponds to the number 93 in the output data map.

The diagnostics code for an input function block or an output function block is contained in byte 22 of the output data map. The corresponding error message is displayed in BUS Configurator.

If no error has been detected, no diagnostic information is available and the value of byte 22 is 128.

Diagnostics Information on the Input and Output Function Blocks

The data regarding diagnostics information of the input function blocks and the safety-related output functions blocks are available as acyclic data. Two bytes are assigned to a single block.

The first byte contains the index number that identifies the function block, while the second byte contains the diagnostic information of the function block. The index number of a function block corresponds to the number shown in SoSafe Configurable.

There are two sections in the BUS Configurator to show the diagnostics information. A maximum of 16 diagnostics for both input and safety-related output blocks are available. If more than 16 function blocks reports diagnostics only the first 16 are shown.

Input Diagnostic		Output Diagnostic	
0		0	
1		1	
2		2	
3		3	
4		4	
5		5	
6		6	
7		7	
8		8	
9		9	
10		10	
11		11	
12		12	
13		13	
14		14	
15		15	

1
2

- 1** Diagnostics information on input function blocks
- 2** Diagnostics information on output function blocks

The index number is also shown on the function blocks in SoSafe Configurable.

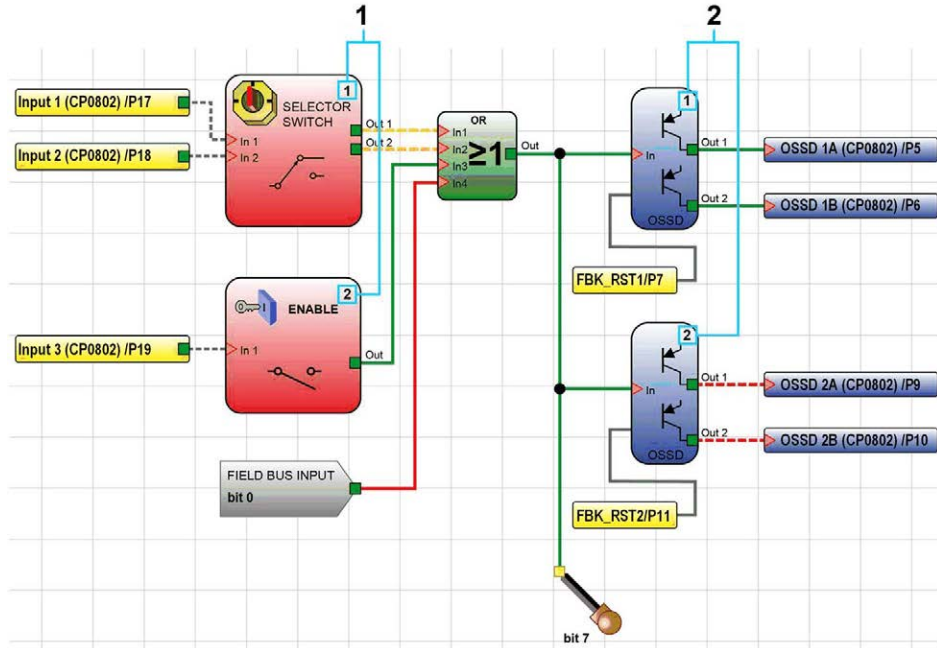

Configuration Example in SoSafe Configurable and Representation in BUS Configurator

Configuration Example in SoSafe Configurable

The table below (*see page 119*) the following two screenshots provides detailed descriptions of the numbered items in the screenshots and allows you to correlate these items with the same items as represented in SoSafe Configurable (*see page 117*) and in BUS Configurator.

SoSafe Configurable:

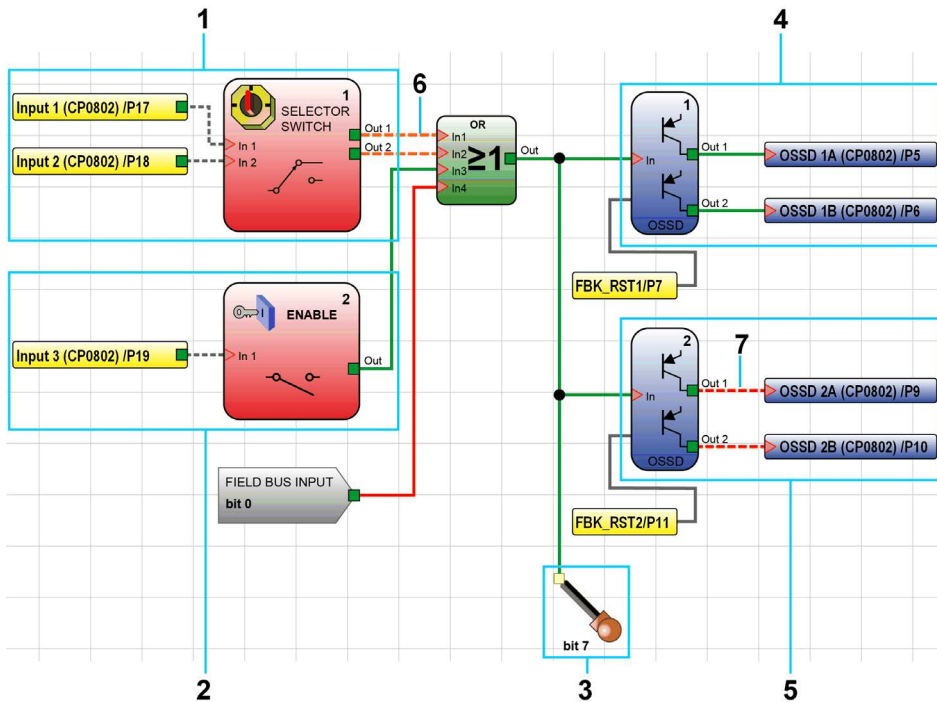

BUS Configurator:

1 CPU 0 Error
 Module:
 Firmware Version: 0.0
 Error Code: 0
 Error Address: 000000H
 Extended Code 0: 0x00
 Extended Code 1: 0x00

2 CPU 1 Error
 Module:
 Firmware Version: 0.0
 Error Code: 0
 Error Address: 000000H
 Extended Code 0: 0x00
 Extended Code 1: 0x00

3 Fieldbus Input State

	7	6	5	4	3	2	1	0	
0									0x00
1									0x00
2									0x00
3									0x00
4									0x00
5									0x00
6									0x00
7									0x00
8									0x00
9									0x00
10									0x00
11									0x00
12									0x00
13									0x00
14									0x00
15									0x00

4 Inputs State

	7	6	5	4	3	2	1	0	
0									0x00
1									0x00
2									0x00
3									0x00
4									0x00
5									0x00
6									0x00
7									0x00
8									0x00
9									0x00
10									0x00
11									0x00
12									0x00
13									0x00
14									0x00
15									0x00

5 Outputs State

	7	6	5	4	3	2	1	0	
0									0x00
1									0x00
2									0x00
3									0x00

6 Input Diagnostic

	Code	Description
0	7	Input: 1 - Code: 7
1		Selector switch inconsistent
2		
3		
4		
5		
6		
7		
8		
9		
10		
11		
12		
13		
14		
15		

7 Output Diagnostic

	Code	Description
0	2	OSSD: 2 - Code: 2
1		Waiting Restart
2		
3		
4		
5		
6		
7		
8		
9		
10		
11		
12		
13		
14		
15		

Bus Module: CAN (CANOpen) Firmware Version: 2.12 Schematic CRC: D557H Master Status (FW 5.1): ●

Configuration Example in SoSafe Configurable and Representation in BUS Configurator

The following table provides detailed descriptions of the numbered items in the configuration example in SoSafe Configurable (*see page 117*) and the corresponding representation in BUS Configurator.

Number	Description
1	The input function block <code>SELECTOR_SWITCH</code> with index 1 is connected to physical inputs 1 and 2 of XPSMCMCP0802*. Since the input function block has two inputs, bits b0 and b1 of byte 0 of the Inputs State section are assigned to this function block. None of the physical inputs are connected to 24 V. The logical state of the input function block <code>SELECTOR_SWITCH</code> is FALSE. In BUS Configurator, this is indicated by the fact that none of the checkboxes representing the bits b0 and b1 are checked. In SoSafe Configurable, this is indicated by the dashed orange line (incorrect connection). At least one of the corresponding physical inputs of XPSMCMCP0802* is LOW.
2	The input function block <code>ENABLE</code> with index 2 is connected to physical input 3 of XPSMCMCP0802*. Since the input function block has one input, bit b2 of byte 1 of the Inputs State section is assigned to the function block. The logical state of the input function block <code>ENABLE</code> is TRUE. In BUS Configurator, this is indicated by the fact that the checkbox representing the bit b2 is checked. In SoSafe Configurable, this is indicated by the green line (connected). The corresponding physical input of XPSMCMCP0802* is HIGH.
3	The logical state of the probe assigned to bit 7 is TRUE. In BUS Configurator, this is indicated by the fact that the checkbox representing the bit b7 of byte 1 is checked. In SoSafe Configurable, this is indicated by the green line.
4	The output function block Safety-related Output 1 with index 1 is connected to physical outputs 1A and 1B of XPSMCMCP0802*. Bit b0 of byte 1 of the Outputs State section is assigned to this function block. The logical state of the output function block Safety-related Output is TRUE. In BUS Configurator, this is indicated by the fact that the checkbox representing the bit b0 is checked. In SoSafe Configurable, this is indicated by the green line (connected). The corresponding physical outputs 1A and 1B of XPSMCMCP0802* are HIGH.
5	The output function block Safety-related Output with index 2 is connected to physical outputs 2A and 2B of XPSMCMCP0802*. Bit b1 of byte 0 of the Outputs State section is assigned to this function block. The restart signal is not activated. The logical state of the output function block Safety-related Output is FALSE. In BUS Configurator, this is indicated by the fact that the checkbox representing the bit b1 is not checked. In SoSafe Configurable, this is indicated by the dashed red line (incorrect signal). The corresponding physical outputs 2A and 2B of XPSMCMCP0802* are LOW.
6	The Input function block <code>SELECTOR_SWITCH</code> with index number 1 reports a diagnostic since none of the physical inputs are connected to 24V. The first field in the Input Diagnostic section display the index number of the Input function block (1) and the second field shows the diagnostics message. In SoSafe Configurable, diagnostics information is graphically represented on the Monitor screen (<i>see Modular Safety Controller, Library and Programming Guide</i>), not on this screen.
7	The output function block Safety-related Output with index 1 reports a diagnostic since the restart signal is not activated. The first field in the Output Diagnostic section displays the index number of the output function block (2) and the second field shows the diagnostics message. In SoSafe Configurable, diagnostics information is graphically represented on the Monitor screen (<i>see Modular Safety Controller, Library and Programming Guide</i>), not on this screen.

XPSMCMCO0000• Fieldbus Modules Compatibility Chart

Firmware Versions

The Modular Safety Controllers XPSMCMCP0802• and XPSMCMC10804• work with every XPSMCMCO0000• device, either the one with firmware version 2.x or the previous firmware versions 1.8/1.9.5, but the available process data is different.

The process data mapping of the XPSMCMCO0000• follows the fieldbus version: old mapping as described in the previous documentation for the firmware version 1.8/1.9.5, or new mapping as described in the present document with firmware version 2.x.

The XPSMCMCO0000• with firmware version 2.x works with either XPSMCMCP0802• or XPSMCMC10804• and use the new process data mapping described in the present document.

The XPSMCMCO0000• with firmware version 2.x can also use the type of mapping of firmware versions 1.8/1.9.5 if it is set to backward compatibility mode during the configuration.

If an XPSMCMC10804• program uses a limited number of resources that fits in the old mapping, then the XPSMCMCO0000• 1.8/1.9.5 can be used. Otherwise the XPSMCMC10804• does not run the program unless an XPSMCMCO0000• 2.x is connected.

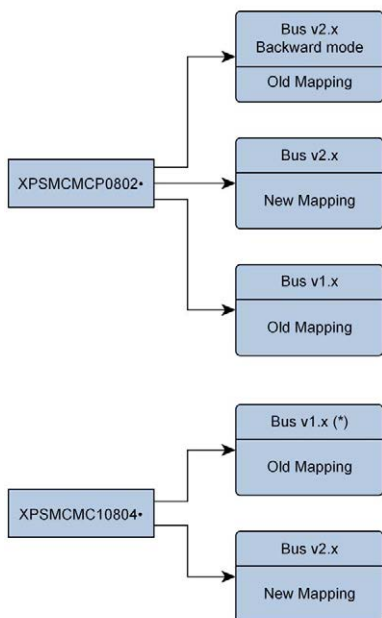

* This combination is only available as long as the XPSMCMC10804• application is not exceeding the XPSMCMCP0802• application capabilities (for instance, does not use more than 8 safety-related function blocks or 16 fieldbus probe function blocks or 8 fieldbus inputs function blocks).



C

characteristics

- XPSMCMCO0000COx, 33
- XPSMCMCO0000ECx, 46
- XPSMCMCO0000EIx, 57
- XPSMCMCO0000EMx, 75
- XPSMCMCO0000MBx, 65
- XPSMCMCO0000PBx, 84

F

fieldbus

- XPSMCM•, 18
- XPSMCMCO0000CO•, 19
- XPSMCMCO0000EC•, 19
- XPSMCMCO0000EI•, 19
- XPSMCMCO0000EM•, 19
- XPSMCMCO0000MB•, 19
- XPSMCMCO0000PB•, 19

fieldbus modules

- module characteristics, 31

M

mapping information

- XPSMCMCO0000COx, 35
- XPSMCMCO0000ECx, 48
- XPSMCMCO0000EIx, 59
- XPSMCMCO0000EMx, 77
- XPSMCMCO0000MBx, 67
- XPSMCMCO0000PBx, 86

module characteristics

- fieldbus modules, 31

X

XPSMCM•

- fieldbus, 18

XPSMCMCO0000CO•

- fieldbus, 19

- XPSMCMCO0000COx
 - characteristics, 33
 - mapping information, 35
- XPSMCMCO0000EC•
 - fieldbus, 19
- XPSMCMCO0000ECx
 - characteristics, 46
 - mapping information, 48
- XPSMCMCO0000EI•
 - fieldbus, 19
- XPSMCMCO0000EIx
 - characteristics, 57
 - mapping information, 59
- XPSMCMCO0000EM•
 - fieldbus, 19
- XPSMCMCO0000EMx
 - characteristics, 75
 - mapping information, 77
- XPSMCMCO0000MB•
 - fieldbus, 19
- XPSMCMCO0000MBx
 - characteristics, 65
 - mapping information, 67
- XPSMCMCO0000PB•
 - fieldbus, 19
- XPSMCMCO0000PBx
 - characteristics, 84
 - mapping information, 86