

# LED GARDEN LAMP

 Product&Family Code: **076 010 0005**
**HURMA**

Dark Grey

## Technical Drawing

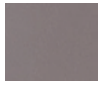
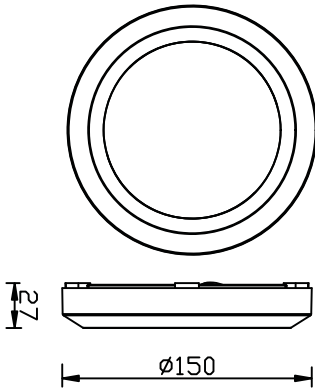

## Photometric Diagram

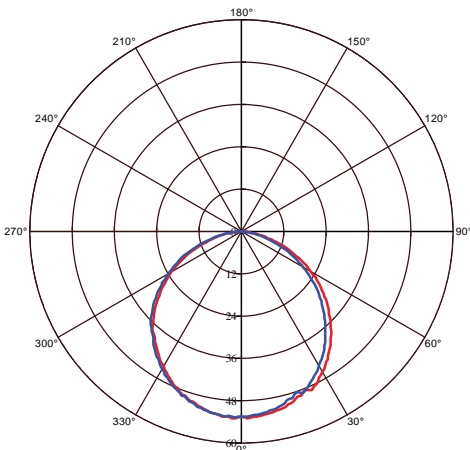

C0 Plane beam angle(50%):110.4(DEG) C90 Plane beam angle(50%):109.6(DEG)

Technical Data	
Voltage (V)	100-240V
Product Wattage (W)	5
Equivalence with incandescent lamp(W)	40
Colour Render Index (Ra)	>Ra70
Colour Temperature (K)	4200K
Materials	ABS
Protection Class	II
Dimmable	No
EEI	A to A++
Warm-up time up to 60 %of the full light output	Instant Full Light
Luminous Flux (lm)	270
Luminous Efficacy (lm/W)	54
Rated Life (hrs) ⌚	30.000
IP Rating	65
Power Factor	>0.5
Beam Angle	105°
Starting Time	<0.2s
Number of ON-OFF cycling	x15.000

## Applications

- Designed Outdoor Applications: Hotel, home lighting, recreation place, supermarket, office building.



## Features

- High Lumen and CRI, Good quality & Constant Current driver.
- High heat dissipation, low carbon and environmental protection.
- SMD LED Lamp Base.
- Innovative Design of Assembly Structure

