

**Manuelle Spülzeit-Einstellung**  
**Manual setting for flush time**  
**Réglage manuel de la durée de rinçage**  
**Regolazione manuale della durata di risciacquamento**

**1**

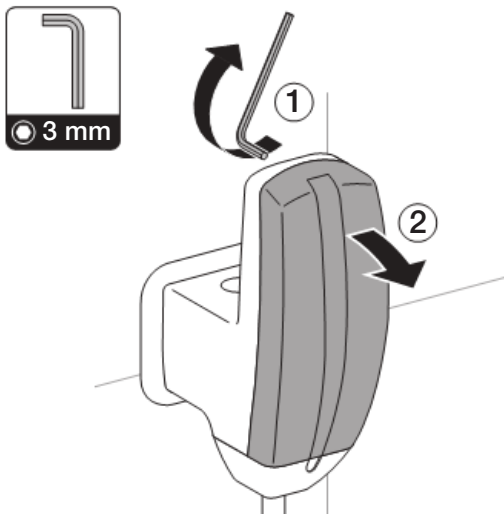

**2**

Stecker der Elektronik von der Batterie für mindestens 20 s entfernen.  
 Remove the electronics plug from the battery for at least 20 s.  
 Retirer le connecteur de l'électronique de la pile pour une durée d'au moins 20 s.  
 Staccare la spina dell'elettronica dalla batteria per almeno 20 s.

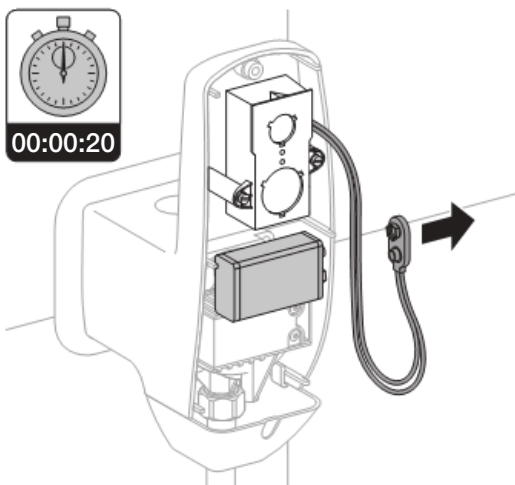

**3**

Nach dem Wiederherstellen der Stromzufuhr innerhalb von 5 s die Hand im Abstand von ca. 5 cm vor die Elektronik halten → Kontrolllampe (LED) leuchtet.  
 Within 5 s after reconnecting the power, hold your hand in front of the electronics at a distance of approx. 5 cm → Control lamp (LED) lights up.  
 Après avoir rétabli l'alimentation en courant placer une main dans les 5 s qui suivent devant l'électronique (distance env. 5 cm) → La lampe témoin (DEL) s'allume.  
 Dopo il ricollegamento all'alimentazione elettrica, mettere una mano davanti all'elettronica (distanza ca. 5 cm) entro 5 s → La spia luminosa (LED) si accende.

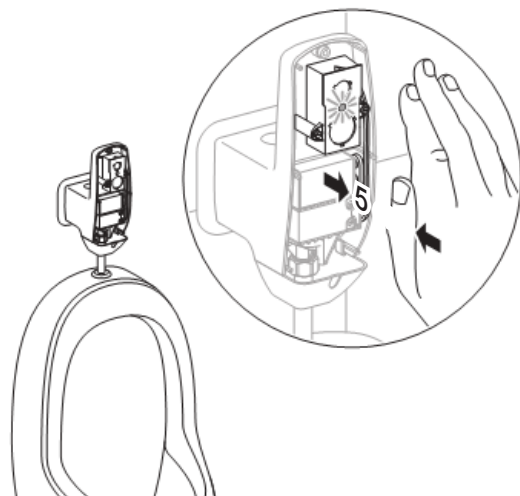

**4**

Steuerung löst eine Spülung aus. Die neue Spülzeit dauert so lange, wie die Hand während der Spülung vor der Steuerung gehalten wird (3 - 15 s).  
 Control triggers a flush. The new flush duration corresponds to the length of time for which the hand is held in front of the control during flushing (3 - 15 s).  
 Le contrôle déclenche un rinçage. Le rinçage dure maintenant aussi longtemps que votre main se trouve devant le contrôle (3 à 15 s).  
 Il comando dà inizio ad un risciacquamento. La nuova durata di risciacquamento è definita dal tempo durante il quale la mano si trova davanti al comando (tra 3 e 15 s).

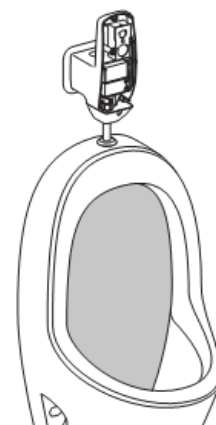

- 5** Die Kontrolleuchte zeigt durch Blinken die neu eingestellte Spülzeit an. (1 x Blinken = 1 s)  
Bei nicht optimal erreichter Spülzeit → Vorgang wiederholen! (2 - 5)  
The control lamp flashes to indicate the new flush duration set. (1 flash = 1 s)  
If the flush duration is not yet ideal → Repeat procedure! (2 - 5)  
La lampe témoin indique la nouvelle durée de rinçage par un clignotement. (1 clignotement = 1 s)  
Lorsque la durée de rinçage n'est pas optimale → répéter les opérations! (2 à 5)  
La spia luminosa lampeggia per indicare la nuova durata di risciacquamento. (1 lampeggiamento = 1 s)  
Se la durata di risciacquamento non è ottima → ripetere le operazioni! (2 - 5)

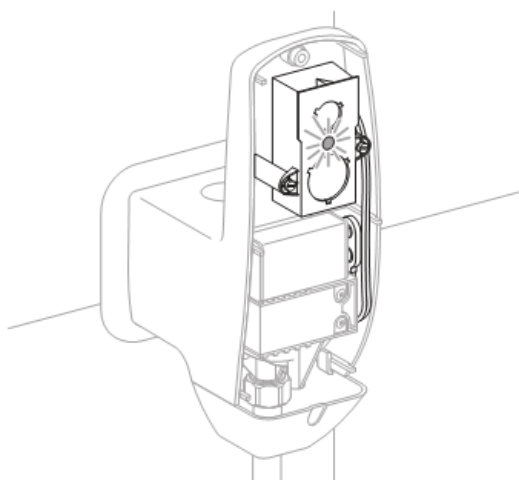

## Service

- Filter reinigen**  
**Clean filter**  
**Nettoyer le filter**  
**Pulire il filtro**

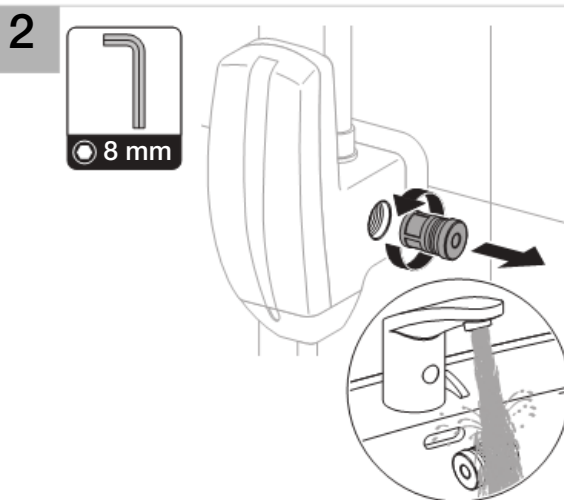
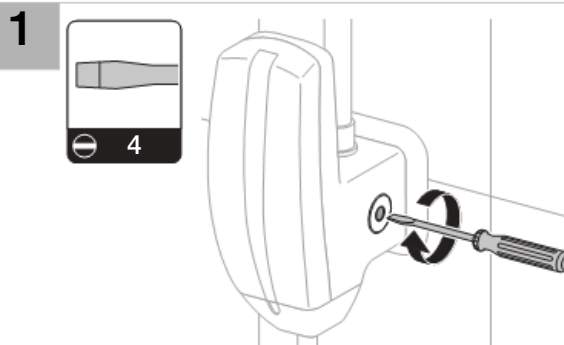

Sichtfenster wechseln  
Change viewing window  
Changer optique  
Sosituire l'apertura ottica

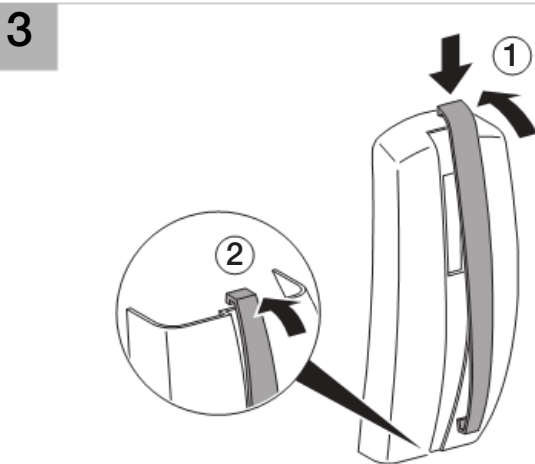
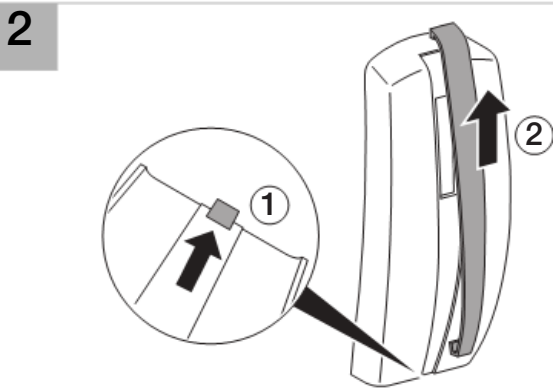
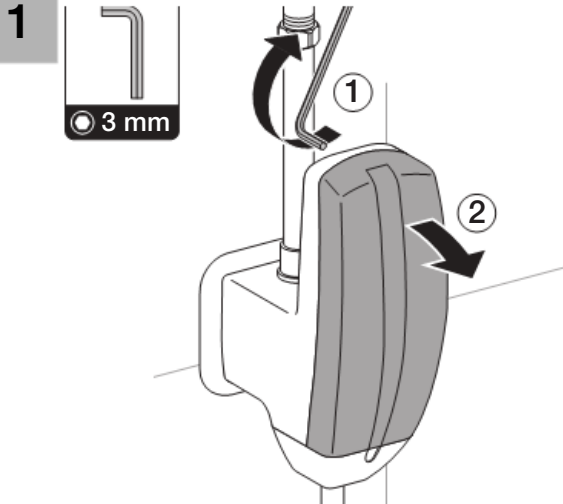

Geberit International AG  
Schachenstrasse 77  
CH-8645 Jona  
[www.geberit.com](http://www.geberit.com)  
[dokumentation@geberit.com](mailto:dokumentation@geberit.com)