

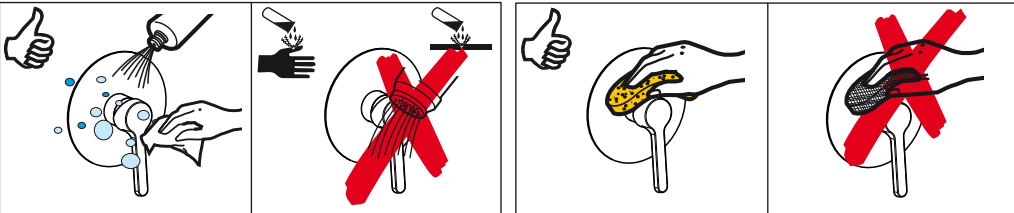

## Ricambi / Spare parts

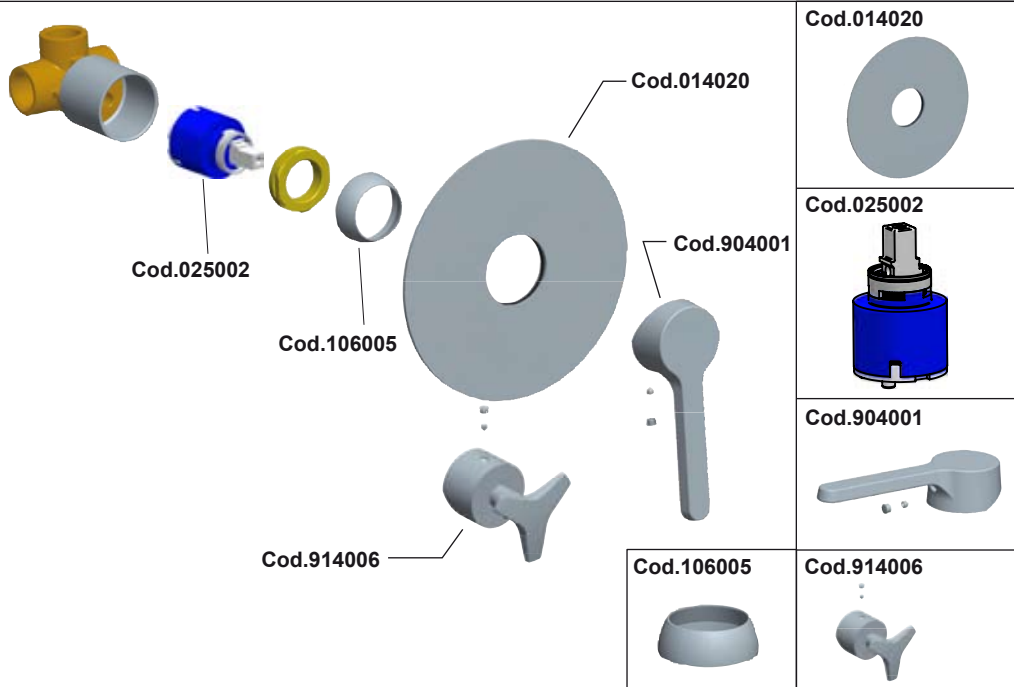

## MANUTENZIONE E PULIZIA

Per una corretta manutenzione e pulizia di questo prodotto, raccomandiamo alcuni semplici accorgimenti:

- Utilizzare **detergenti neutri**, spruzzando il prodotto direttamente su un panno morbido onde evitare infiltrazioni
- Evitare **sempre** il contatto con prodotti acidi o abrasivi
- **Risciacquare bene** con abbondante acqua per eliminare eventuali residui ed asciugare sempre con un panno morbido
- Effettuare una **pulizia periodica** al fine di prevenire le formazioni calcaree

La BELLOSTA CARLO & C. non è RESPONSABILE di danni derivati dall'utilizzo di prodotti impropri per la pulizia.

### MADE IN ITALY

Questo prodotto è stato realizzato interamente in Italia con l'utilizzo di materie prime di altissima qualità

**DESIGN**  
Piet Billekens

## MAINTENANCE AND CLEANING

For a proper maintenance and cleaning, we recommend the following:

- Use **natural detergents**, avoiding to spray directly on taps to avoid residual infiltration
- **Avoid** contact with acid or abrasive products
- **Rinse** with water and **always dry** with a clean cloth to avoid residue of detergent
- Perform a **periodic cleaning** to prevent limestone deposits

BELLOSTA CARLO & C. cannot be held responsible for damages due to an improper use of detergents.

### MADE IN ITALY

This product has been entirely manufactured in Italy, by top quality raw materials.



Engineered by POLITEKNE - 07/05 ISO 9001:2000 - SCQ

# ELITE

DESIGN Piet Billekens

## Istruzioni di installazione / Installation instruction

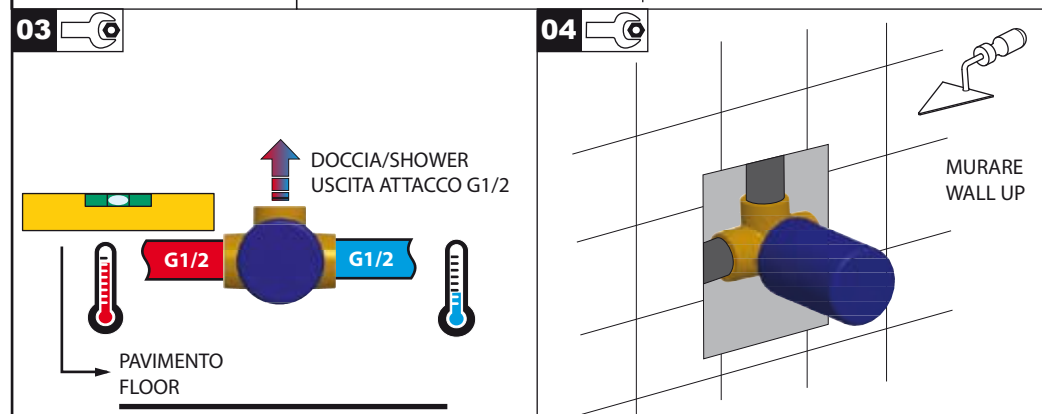
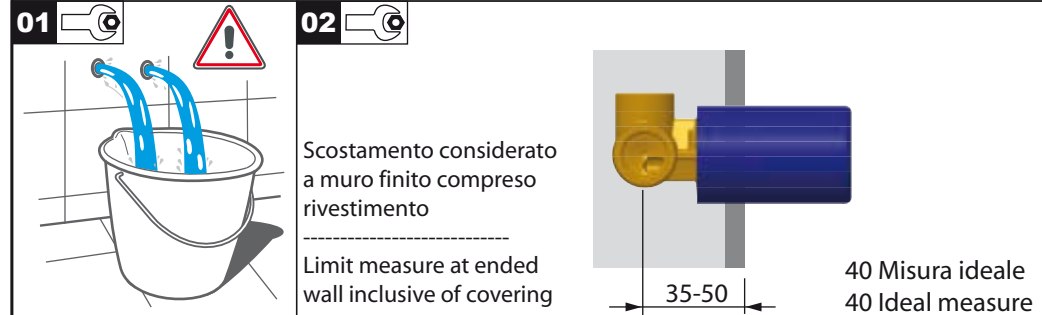
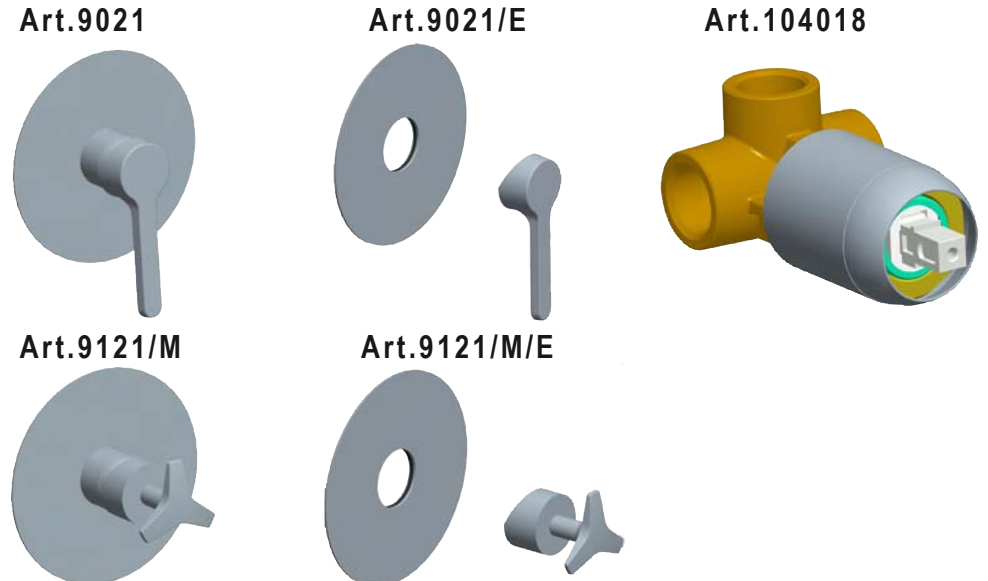

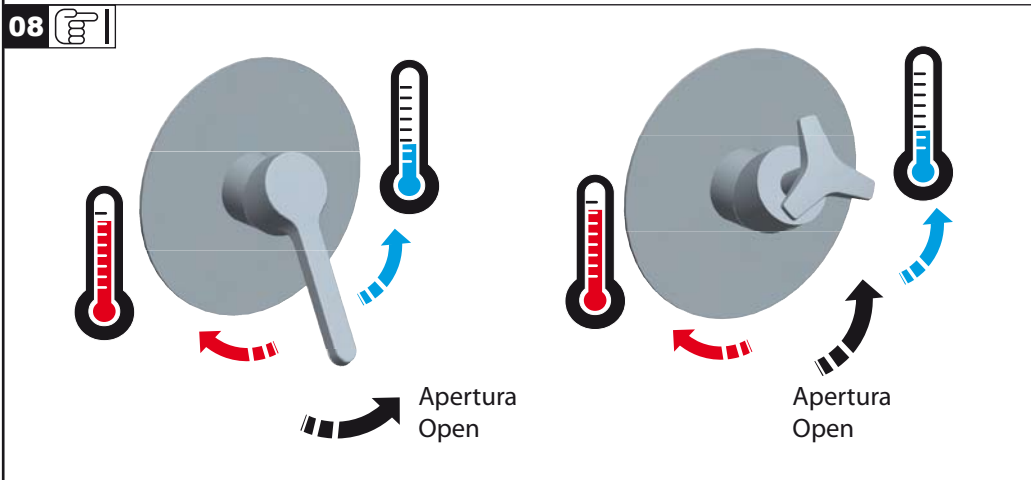
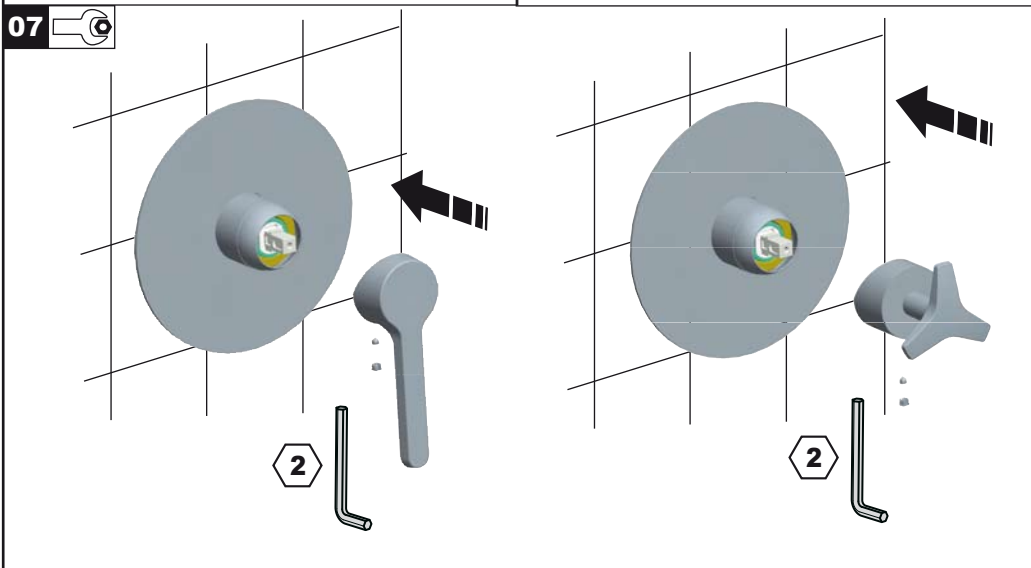
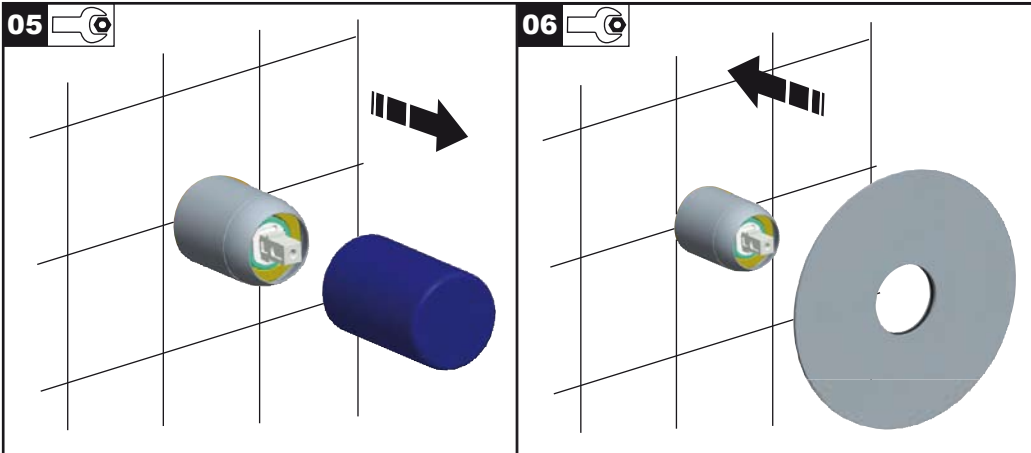

 **Sostituzione cartuccia / Cartridge replacement**

Prima di iniziare le operazioni di sostituzione della cartuccia, assicurarsi che l'acqua dell'impianto principale sia chiusa e che la cartuccia sia svuotata da residui d'acqua.

Before starting replacement cartridge, ensure that water system has been turned off and empty remaining water.

