



Name: MOS - 03

Design: Joana Bover / 2008

Typology: Pendant lamp

Environment: Indoor

Technical description

Pendent lamp releasing diffused light through a translucent shade of hand wrapped polyester blend ribbon. Light passes through a white opal glass diffuser, with white, cream or red translucent ribbon options for the shade. The iron structure has a satin nickel finish, available with a transparent PVC wire connection, as well as adjustable or safety tensor wires. Various tensor wires are available: 1.5, 3, and 5 mt + terminal.

Lamps description

 Earthing: compulsory

 Ready for mounting on normally flammable surface

 6 x 70 W Classic A ECO E-27

 6 x 30 W E-27

Voltage: 230V~50Hz

 1 Box 125 x 125 x 110 cm

Vol.: 1,7188 m³

Weight: 30 kg

Certifications:  

Ref

Finishings

224P621 White translucent ribbon

224P625 Cream translucent ribbon

224P626 Red translucent ribbon

Diffuser white opal glass included

Satin nickel

Transparent connection

Adjustable tensor wire

Safety tensor wire

Customizable

Measures

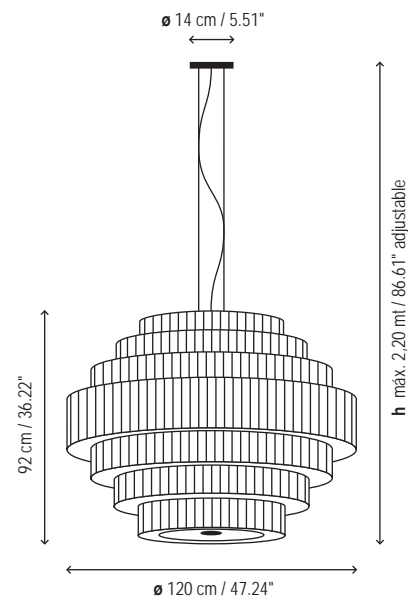

Photometrics

Project information

Project name:

Approved by:

Fixture type:

Date:

Location:

Prepared by:

Comments:

Prepared for:

MOS - 01

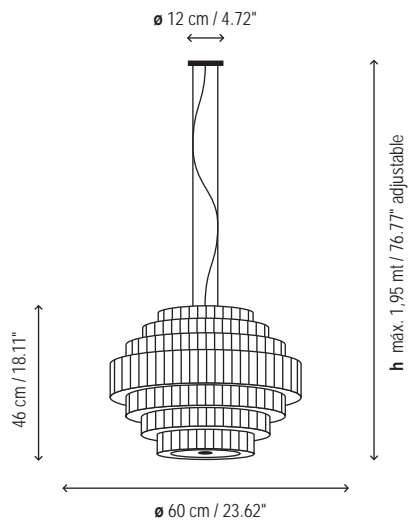

MOS - 02

