



**Name:** INARI TABLE

**Design:** Joana Bover / 2011

**Typology:** Pendant lamp

**Environment:** Indoor

**Technical description:**

Table lamp with iron structure coated in shiny chrome or satin nickel coated finish. Lamp shade is opal crystal blown into a globe, with only the middle section being utilized. Opal crystal undergoes sand blast treatment, which lends an opaque, frosty appearance to the glass. Matte glass upper diffuser is included with the fixture, lower iron diffuser with chrome or nickel coating is also included. Consult sales team for possible dimming options. Only product finishing is customizable.



**Lamps description**

 Earthing: excluded

 3 x 42 W Classic P ECO E-27

 3 x 18 W E-27

**Voltage:** 230V~50Hz

**2 boxes:**  1 Box 55 x 55 x 75 cm

**Vol.:** 0,2269 m<sup>3</sup> **Weight:** 12 kg

 1 Box 60 x 60 x 40 cm

**Vol.:** 0,1440 m<sup>3</sup> **Weight:** 7 kg

**Certifications:**  

**Ref** **Finishings**

2220205 nickel-opal glass

2220206 chrome-opal glass

Lamp with incorporated dimmer

**Not Customizable**

**Measures**

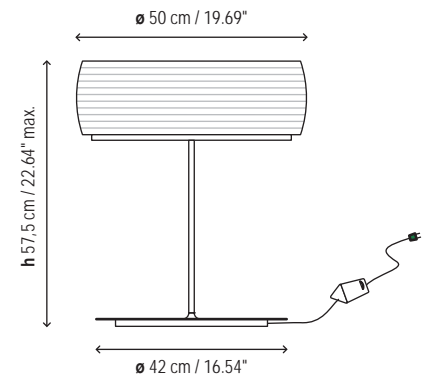

**Project information**

Project name:	Approved by:
Fixture type:	Date:
Location:	Prepared by:
Comments:	Prepared for:

**Photometrics**