



Cooker hob Milanello Copper 5F - 7682 008

Cooker hobs

Code: 7682 008



DETAILS

Coloring	Copper
Finish	PVD
Material	AISI 304 stainless steel
Texture	Satin
Supply	220-240 V; 50.60 Hz
Edge/Installation Type	Flush-mount Top-mount
Dimensions	803x513 mm
Base size	80cm
Heating element	Five burners

Built-in hole	View technical data sheet (for all Flush-mount / Top-mount models and Under-mount models)
Grids	Cast iron grids and enamelled burner covers
Total power	10.250 W
Auxiliary	1.000 W
Semirapid	3x1.750 W
Triple crown	4.000 W
Safety	Safety valve with quick-acting thermocouple
Ignition	Electric ignition under knob
Gas type	Tested for installation with natural gas, LPG nozzle set included.
Type	Gas Hob

FEATURES

Copper	The Copper finish is obtained by treating steel with a physical process called PVD (Physical Vacuum Deposition) which deposits particles of noble metals on the surface. The result is a unique and refined aesthetic effect, and an improvement of the mechanical properties of the steel which is more resistant to impact and scratches.
Cast iron grids	Cast-iron is the ideal material for an hob grid, this due to the manifold properties characterising it: high heat capacity that improves cooking performance; high weight and stability that improve safety; sturdiness that preserves the hob's original aspect over time; easy cleaning.

Precise Power

Flat burners with PrecisePower system: great control in flame-settings. Maximum precision in regulating the flame, thanks to the 10 pre-set levels of the PrecisePower system. And as a benefit, the nice and ultra-low look of the new Flat burners.

Safe cooking

All Foster cooker hobs are equipped with safety valves. They shut off the gas supply very quickly if the flame accidentally goes out.

Special burners

Many Foster hobs are equipped with special burners, with two or three rings of fire that greatly increase the power delivered and the heated surface. In the DUAL models the two fire crowns also have independent ignition, making these burners perfect for both intensive and delicate cooking.

Ultra-flat hob

Design meets functionality in the the ultra-flat models. Elegant grids that form a generously sized overall surface.

Under-knob ignition

The utmost freedom of movement with electronic under-knob ignition, a common feature of all models that allows a one-hand ignition of the burner.

TECHNICAL DATA

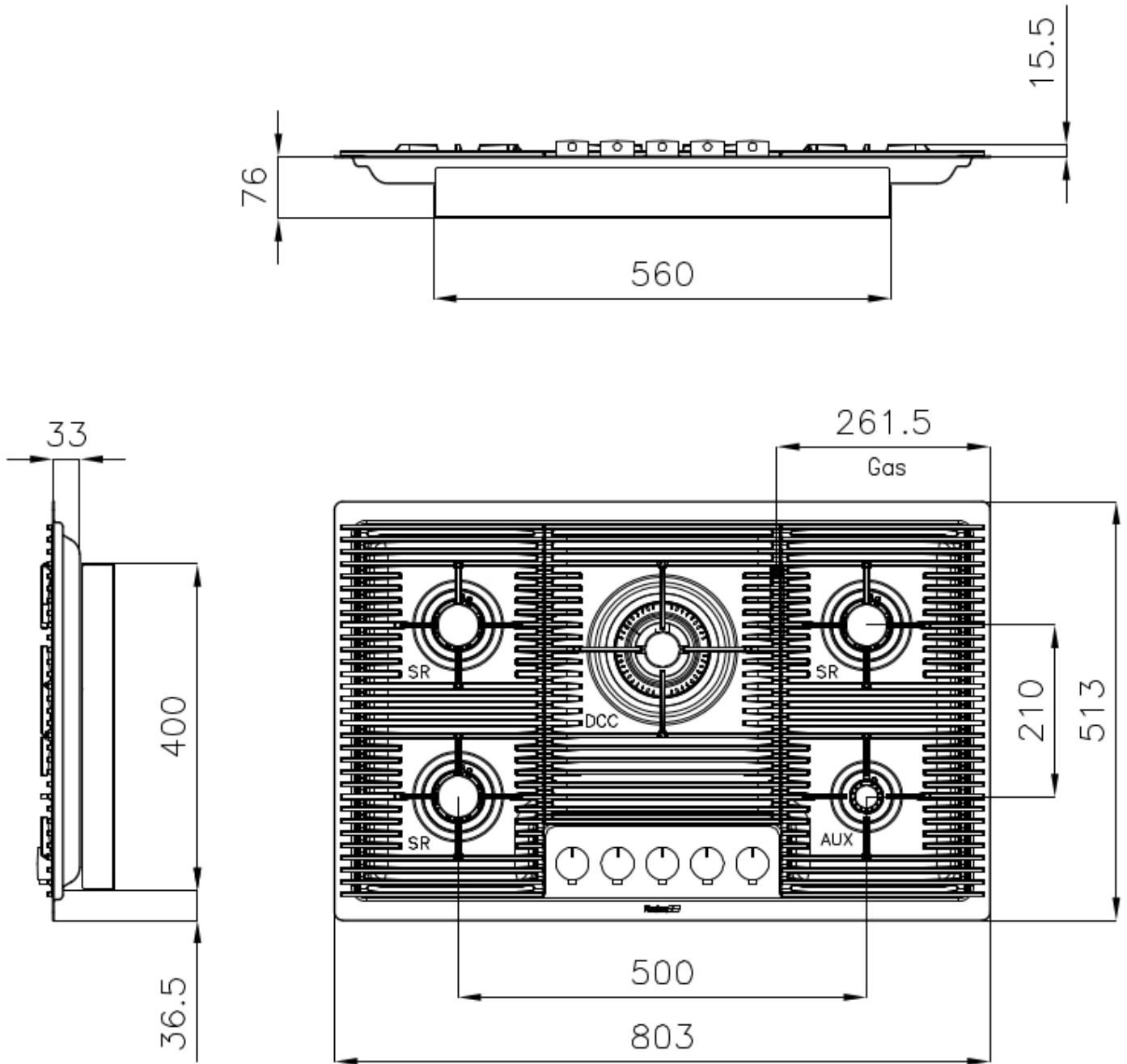

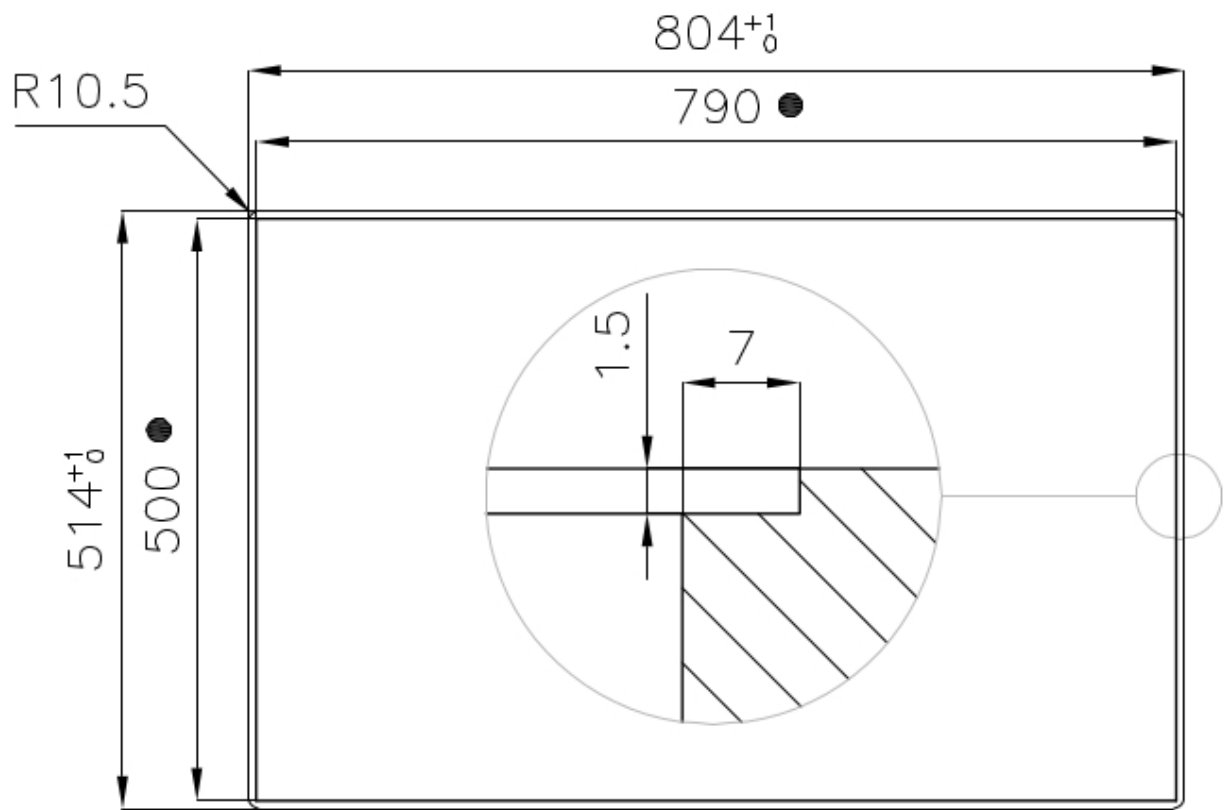

- Built-in cut out for FTS – Foratura per installazione FTS

OPTIONAL ACCESSORIES



Cast iron wok support 9601 727

RECOMMENDED PAIRINGS



Sink Milanello Copper workstation 1034 058



Sink Milanello Copper Workstation 1034 858



Sink Phantom Base Copper - 5557 148



Sink Phantom Edge Copper - 4157 018