

INSTALLATION MANUAL

MONTAGEANLEITUNG
INSTRUCTIONS DE MONTAGE
ISTRUZIONI PER IL MONTAGGIO

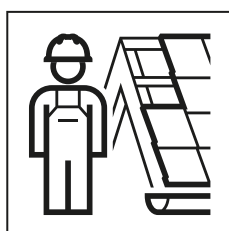

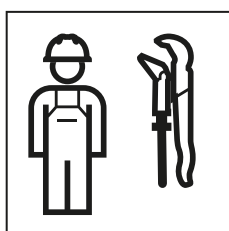
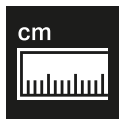

359.635.00.1

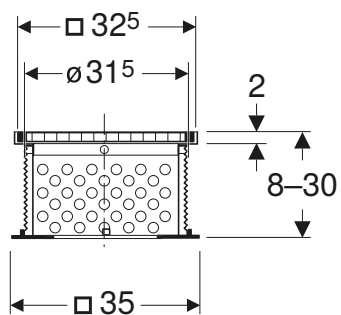

✓

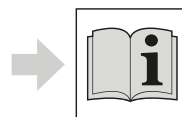

Installation Notes
Geberit Pluvia 967.544.00.0

1

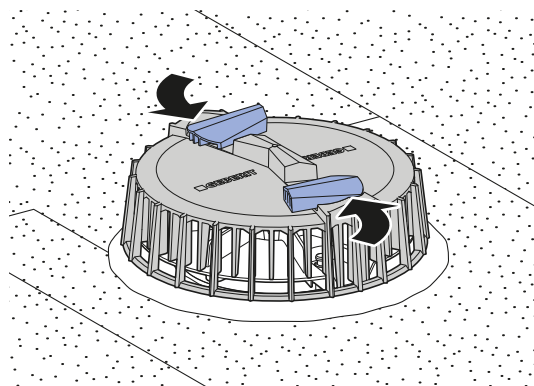

2

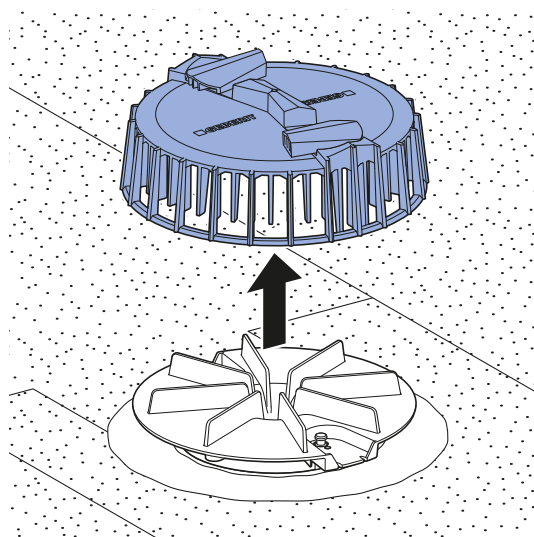

3

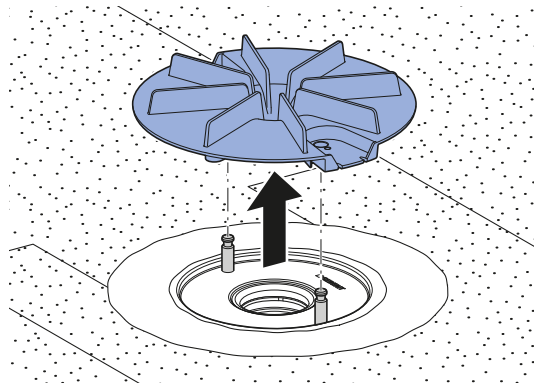

4

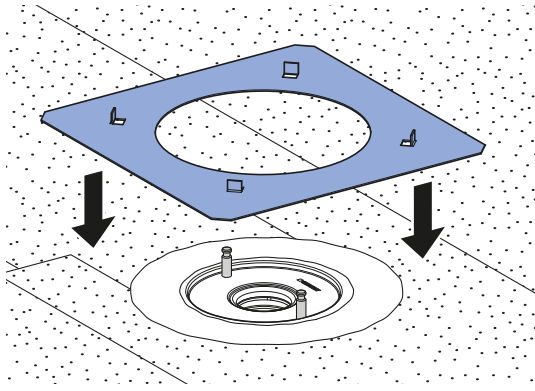

5

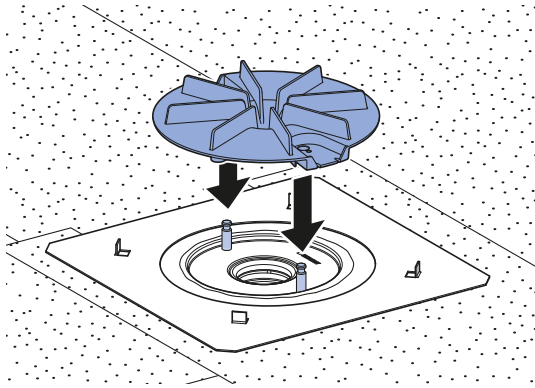

6

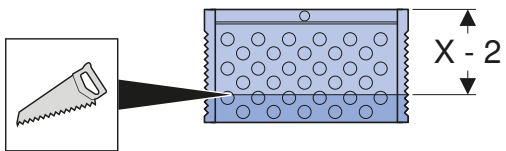
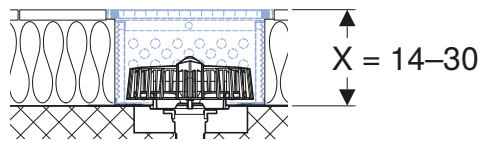

i

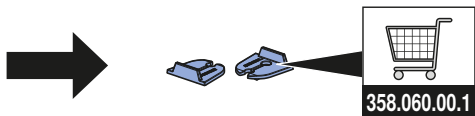
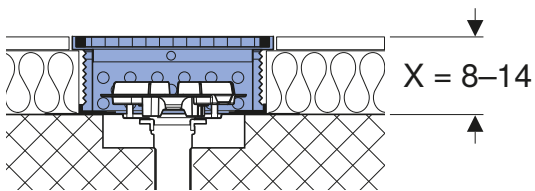

7

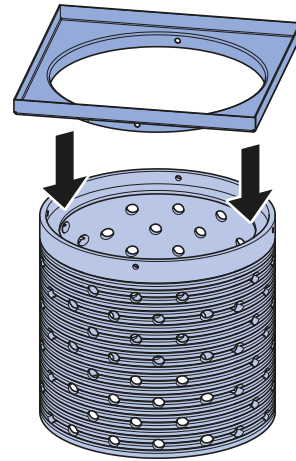

8

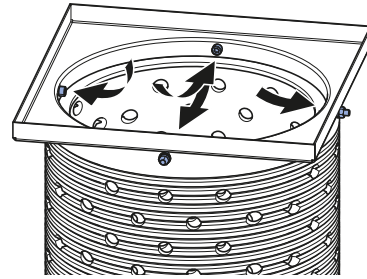
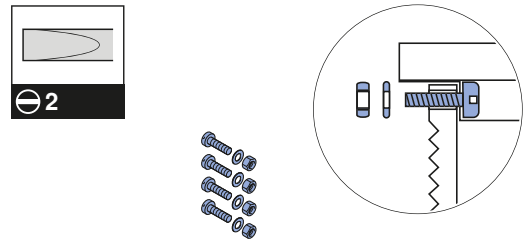

9

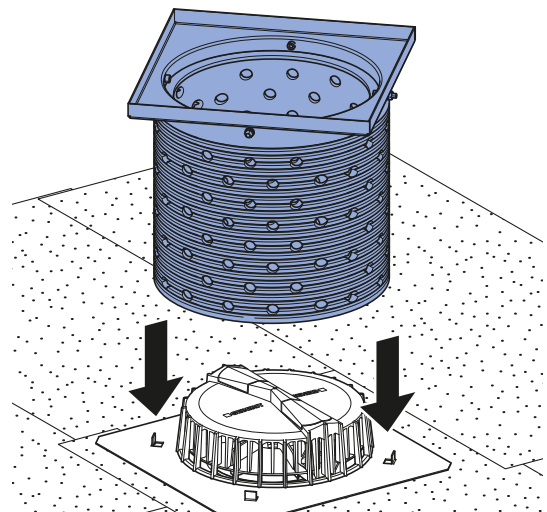

10

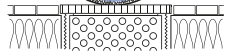
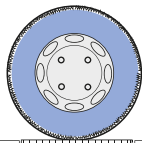
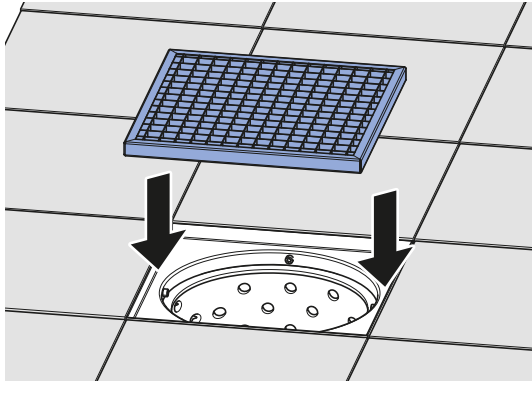

≤ 1500 kg
(Kl.: L15 – EN 1253)

Geberit International AG
Schachenstrasse 77, CH-8645 Jona
documentation@geberit.com
www.geberit.com

