

Cooker hob Milanello Gold - 7681 009

Cooker hobs

Code: 7681 009

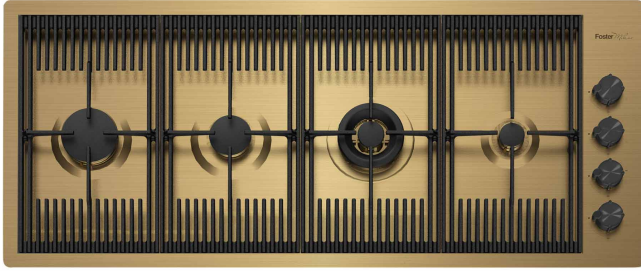

DETAILS

Coloring Gold

Finish PVD

Material AISI 304 stainless steel

Texture Satin

Supply 220-240 V; 50.60 Hz

Edge/Installation Type Flush-mount | Top-mount

Dimensions 1115x476 mm

Base size 112cm

Heating element Four burners

Built-in hole	View technical data sheet (for all Flush-mount / Top-mount models and Under-mount models)
Grids	Cast iron grids and enamelled burner covers
Total power	10.750 W
Auxiliary	1.000 W
Semirapid	1.750 W
Rapid	3.000 W
Dual	5.000 W
Safety	Safety valve with quick-acting thermocouple
Ignition	Electric ignition under knob
Gas type	Tested for installation with natural gas, LPG nozzle set included.
Type	Gas Hob

FEATURES

Gold	The Gold finish is obtained by treating the steel with a physical process called PVD (Physical Vacuum Deposition) which deposits particles of noble metals on the surface. The result is a unique and refined aesthetic effect, and an improvement in the mechanical properties of the steel that is more resistant to shocks and scratches.
Aeo burners	The AEO burners guarantee up to 25% energy saving compared to standard burners. All models are designed with The Dual burner with 2 independent crowns, controlled by a single knob, delivers from 1 to 5KW, a power that can only be found in professional models.

Cast iron grids

Cast-iron is the ideal material for an hob grid, this due to the manifold properties characterising it: high heat capacity that improves cooking performance; high weight and stability that improve safety; sturdiness that preserves the hob's original aspect over time; easy cleaning.

Safe cooking

All Foster cooker hobs are equipped with safety valves. They shut off the gas supply very quickly if the flame accidentally goes out.

Special burners

Many Foster hobs are equipped with special burners, with two or three rings of fire that greatly increase the power delivered and the heated surface. In the DUAL models the two fire crowns also have independent ignition, making these burners perfect for both intensive and delicate cooking.

Ultra-flat hob

Design meets functionality in the the ultra-flat models. Elegant grids that form a generously sized overall surface.

Under-knob ignition

The utmost freedom of movement with electronic under-knob ignition, a common feature of all models that allows a one-hand ignition of the burner.

TECHNICAL DATA



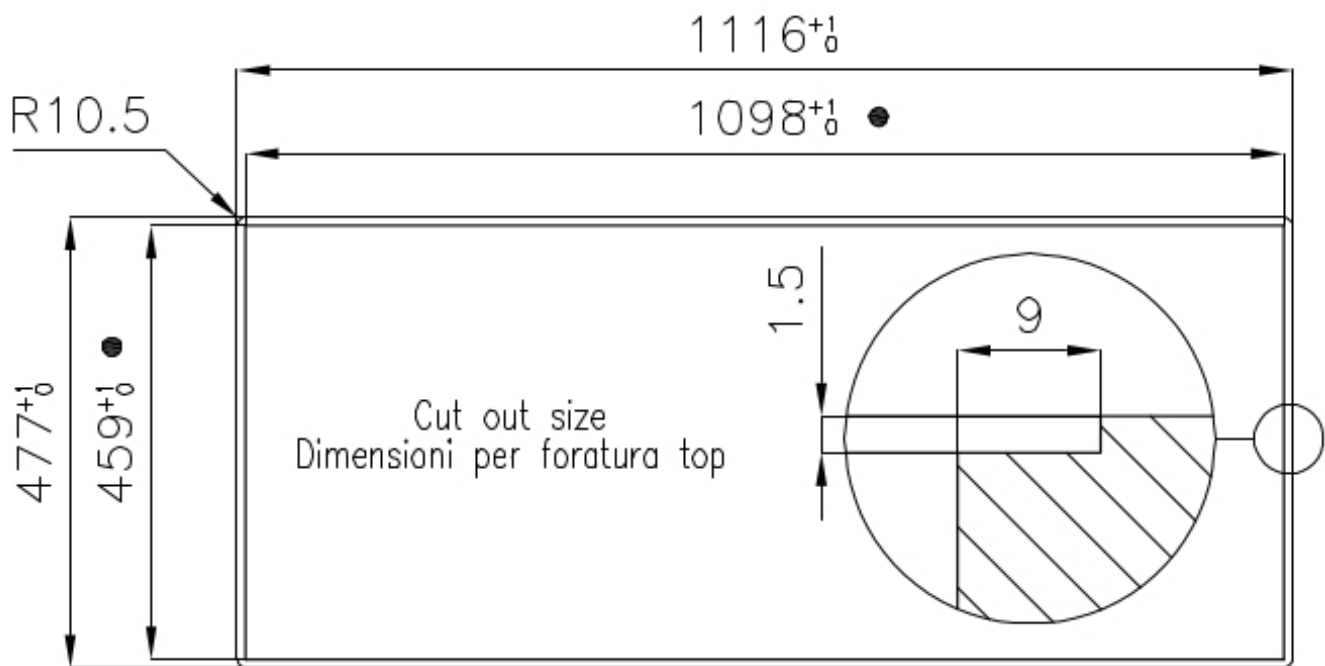

- Built-in cut out for FTS – Foratura per installazione FTS

OPTIONAL ACCESSORIES



Cast iron wok support 9601 727

RECOMMENDED PAIRINGS



Sink Milanello Gold workstation
1034 059



Sink Milanello Gold Workstation
1034 859



Sink Phantom Base Gold - 5557
149



Sink Phantom Edge Gold - 4157
019