

RICAMBI / SPARE PARTS

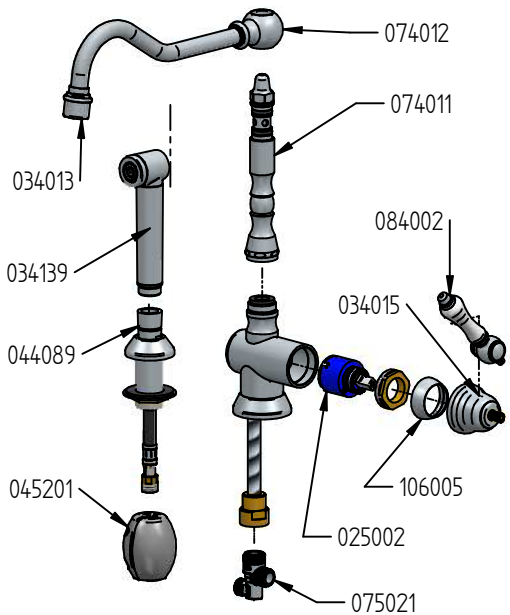

COD. 074011	COD. 034015	COD. 106005
COD. 074012	COD. 084002	COD. 025002
COD. 034139	COD. 045201	COD. 034013
COD. 044089	COD. 075021	

CUCINA

Istruzioni di installazione / Installation instruction

Art. 0850/2/L



Per installatore: Al fine di garantire la durata del prodotto installare rubinetti sottolavabo con filtro da pulire periodicamente. Effettuare risciacquo delle tubazioni prima di installare il prodotto (PUNTO 1). Eventuali residui se finissero all'interno della cartuccia potrebbero cusarne il danneggiamento.
For installer: In order to guarantee a long duration of the product install angle valves with filter, which have to be regularly cleaned (POINT 1). Carry out the rinsing of the pipes before install the tap. Some external materials may damage the cadridge if not removed before installation

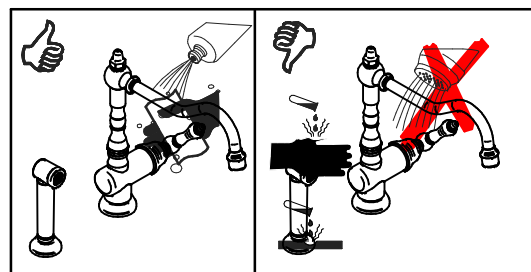

MANUTENZIONE E PULIZIA

Per una corretta manutenzione e pulizia di questo prodotto, raccomandiamo alcuni semplici accorgimenti:

- Utilizzare **detergenti neutri**, spruzzando il prodotto direttamente su un panno morbido onde evitare infiltrazioni
- Evitare **sempre** il contatto con prodotti acidi o abrasivi
- **Risciacquare bene** con abbondante acqua per eliminare eventuali residui ed **asciugare sempre** con un panno morbido
- Effettuare una **pulizia periodica** al fine di prevenire le formazioni calcaree

La BELLOSTA CARLO & C. non è RESPONSABILE di danni derivati dall'utilizzo di prodotti impropri per la pulizia.

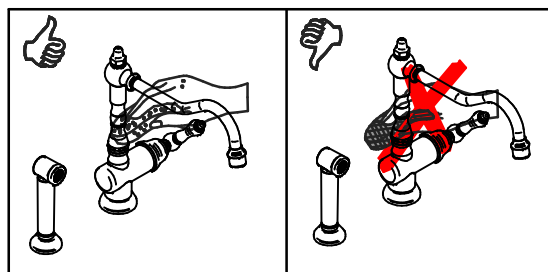

MAINTENANCE AND CLEANING

For a proper maintenance and cleaning, we recommend the following:

- Use **neutral detergents**, avoiding to spray directly on taps to avoid residual infiltration
- **Avoid** contact with acid or abrasive products
- **Rinse** with water and **always dry** with a clean cloth to avoid residue of detergent
- Perform a **periodic cleaning** to prevent limestone deposits

BELLOSTA CARLO & C. cannot be held responsible for damages due to an improper use of detergents

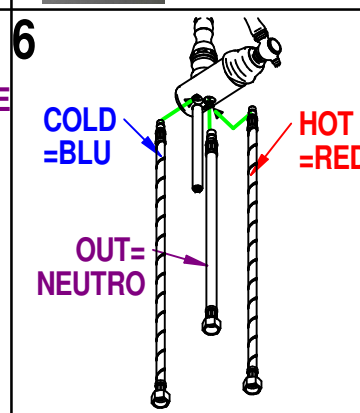
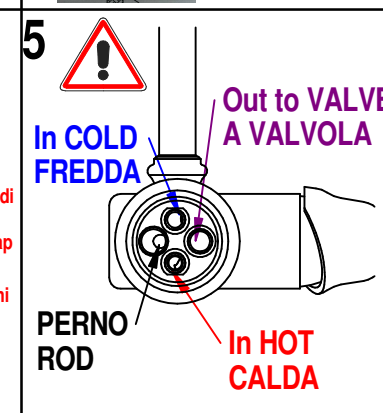
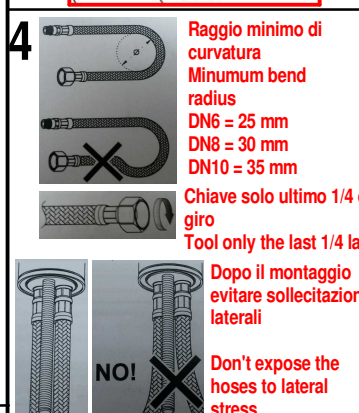
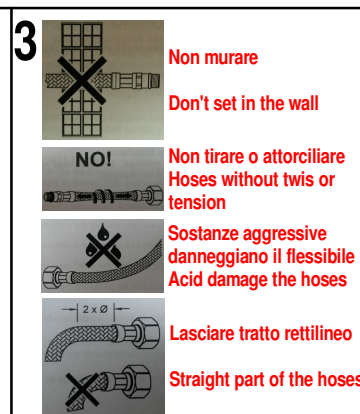
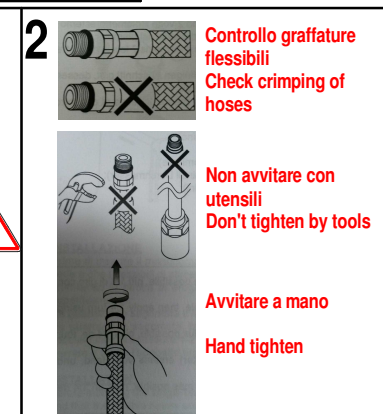

ufficio tecnico BELLOSTA
C.A. 09/17 ISO 9001:2015



MADE IN ITALY

Questo prodotto è stato realizzato interamente in Italia con l'utilizzo di materie prime di altissima qualità

DESIGN
EOB

MADE IN ITALY

This product has been entirely manufactured in Italy, by top quality raw materials.



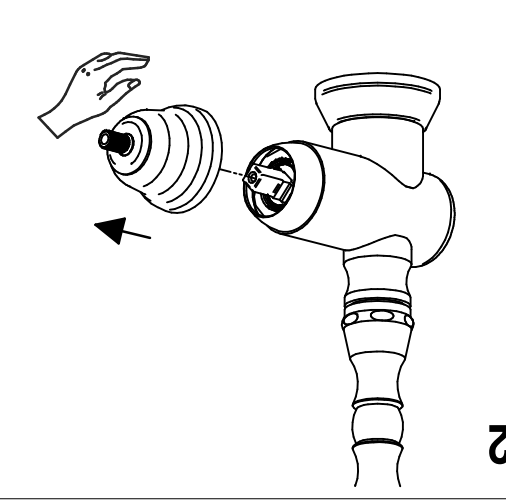
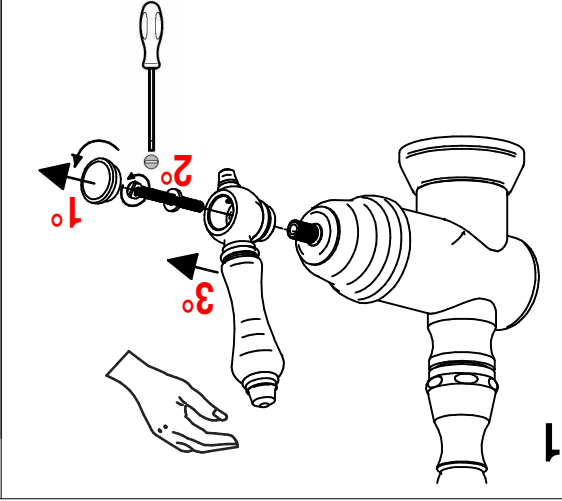
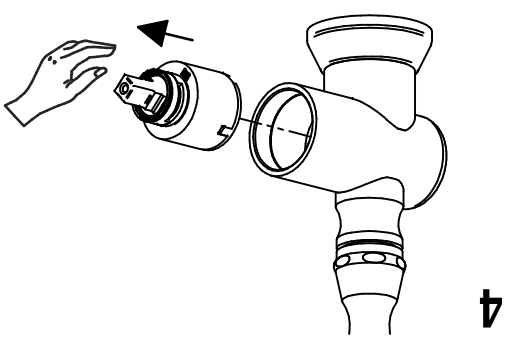
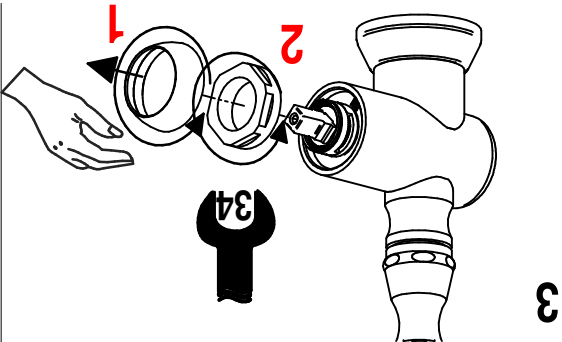
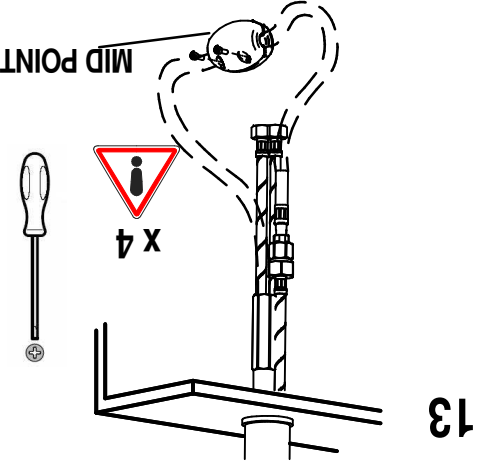
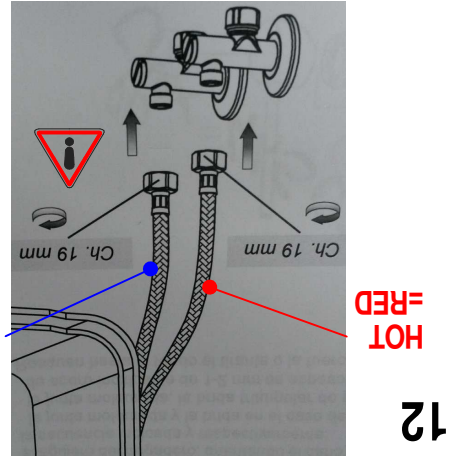
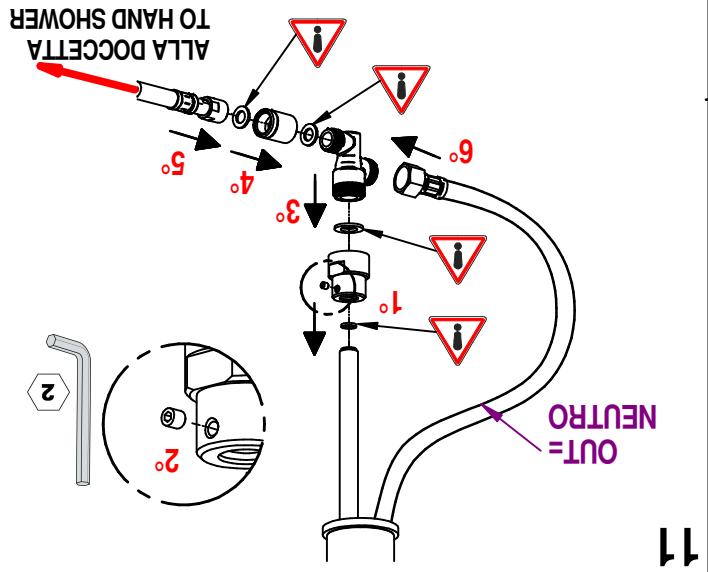
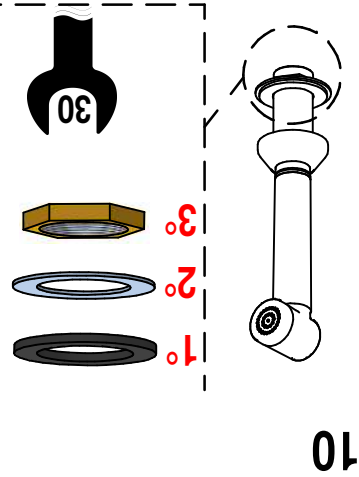
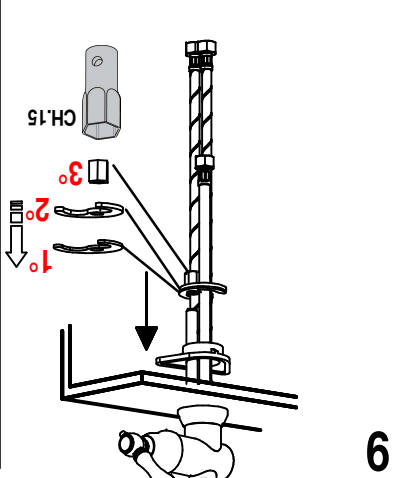
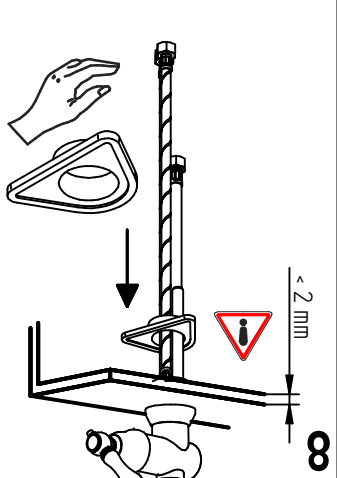
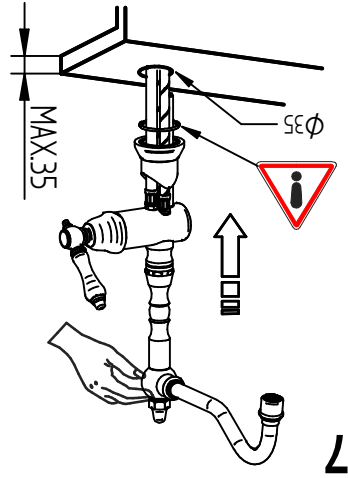

SOSTITUZIONE AERATORE / AERATOR REPLACEMENT

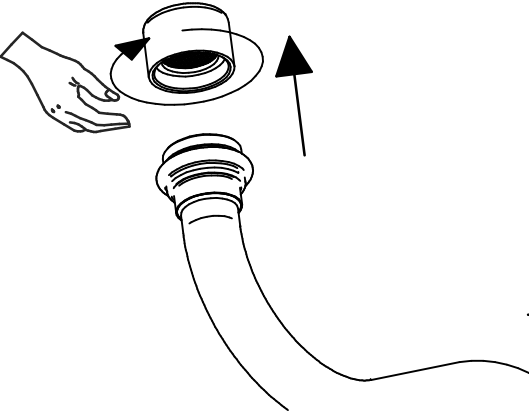

SOSTITUZIONE CARTUCCIA / CARTRIDGE REPLACEMENT

Prima di iniziare le operazioni di sostituzione della cartuccia assicurarsi che l'acqua dell'impianto principale sia chiusa e che la cartuccia sia svuotata da residui di acqua.
Before starting replacement of cartridge, ensure that water system has been turned off and empty remaining water.

Per qualsiasi richiesta di informazioni, preghiamo contattare l'Ufficio Tecnico presso: info@bellostarubINETTERIE.com

For any technical inquiries, please contact the Technical Office at: info@bellostarubINETTERIE.com