

RICAMBI / SPARE PARTS

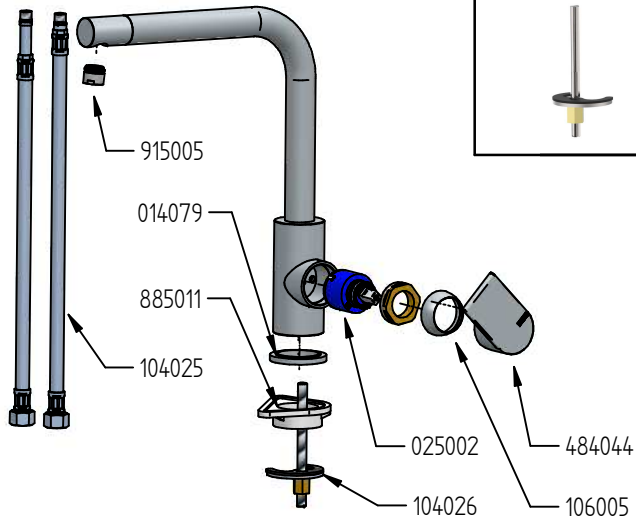

COD. 104026



COD. 484044



COD. 106005



COD. 025002



COD. 014079



COD. 885011



COD. 915005

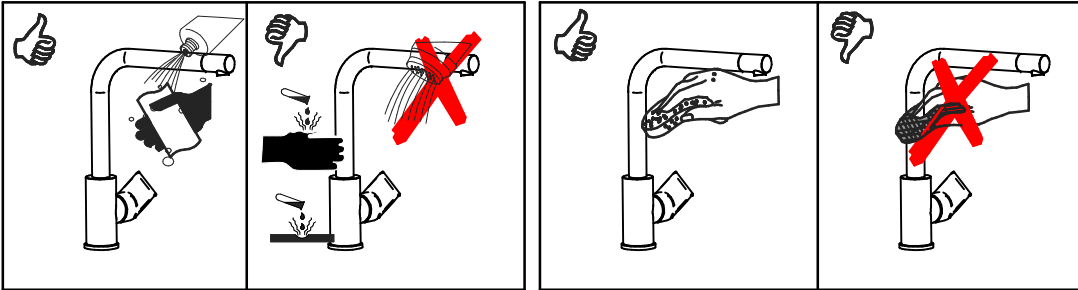

MANUTENZIONE E PULIZIA

Per una corretta manutenzione e pulizia di questo prodotto, raccomandiamo alcuni semplici accorgimenti:

- Utilizzare detersivi neutri, spruzzando il prodotto direttamente su un panno morbido onde evitare infiltrazioni
- Evitare sempre il contatto con prodotti acidi o abrasivi
- Risciacquare bene con abbondante acqua per eliminare eventuali residui ed asciugare sempre con un panno morbido
- Effettuare una pulizia periodica al fine di prevenire le formazioni calcaree

La BELLOSTA CARLO & C. non è RESPONSABILE di danni derivati dall'utilizzo di prodotti impropri per la pulizia.

MAINTENANCE AND CLEANING

For a proper maintenance and cleaning, we recommend the following:

- Use neutral detergents, avoiding to spray directly on taps to avoid residual infiltration
- Avoid contact with acid or abrasive products
- Rinse with water and always dry with a clean cloth to avoid residue of detergent
- Perform a periodic cleaning to prevent limestone deposits

BELLOSTA CARLO & C. cannot be held responsible for damages due to an improper use of detergents



9001-2015 I

socio sostenitore

associato

CUCINA

Istruzioni di installazione / Installation instruction

ART. 4810/1



Per installatore: Al fine di garantire la durata del prodotto installare rubinetti sottolavabo con filtro da pulire periodicamente. Effettuare risciacquo delle tubazioni prima di installare il prodotto (PUNTO 1). Eventuali residui se finissero all'interno della cartuccia potrebbero causare il danneggiamento. **For installer:** In order to guarantee a long duration of the product install angle valves with filter, which have to be regularly cleaned (POINT 1). Carry out the rinsing of the pipes before install the tap. Some external materials may damage the cadridge if not removed before installation

1
IMPORTANTISSIMO

2

3

4

5

6

Controllare graffiature flessibili
Check crimping of hoses

Non avvitare con utensili
Don't tighten by tools

Avvitare a mano
Hand tighten

Non murare
Don't set in the wall

NO!
Non tirare o attorcigliare Hoses without twis or tension

Sostanze aggressive danneggiano il flessibile
Acid damage the hoses

Lasciare tratto rettilineo
Straight part of the hoses

Raggio minimo di curvatura
Minum bend radius
DN6 = 25 mm
DN8 = 30 mm
DN10 = 35 mm

Chiave solo ultimo 1/4 di giro
Tool only the last 1/4 lap

Dopo il montaggio evitare sollecitazioni laterali
Don't expose the hoses to lateral stress

MAX. 45

ufficio tecnico BELLOSTA
S.F. 11/16 ISO 9001:2015

MADE IN ITALY

Questo prodotto è stato realizzato interamente in Italia con l'utilizzo di materie prime di altissima qualità

DESIGN
EOB

MADE IN ITALY

This product has been entirely manufactured in Italy, by top quality raw materials.



Rubinetti d'autore dedicati a te

SOSTITUZIONE CARTUCCIA / CARTRIDGE REPLACEMENT



Prima di iniziare le operazioni di sostituzione della cartuccia assicurarsi che l'acqua dell'impianto principale sia chiusa e che la cartuccia sia svuotata da residui di acqua.
Before starting replacement of cartridge, ensure that water system has been turned off and empty remaining water.

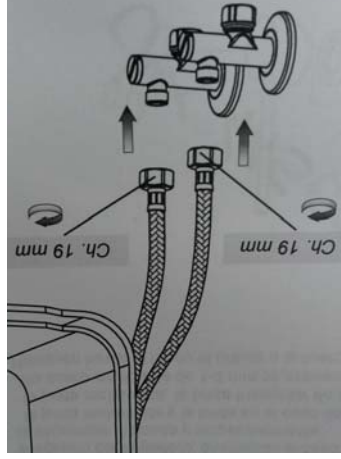
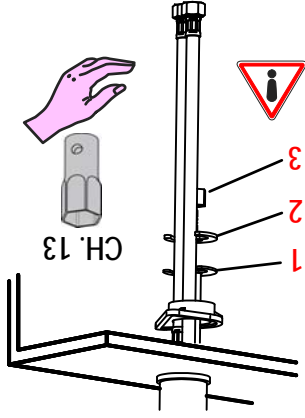
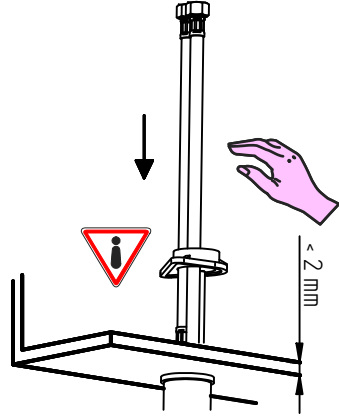
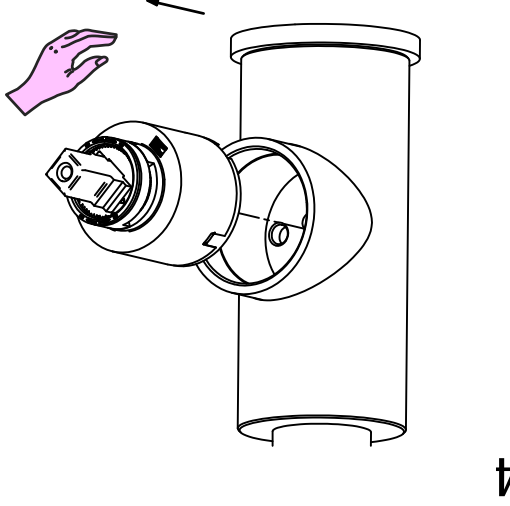
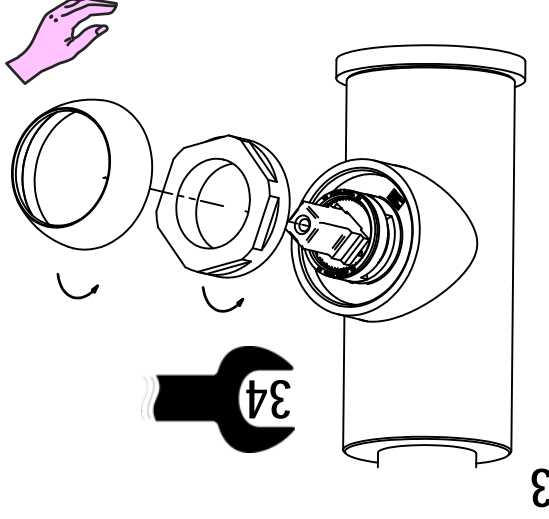
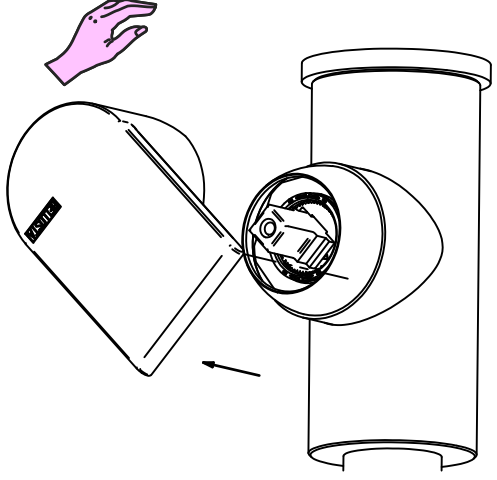
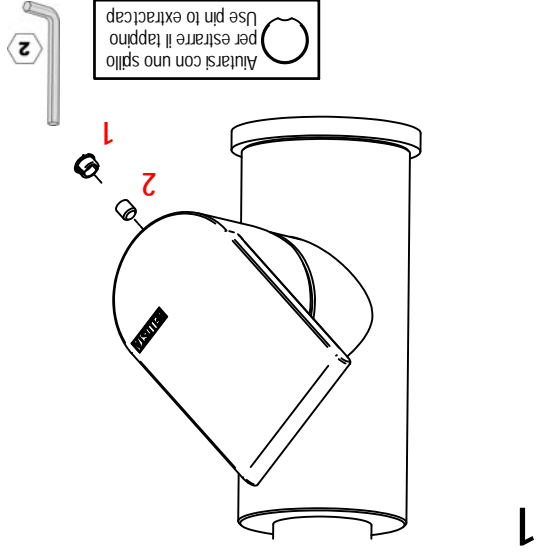

SOSTITUZIONE AERATORE / AERATOR REPLACEMENT

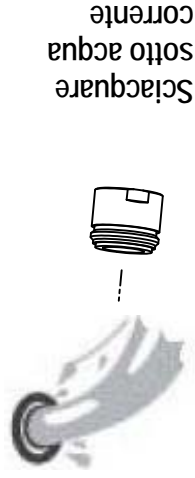
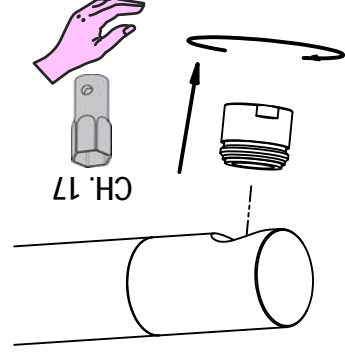

Sopra i 3 Bar è necessario l'uso di un regolatore di pressione
Above 3 Bar a pressure regulator must be installed

Per qualsiasi richiesta di informazioni, preghiamo contattare l'Ufficio Tecnico presso:
info@bellostarubinetterie.com

For any technical inquiries, please contact the Technical Office at: info@bellostarubinetterie.com