



KNIGHT™ LITTER RECEPTACLE

PRODUCT DATA





KNIGHT™ LITTER RECEPTACLE

PRODUCT DATA

The **Knight Litter Receptacle** combines rustproof construction, high-performance materials, and the striking aesthetic of the rest of the Knight family. The finned quadrant frame is seamless aluminum with beautifully detailed polished edges. The removable cast aluminum lid provides easy access and comes with tether cables for added security. Distinctive and highly durable, the Knight Litter Receptacle is the perfect accompaniment to other Knight family members: backed and backless benches, a table ensemble, illuminated and security bollards, and pedestrian lighting.

MATERIAL & CONSTRUCTION DETAILS

INSTALLATION & MAINTENANCE

FRAME & LID	BODY	LINER	INSTALLATION	MAINTENANCE
<ul style="list-style-type: none"> • Quadrant frame and angled lid are made of corrosion-resistant solid aluminum with invisible welds. • Quadrant frame, lid, and inner surfaces are Aluminum Texture powdercoat with polished outer edges. All surfaces are clear-coated. 	<ul style="list-style-type: none"> • Knight's body is made of corrosion-resistant aluminum. • See the Forms+Surfaces Powdercoat Chart for details. Custom RAL colors are available for an upcharge. 	<ul style="list-style-type: none"> • The Knight receptacle uses independent, replaceable internal liners designed to be used with or without plastic litter bags. • Liners are molded from durable black polyethylene with a UL94HB fire rating. 	<ul style="list-style-type: none"> • Receptacles can be used freestanding or surface mounted. • Anchors, levelers, and stainless steel mounting screws are provided when surface mounting is specified; levelers are supplied for freestanding units. • For added security, lids are supplied with two stainless steel tether chains. 	<ul style="list-style-type: none"> • Metal surfaces can be cleaned as needed using a soft cloth or brush with warm water and a mild detergent. Avoid abrasive cleaners.

NOMINAL DIMENSIONS

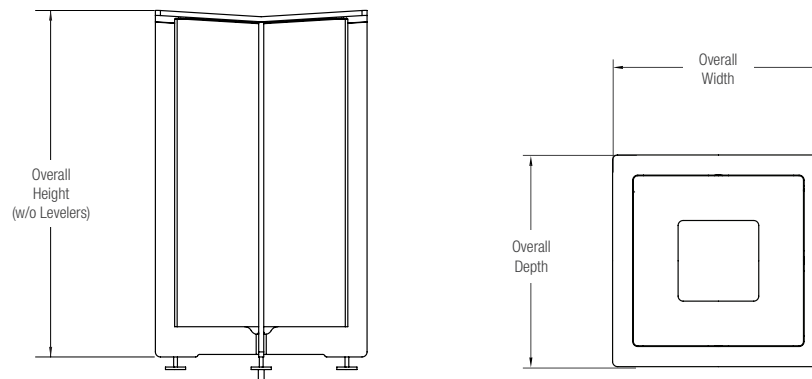

MODEL	OVERALL HEIGHT	OVERALL WIDTH	OVERALL DEPTH	OVERALL WEIGHT	CAPACITY
SLKNI-30	34.4" (874 mm)	21.0" (533 mm)	21.0" (533 mm)	63.4 lbs (28.8 kg)	30 gallons (114 liters)

ENVIRONMENTAL CONSIDERATIONS

- Please refer to the Knight Receptacle Environmental Data Sheet for detailed environmental impact information.
- Knight Receptacles have up to 42% recycled content; All components are fully recyclable.
- Rustproof aluminum construction ensures a long product life cycle.
- Standard powdercoat finishes are no-VOC; non-standard powdercoat finishes are no- or low-VOC, depending on color.
- Low maintenance.



KNIGHT™ LITTER RECEPTACLE

PRODUCT DATA

MODEL NUMBER AND DESCRIPTION

MODEL	DESCRIPTION
SLKNI-30	Knight Litter Receptacle, 30-gallon

PRODUCT OPTIONS

The following options are available for an upcharge

Premium Texture Colors from Forms+Surfaces Powdercoat Chart
Custom RAL powdercoat color

LEAD TIME: 6 to 8 weeks. Shorter lead times may be available upon request. Please contact us to discuss your specific timing requirements.

PRICING: Please contact us at **800.451.0410** or **sales@forms-surfaces.com**. At Forms+Surfaces, we design, manufacture and sell our products directly to you. Our sales team is available to assist you with questions about our products, requests for quotes, and orders. Territory Managers are located worldwide to assist with the front-end specification and quoting process, and our in-house Project Sales Coordinators follow your project through from the time you place an order to shipment.

TO ORDER SPECIFY: Quantity, model, powdercoat colors, liner with or without drain holes, freestanding or surface mount. Quote/Order Forms are available on our website to lead you through the specification process in a simple checkbox format.