



ORBIT™ LITTER & RECYCLING RECEPTACLE

PRODUCT DATA





ORBIT™ LITTER & RECYCLING RECEPTACLE

PRODUCT DATA

Orbit Litter & Recycling Receptacles provide a wide array of design options, making them a unique solution suitable for indoors or out. Orbit is available with a stainless steel or Fused Metal® body. Fused Metal adds a touch of color, while boasting the same durable characteristics of stainless steel. Both single-stream and split-stream models use hinged cast aluminum lids, with graphics clearly identifying the function of each opening. This sturdy, one-of-a-kind receptacle is an efficient, eye-catching answer wherever litter and recycling solutions are needed.

MATERIAL & CONSTRUCTION DETAILS

INSTALLATION & MAINTENANCE

BODY MATERIALS & FINISHES	FRAME	LID & GRAPHICS	INSTALLATION
<ul style="list-style-type: none"> The body's two main panels and two accent panels are made of stainless steel, Fused Bronze, or Fused Nickel Silver. Stainless steel bodies are available with Sandstone, Seastone, Linen, Diamond, and Satin finishes. Fused Bronze and Fused Nickel Silver bodies are available with Sandstone, Seastone, and Diamond finishes. 	<ul style="list-style-type: none"> Top and bottom rings are made of corrosion-resistant solid cast aluminum with powdercoat finish. Vertical frame supports are made of stainless steel. See the Forms+Surfaces Powdercoat Chart for details. Custom RAL colors are available for an upcharge. Due to the inherent nature of metal castings, gloss powdercoats are not offered for cast components. 	<ul style="list-style-type: none"> The top-opening, hinged lid is made of corrosion-resistant solid-cast aluminum with powdercoat finish. See the Forms+Surfaces Powdercoat Chart for details. Custom RAL colors are available for an upcharge. Due to the inherent nature of metal castings, gloss powdercoats are not offered for cast components. Both single-stream and split-stream lids include instructional graphics with black, blue, or green backgrounds and white messages and symbols, clearly indicating the use for each opening. Graphics are printed on the back of clear, lightly textured polycarbonate, protecting them from wear over time. 	<ul style="list-style-type: none"> Orbit may be used freestanding or surface mounted. Anchors, levelers, and stainless steel mounting screws are provided when surface mounting is specified; levelers are supplied for freestanding units.
BODY PANELS & PATTERNS	BASE	LINERS	MAINTENANCE
<ul style="list-style-type: none"> Main panels cover the wide sides of the receptacle; patterns are not applicable. Accent panels cover the narrow sides of the receptacle and are available with the following patterns: <ul style="list-style-type: none"> Eco-Etch® patterns: CrissCross™ or Seagrass (not applicable on Sandstone, Linen, or Diamond finishes). Perforation patterns: Ladder™ or Scape. 	<ul style="list-style-type: none"> The base is made of heavy black recycled rubber. Slight variation in color can occur due to the material's recycled nature. The base has a UL94HB fire rating. 	<ul style="list-style-type: none"> Orbit uses replaceable internal liners designed to be used with or without plastic litter bags. Liners can be specified with tensioned rubber bag straps and drain holes. Liners are molded from durable black polyethylene with a UL94HB fire rating. 	<ul style="list-style-type: none"> Metal surfaces can be cleaned as needed using a soft cloth or brush with warm water and a mild detergent. Avoid abrasive cleaners.

NOMINAL DIMENSIONS

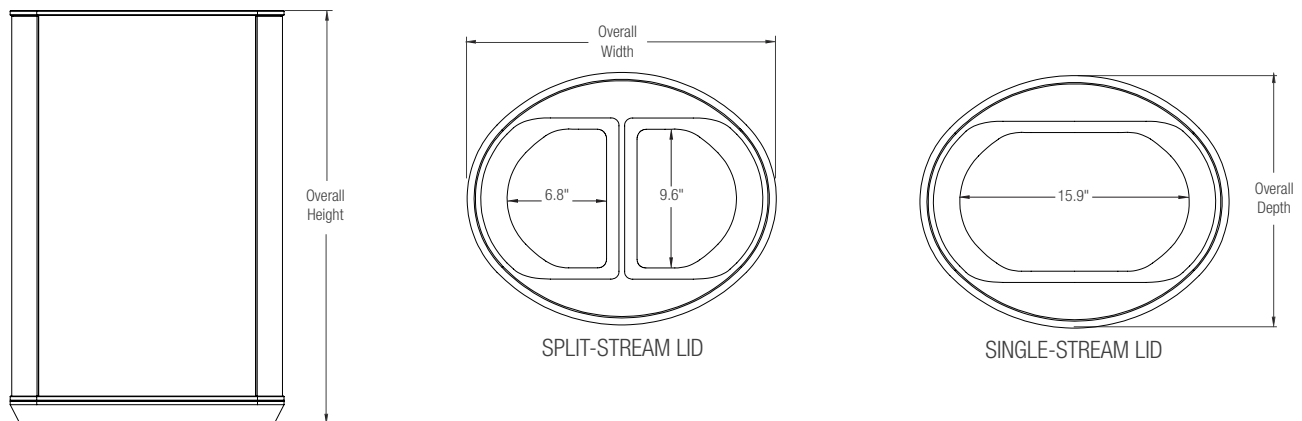

MODEL	OVERALL HEIGHT	OVERALL WIDTH	OVERALL DEPTH	OVERALL WEIGHT	CAPACITY
SLORB-130	32.1" (815 mm)	21.6" (549 mm)	17.6" (447 mm)	77 lbs (35 kg)	30 gallons (114 liters)
SLORB-213	32.1" (815 mm)	21.6" (549 mm)	17.6" (447 mm)	77 lbs (35 kg)	26 (2x13) gallons (98 liters)

T 800.451.0410 | www.forms-surfaces.com

FORMS+SURFACES®

© 2017 Forms+Surfaces® | All dimensions are nominal. Specifications and pricing subject to change without notice. For the most current version of this document, please refer to our website at www.forms-surfaces.com.



ORBIT™ LITTER & RECYCLING RECEPTACLE

PRODUCT DATA

STAINLESS STEEL BODY FINISH OPTIONS

Stainless steel is available in a variety of distinctive finishes, including standard and High-Durability options. High-Durability finishes—designated by the “HD” logo below—are manufactured in a process that creates a work-hardened surface with enhanced resistance to abrasion and wear.



FUSED METAL BODY FINISH OPTIONS

Sandstone, Seastone, and Diamond are High-Durability finishes, designated by the “HD” logo below—are manufactured in a process that create a work-hardened surface with enhanced resistance to abrasion and wear.



STANDARD GRAPHICS

Instructional graphics for Orbit lids are available with a variety of messages and colors. All graphics are available with black backgrounds. Recycling, bottles & cans, paper, and compost graphics are also available with blue or green backgrounds to clearly indicate recycling streams. All letters and symbols are white.

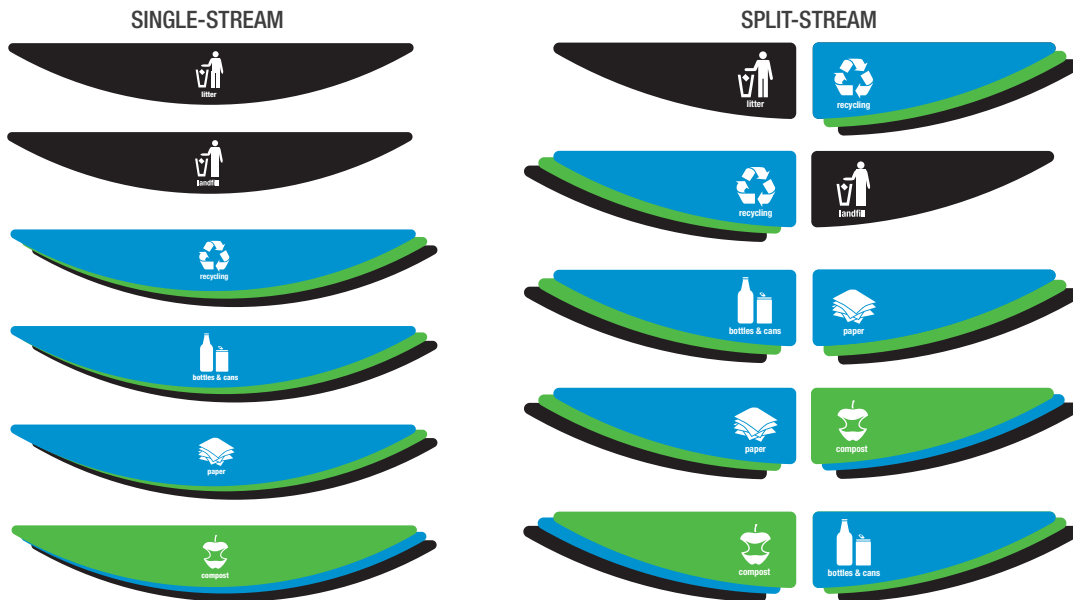



ACCENT PANEL PATTERN OPTIONS

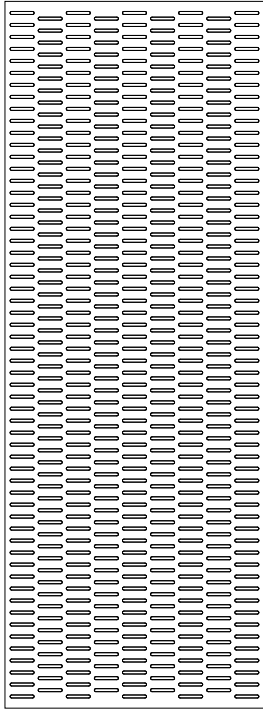

LADDER PERFORATION

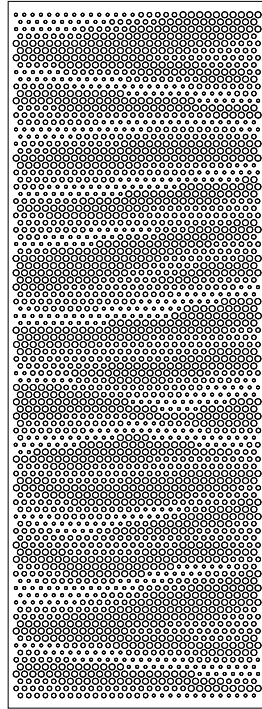

SCAPE PERFORATION



CRISSCROSS ECO-ETCH

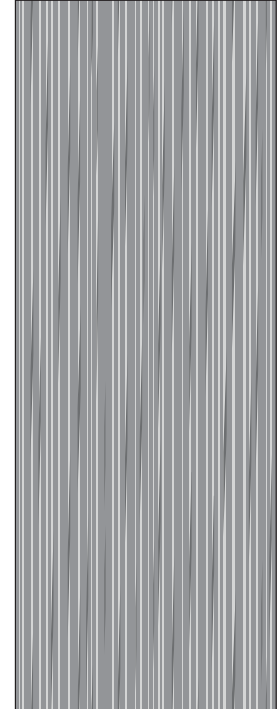

SEAGRASS ECO-ETCH

ENVIRONMENTAL CONSIDERATIONS

- Please refer to the Orbit Litter & Recycling Receptacle Environmental Data Sheet for detailed environmental impact information.
- Orbit has a high recycled content.
- All components are fully recyclable.
- Powdercoat finishes are no- or low-VOC, depending on color.
- Low maintenance.

MODEL NUMBERS AND DESCRIPTIONS

MODEL	DESCRIPTION
SLORB-130S	Orbit Receptacle, Stainless Steel, single-stream, (1) 30-gallon liner
SLORB-213S	Orbit Receptacle, Stainless Steel, split-stream, (2) 13-gallon liners
SLORB-130F	Orbit Receptacle, Fused Metal, single-stream, (1) 30-gallon liner
SLORB-213F	Orbit Receptacle, Fused Metal, split-stream, (2) 13-gallon liners



ORBIT™ LITTER & RECYCLING RECEPTACLE

PRODUCT DATA

PRODUCT OPTIONS

The following options are available for an upcharge

Add standard perforation or Eco-Etch pattern to accent panels

LEAD TIME: 6 to 8 weeks. Shorter lead times may be available upon request. Please contact us to discuss your specific timing requirements.

PRICING: Please contact us at **800.451.0410** or **sales@forms-surfaces.com**. At Forms+Surfaces, we design, manufacture and sell our products directly to you. Our sales team is available to assist you with questions about our products, requests for quotes, and orders. Territory Managers are located worldwide to assist with the front-end specification and quoting process, and our in-house Project Sales Coordinators follow your project through from the time you place an order to shipment.

TO ORDER SPECIFY: Quantity, model, main panel, accent panel, lid graphics, freestanding or surface mount. Quote/Order Forms are available on our website to lead you through the specification process in a simple checkbox format.

NOTE: Because different computers will render colors and textures differently, actual colors and finishes may vary from those shown here.