



TONYO™ LITTER & RECYCLING RECEPTACLE

PRODUCT DATA





TONYO™ LITTER & RECYCLING RECEPTACLE

PRODUCT DATA

Tonyo Litter & Recycling Receptacles offer a beautifully modern solution for a wide range of settings and waste collection needs. Defined by streamlined aesthetics and robust, low-maintenance materials, Tonyo's highly adaptable framework acts as a canvas for endless customization. Receptacles are available in 30-, 36- and 60-gallon capacities, each with configurable options that include single- and split-stream variations, bodies and doors in powdercoated stainless steel or FSC® 100% Cumaru hardwood slats, rain hats, and instructional waste stream graphics. Opportunities for color-blocking and incorporating custom branding and graphics expand the line's visual and messaging potential and contribute to its far-reaching, design-forward appeal.

MATERIAL & CONSTRUCTION DETAILS

INSTALLATION & MAINTENANCE

CONFIGURATION OPTIONS & LINERS	BODY & DOOR MATERIAL OPTIONS	INSTALLATION
<ul style="list-style-type: none"> Tonyo Receptacles are available in 30-, 36-, and 60-gallon capacities. 30- and 36-gallon models are available in single- or split-stream configurations; 60-gallon models are available as split-stream only. Single-stream receptacles use a single 30- or 36-gallon liner. Split-stream receptacles use two 15-, 18-, or 30-gallon liners. Liners are black polyethylene with integral bag straps and hand holes. 	<ul style="list-style-type: none"> Receptacle lid, sidebars, and base are corrosion-resistant cast and extruded aluminum with a powdercoat finish. Internal frame is stainless steel. Body and doors are available in either powdercoated stainless steel or FSC® 100% Cumaru hardwood slats with corrosion-resistant cast aluminum supports. (FSC License Code: FSC-C004453) Stainless steel body and doors can be specified in a powdercoat color that matches or contrasts with the rainhat, sidebars, base, and/or lid. Powdercoat options vary per receptacle configuration; refer to page 6 for more information. See the Forms+Surfaces Powdercoat Chart for details. Custom RAL colors are available for an upcharge. 	<ul style="list-style-type: none"> 30-gallon Tonyo Receptacles are mounted on a pole and can either be cast-in-place or surface-mounted. 36- and 60-gallon Tonyo Receptacles are available as freestanding with levelers or surface-mounted with levelers. Anchors and stainless steel mounting screws are provided when surface mounting is specified; levelers are supplied for freestanding and surface-mount receptacles.
<p>SIDE ACCESS DOOR AND LATCH</p> <ul style="list-style-type: none"> Hinged side-access doors open in a clamshell fashion. 30- and 36-gallon models have a single door on the left side; 60-gallon models have a door on either side of the receptacle. Latches and hinges are stainless steel. Standard latch option is a lift latch; a limited-access latch operated with a flathead screwdriver is also available. 		
<p>RAIN HATS</p> <ul style="list-style-type: none"> 30-gallon receptacles are standard with rain hats. 36- and 60-gallon are available with or without rain hats. Rain hats are corrosion-resistant cast aluminum with a powdercoat finish. See the Forms+Surfaces Powdercoat Chart for details. Custom RAL colors are available for an upcharge. 	<p>GRAPHICS</p> <ul style="list-style-type: none"> Instructional graphics are optional and are available with a variety of standard messages that clearly indicate the use for each opening. Graphics have white letters and symbols with black, blue, or green backgrounds. Graphics are printed on the back of clear, lightly textured polycarbonate, protecting them from wear over time. Reference pages 7-9 for graphic options and placement. 	<p>MAINTENANCE</p> <ul style="list-style-type: none"> Polyethylene and metal surfaces can be cleaned as needed using a softcloth or brush with warm water and a mild detergent. Avoid abrasive cleaners. Cumaru hardwood can be maintained by re-oiling as needed with Penofin® hardwood finish or similar products.

CREATIVE CANVAS

Tonyo's impressive customization potential is the result of multiple configurable elements that make up each finished design, as described above. As outlined on the following pages, specifics vary per receptacle size and configuration and generally encompass several key arenas:

Materials & Colors: Receptacle bodies and doors can be specified in powdercoated stainless steel or with slats of FSC 100% Cumaru hardwood. Receptacle lids, sidebars, bases, and rain hats are available in the same palette of powdercoat colors and can be specified to match or contrast with receptacle body and door materials to create a monochromatic look or achieve unique color-blocking effects.

Waste Stream Graphics: Designed to be both elegant and informational, optional waste stream graphics accommodate multiple waste streams. Keeping with Tonyo's clean aesthetics, placement is optimized per receptacle size, material combination, and configuration.

Custom Graphics: Powdercoated stainless steel bodies and doors can be customized with branding and graphics—an especially fitting choice for municipalities, universities, and other sites seeking property-aligned personalization. Options include laser-cut designs with stainless steel backers, and/or vinyl graphics.



TONYO™ LITTER & RECYCLING RECEPTACLE

PRODUCT DATA

30-GALLON NOMINAL DIMENSIONS

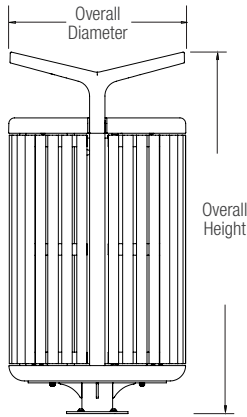

FSC 100% Cumaru hardwood body/door, surface-mounted

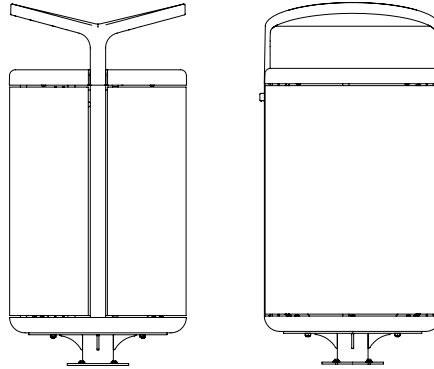

Stainless steel body/door, surface-mounted

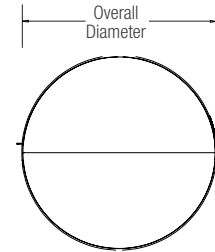

Top view
(See 36-gallon drawings for waste stream opening dimensions)

MODEL	OVERALL DIAMETER	OVERALL HEIGHT*	OVERALL WEIGHT	CAPACITY / LINERS
SLTNO-130C	23.1" (587 mm)	47.1" (1196 mm)	148 lbs (67.1 kg)	(1) 30-gallon liner
SLTNO-130S	23.1" (587 mm)	47.1" (1196 mm)	151 lbs (68.5 kg)	(1) 30-gallon liner
SLTNO-215C	23.1" (587 mm)	47.1" (1196 mm)	152 lbs (69 kg)	(2) 15-gallon liners
SLTNO-215S	23.1" (587 mm)	47.1" (1196 mm)	156 lbs (70.8 kg)	(2) 15-gallon liners

*Cast-in-place models have 24" of additional in-ground pole length, and 15 lbs additional weight.



TONYO™ LITTER & RECYCLING RECEPTACLE

PRODUCT DATA

36-GALLON NOMINAL DIMENSIONS

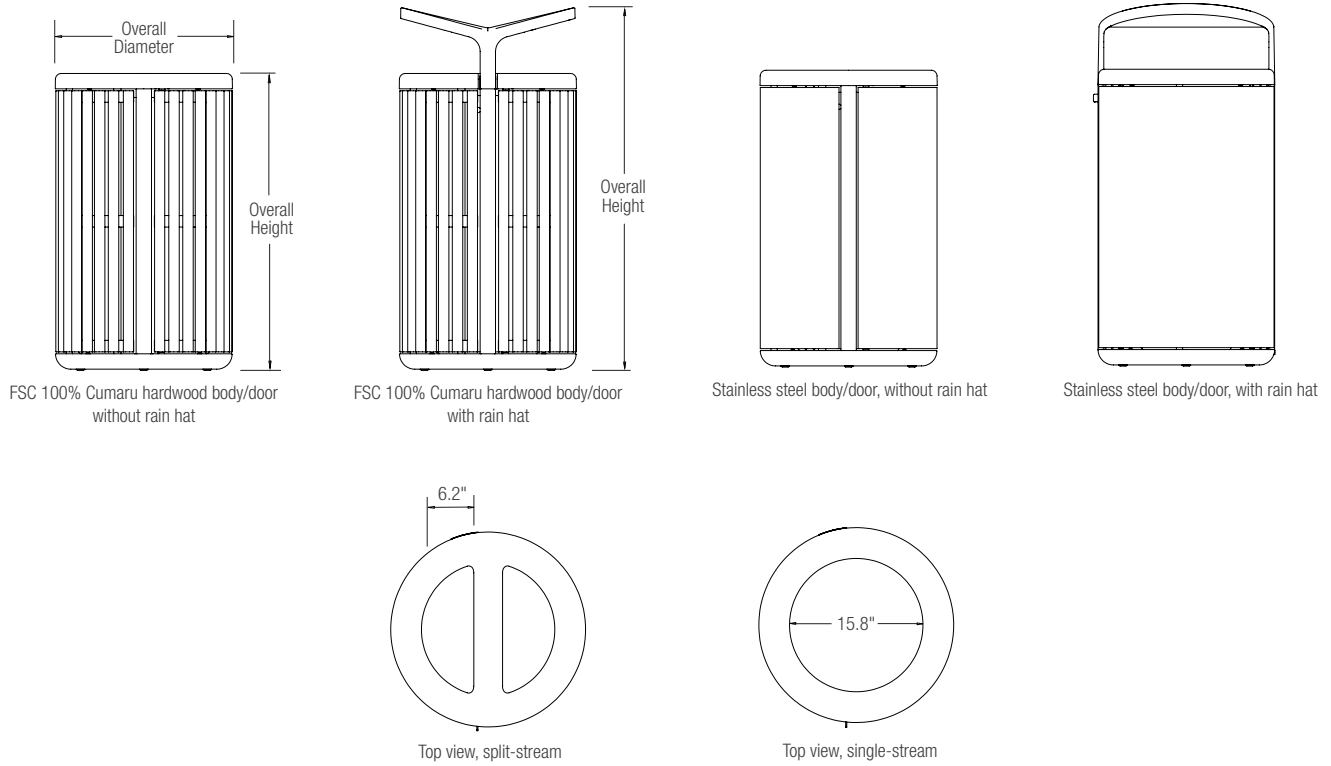

MODEL	OVERALL DIAMETER	OVERALL HEIGHT		OVERALL WEIGHT		CAPACITY / LINERS
		WITHOUT RAIN HAT	WITH RAIN HAT	WITHOUT RAIN HAT	WITH RAIN HAT	
SLTNO-136C	23.1" (587 mm)	38.5" (978 mm)	47.1" (1196 mm)	111 lbs (50.4 kg)	128 lbs (58.1 kg)	(1) 36-gallon liner
SLTNO-136S	23.1" (587 mm)	38.5" (978 mm)	47.1" (1196 mm)	117 lbs (53.1 kg)	134 lbs (60.8 kg)	(1) 36-gallon liner
SLTNO-218C	23.1" (587 mm)	38.5" (978 mm)	47.1" (1196 mm)	118 lbs (53.5 kg)	135 lbs (61.2 kg)	(2) 18-gallon liners
SLTNO-218S	23.1" (587 mm)	38.5" (978 mm)	47.1" (1196 mm)	125 lbs (56.7 kg)	141 lbs (64 kg)	(2) 18-gallon liners



TONYO™ LITTER & RECYCLING RECEPTACLE

PRODUCT DATA

60-GALLON NOMINAL DIMENSIONS

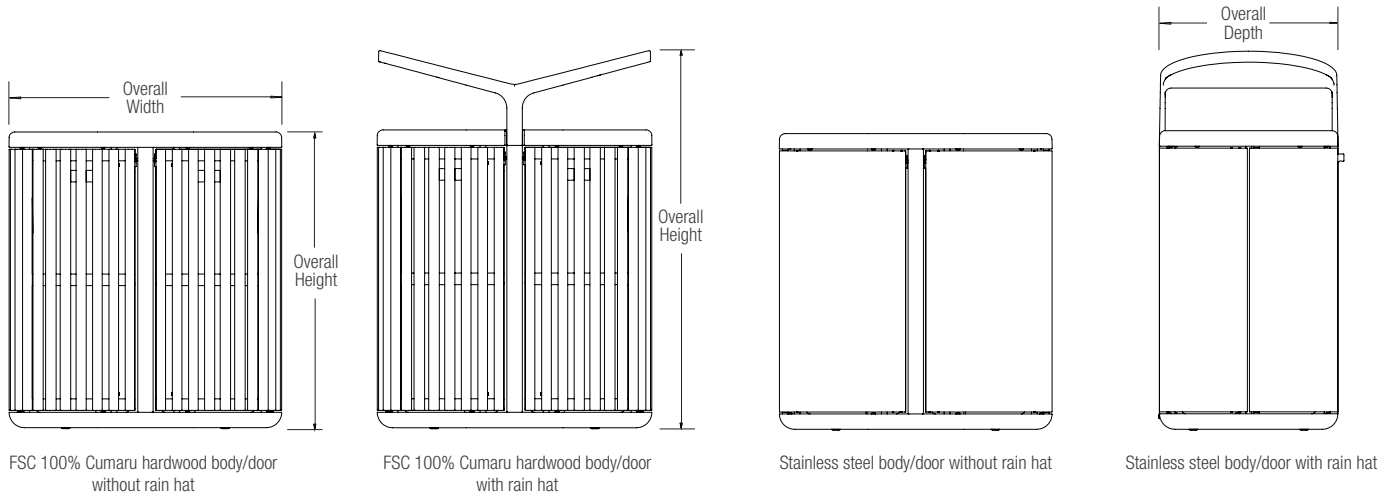

FSC 100% Cumaru hardwood body/door without rain hat

FSC 100% Cumaru hardwood body/door with rain hat

Stainless steel body/door without rain hat

Stainless steel body/door with rain hat

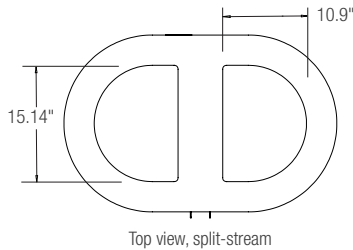

Top view, split-stream

MODEL	OVERALL WIDTH	OVERALL DEPTH	OVERALL HEIGHT		OVERALL WEIGHT		CAPACITY / LINERS
			WITHOUT RAIN HAT	WITH RAIN HAT	WITHOUT RAIN HAT	WITH RAIN HAT	
SLTNO-230C	36.5" (927 mm)	23.1" (587 mm)	38.5" (978 mm)	47.1" (1196 mm)	177 lbs (81.3 kg)	200 lbs (90.7 kg)	(2) 30-gallon liners
SLTNO-230S	36.5" (927 mm)	23.1" (587 mm)	38.5" (978 mm)	47.1" (1196 mm)	161 lbs (73 kg)	185 lbs (83.9 kg)	(2) 30-gallon liners



TONYO™ LITTER & RECYCLING RECEPTACLE

PRODUCT DATA

POWDERCOAT & COLOR-BLOCKING OPTIONS

Powdercoat options vary per configuration. Metal components on receptacles with FSC 100% Cumaru slats are standard as one color. Receptacles with stainless steel body and doors provide the option to choose one single color, or two contrasting colors for a color-blocking effect. See below for visual representation, as shown using the 36-gallon configurations.

**TONYO RECEPTACLE, 36-GALLON,
FSC 100% CUMARU HARDWOOD BODY/DOOR, WITH RAIN HAT**

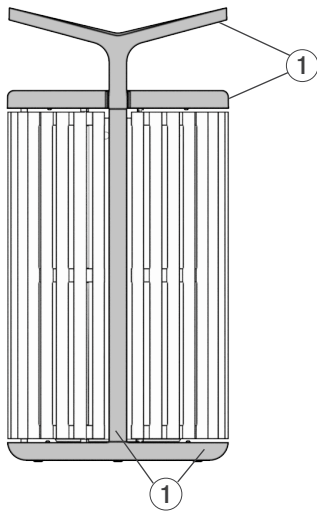

**TONYO RECEPTACLE, 36-GALLON,
STAINLESS STEEL BODY/DOOR, WITH RAIN HAT**

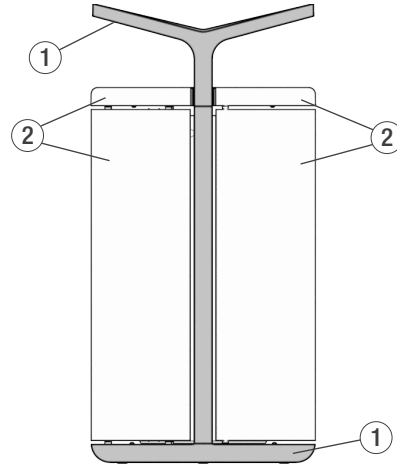

**TONYO RECEPTACLE, 36-GALLON,
FSC 100% CUMARU HARDWOOD BODY/DOOR, WITHOUT RAIN HAT**

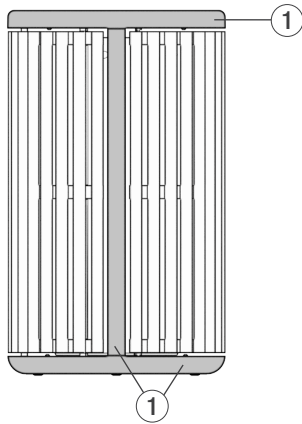

**TONYO RECEPTACLE, 36-GALLON,
STAINLESS STEEL BODY/DOOR, WITHOUT RAIN HAT**

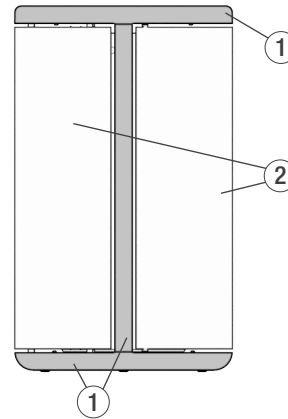



TONYO™ LITTER & RECYCLING RECEPTACLE

PRODUCT DATA

STANDARD GRAPHICS

Tonyo Receptacles can be specified with or without instructional graphics. Options vary per receptacle configuration and generally consist of multiple graphic elements that incorporate color, waste stream symbols and/or text that indicate the use for each opening. Standard background color options are Green, Blue and Black. All lettering and symbols are White.

GRAPHIC SYMBOL/MESSAGE OPTIONS



30- & 36-GALLON SINGLE-STREAM RECEPTACLE GRAPHICS (shown on 36-gallon receptacles)

Single-stream FSC 100% Cumaru configurations include a solid-colored top-of-lid graphic (A) and four horizontal door/body graphics (B) with choice of standard symbol.

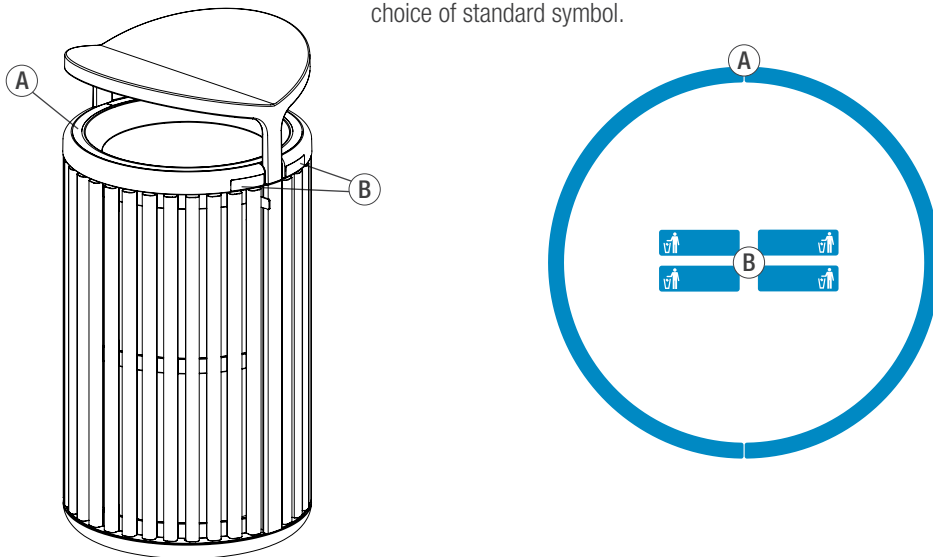

Single-stream stainless steel body/door configurations include a solid-colored top-of-lid graphic (A) and four vertical door/body graphics (B) with choice of standard symbol.

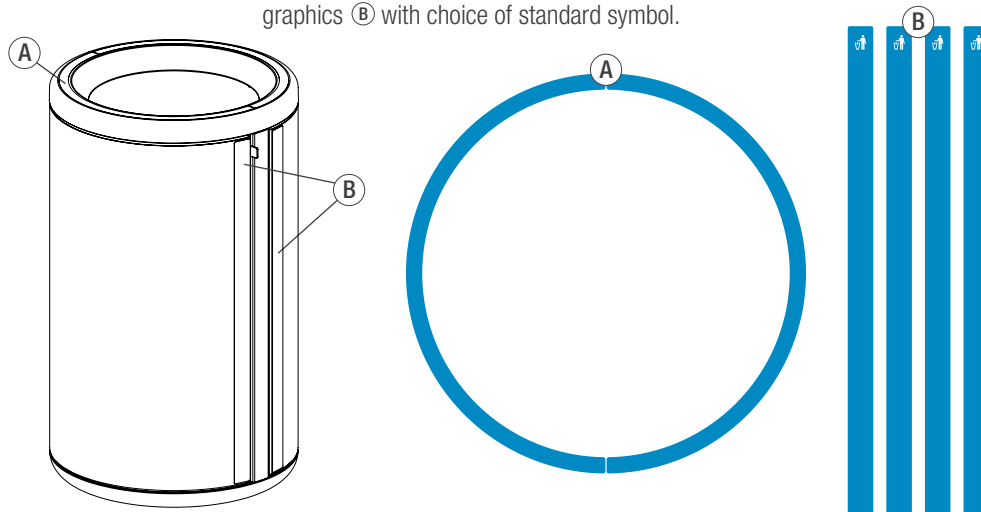

T 800.451.0410 | www.forms-surfaces.com

FORMS+SURFACES®

© 2021 Forms+Surfaces® | All dimensions are nominal. Specifications subject to change without notice. For the most current version of this document, please refer to our website at www.forms-surfaces.com



TONYO™ LITTER & RECYCLING RECEPTACLE

PRODUCT DATA

30- & 36-GALLON SPLIT-STREAM RECEPTACLE GRAPHICS (shown on 36-gallon receptacles)

Split-stream FSC 100% Cumaru configurations include trapezoid lid graphics (A) and (B) with choice of message/symbol, four horizontal door/body graphics (C) and (D) with symbols that correspond with each waste stream, and a top-of-lid two-tone graphic (E).

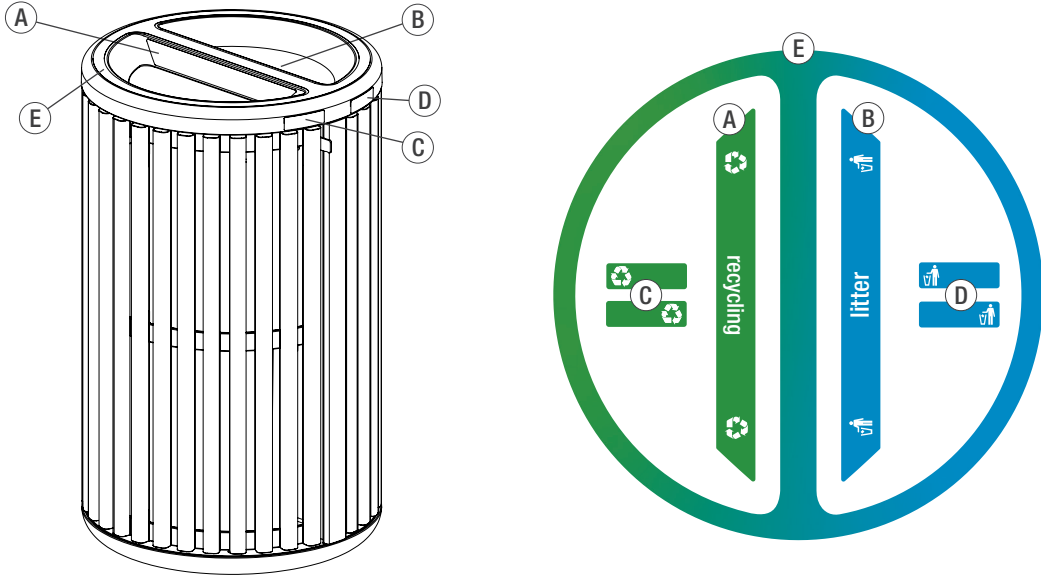

Split-stream stainless steel body/door configurations include trapezoid lid graphics (A) and (B) with choice of message/symbol, four vertical door/body graphics (C) and (D) with symbols that correspond with each waste stream, and a top-of-lid two-tone graphic (E).

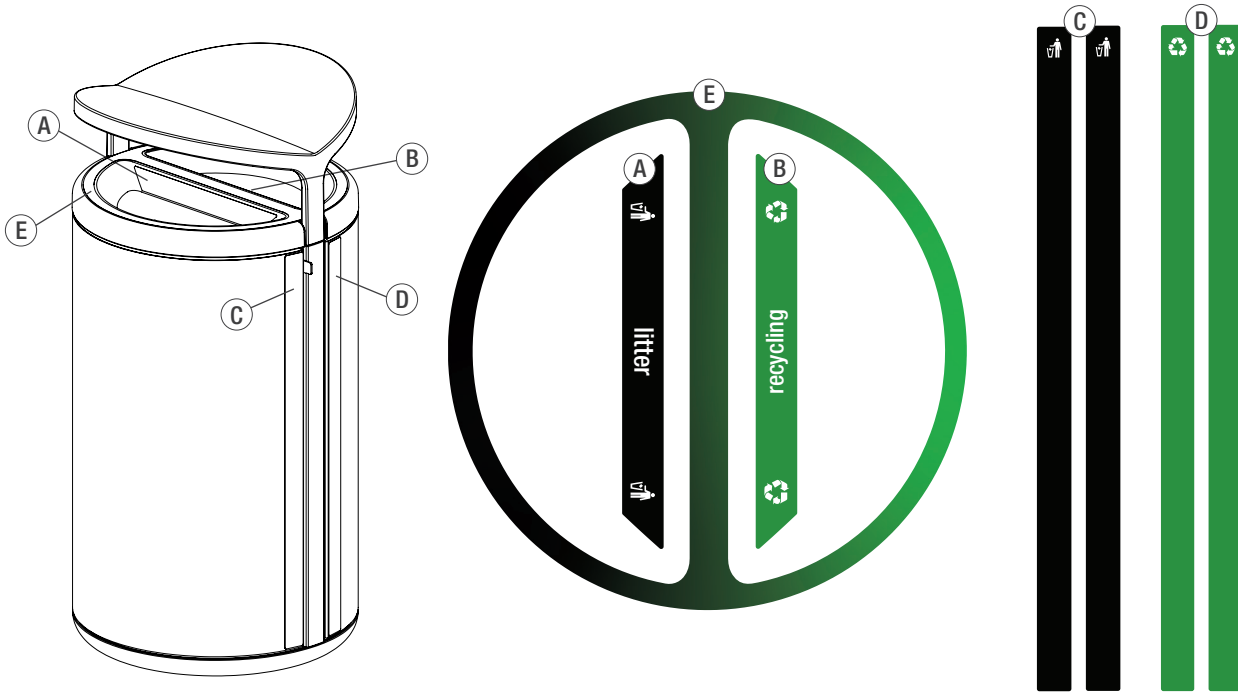



TONYO™ LITTER & RECYCLING RECEPTACLE

PRODUCT DATA

60-GALLON SPLIT-STREAM RECEPTACLE GRAPHICS

Split-stream FSC 100% Cumaru configurations include trapezoid lid graphics (A) and (B) with choice of message/symbol, four horizontal door/body graphics (C) and (D) with symbols that correspond with each waste stream, and a top-of-lid graphic (E) that is either two-tone or solid depending on waste stream choices.

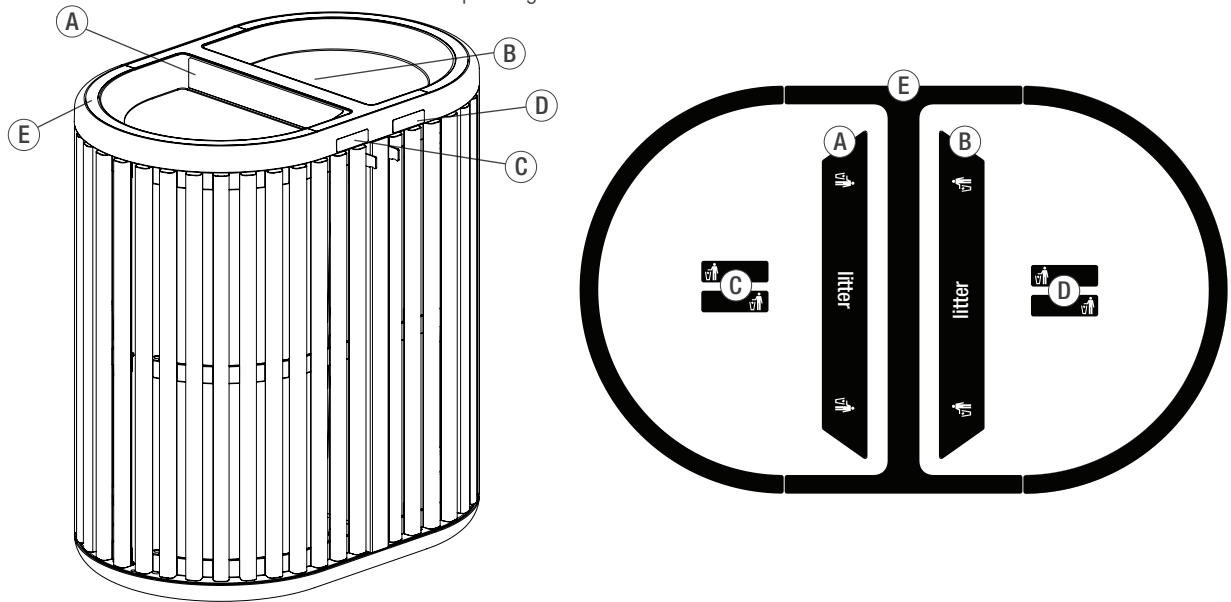

Split-stream stainless steel body/door configurations include trapezoid lid graphics (A) and (B) with choice of message/symbol, four vertical door/body graphics (C) and (D) with symbols that correspond with each waste stream, and a top-of-lid graphic (E) that is either two-tone or solid depending on waste stream choices.

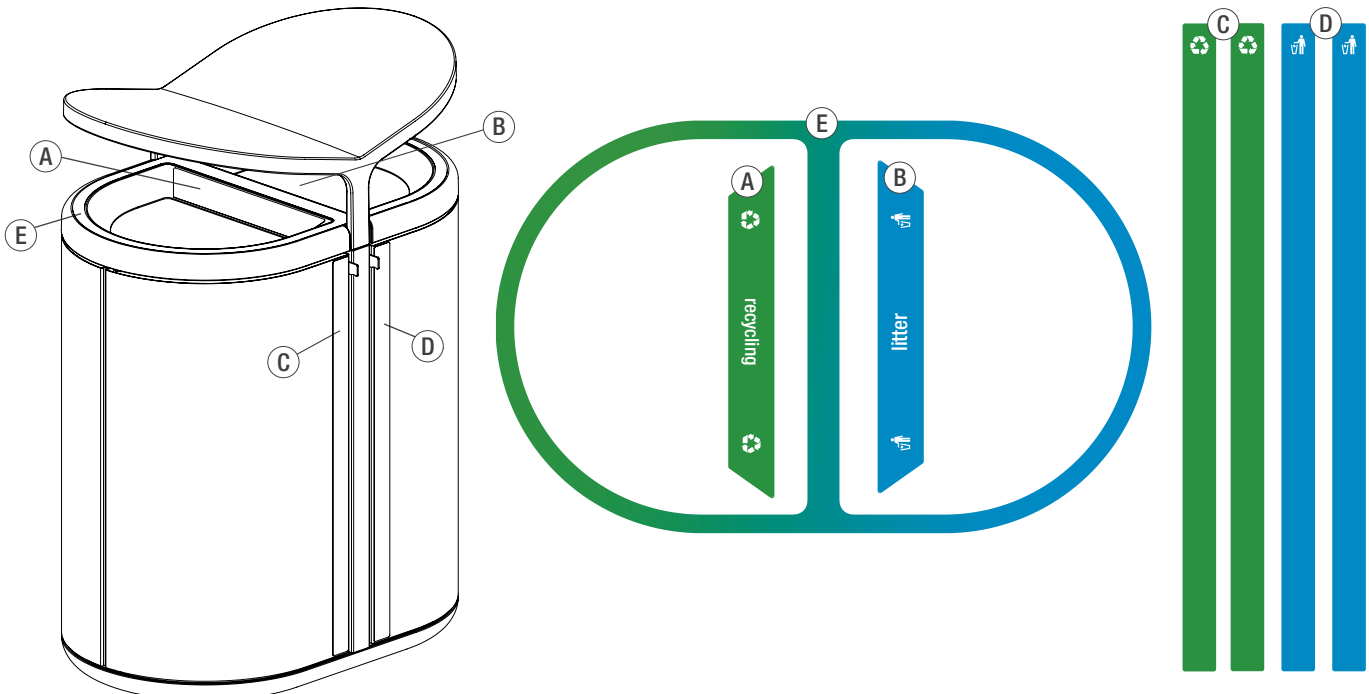

T 800.451.0410 | www.forms-surfaces.com

FORMS+SURFACES®

© 2021 Forms+Surfaces® | All dimensions are nominal. Specifications subject to change without notice. For the most current version of this document, please refer to our website at www.forms-surfaces.com



TONYO™ LITTER & RECYCLING RECEPTACLE

PRODUCT DATA

ENVIRONMENTAL CONSIDERATIONS

- Please refer to the Tonyo Receptacle Environmental Data Sheet for detailed environmental impact information.
- Components are fully recyclable.
- Low maintenance.
- Low- or no-VOC powdercoat.
- Cumaru hardwood slats certified FSC 100%.

MODEL NUMBERS AND DESCRIPTIONS

MODEL	DESCRIPTION
SLTNO-130C	Tonyo Receptacle, 30-gallon, single-stream, FSC® 100% Cumaru hardwood body/door
SLTNO-130S	Tonyo Receptacle, 30-gallon, single-stream, powdercoated stainless steel body/door
SLTNO-215C	Tonyo Receptacle, 30-gallon, split-stream, FSC® 100% Cumaru hardwood body/door
SLTNO-215S	Tonyo Receptacle, 30-gallon, split-stream, powdercoated stainless steel body/door
SLTNO-136C	Tonyo Receptacle, 36-gallon, single-stream, FSC® 100% Cumaru hardwood body/door
SLTNO-136S	Tonyo Receptacle, 36-gallon, single-stream, powdercoated stainless steel body/door
SLTNO-218C	Tonyo Receptacle, 36-gallon, split-stream, FSC® 100% Cumaru hardwood body/door
SLTNO-218S	Tonyo Receptacle, 36-gallon, split-stream, powdercoated stainless steel body/door
SLTNO-230C	Tonyo Receptacle, 60-gallon, split-stream, FSC® 100% Cumaru hardwood body/doors
SLTNO-230S	Tonyo Receptacle, 60-gallon, split-stream, powdercoated stainless steel body/doors

PRODUCT OPTIONS

The following options are available for an upcharge

Add rain hat (for 36- and 60-gallon models)	Upgrade to limited-access latch
Custom RAL powdercoat color	

LEAD TIME: 6 to 8 weeks. Shorter lead times may be available upon request. Please contact us to discuss your specific timing requirements.

PRICING: Please contact us at **800.451.0410** or **sales@forms-surfaces.com**. At Forms+Surfaces, we design, manufacture and sell our products directly to you. Our sales team is available to assist you with questions about our products, requests for quotes, and orders. Territory Managers are located worldwide to assist with the front-end specification and quoting process, and our in-house Project Sales Coordinators follow your project through from the time you place an order to shipment.

TO ORDER SPECIFY: Quantity, model, body/door material and finish, latch, and mounting options. Quote/Order Forms are available on our website to lead you through the specification process in a simple checkbox format.

NOTE: Because different computers will render colors and textures differently, actual colors and finishes may vary slightly from those shown here.