



TENSL™ UHPC

PRODUCT DATA

TENSL Ultra High Performance Concrete is over four times as strong as traditional precast concrete and performs exceptionally well in harsh conditions that cause most concrete to crack and degrade over time. TENSL cast elements have an intrinsic finish that weathers over time to a natural patina that is slightly lighter in color.

UHPC VERSUS TRADITIONAL CONCRETE

UHPC, or Ultra High Performance Concrete, is a class of concrete defined by its exceptionally high strength and durability. UHPC does not absorb water and therefore does not degrade due to freeze/thaw or marine conditions.

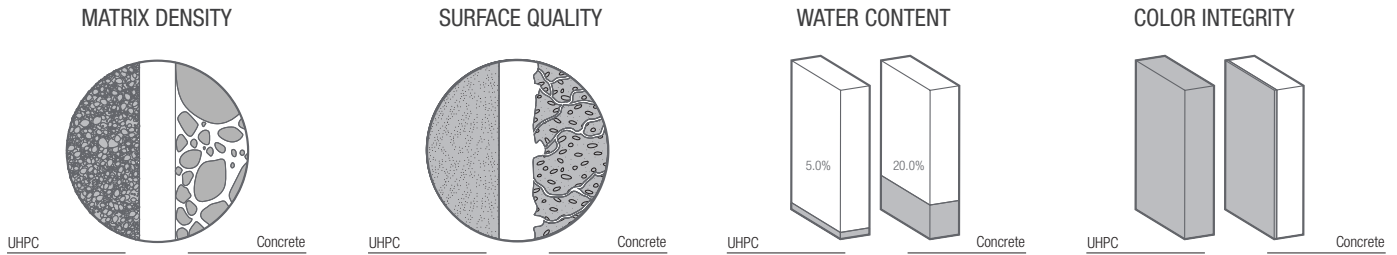

UHPC STRENGTH

TENSL UHPC consists of densely packed molecules that are highly bonded which results in excellent flexural strength, and it is reinforced with alkali resistant glass fiber to optimize performance. This allows it to be cast in very thin profiles over long spans and far less material is needed to achieve the same structural requirements. TENSL UHPC is structurally more comparable to steel than traditional concrete. The diagrams below detail amount of material needed to achieve the equivalent structural strength for UHPC and other traditional building materials.

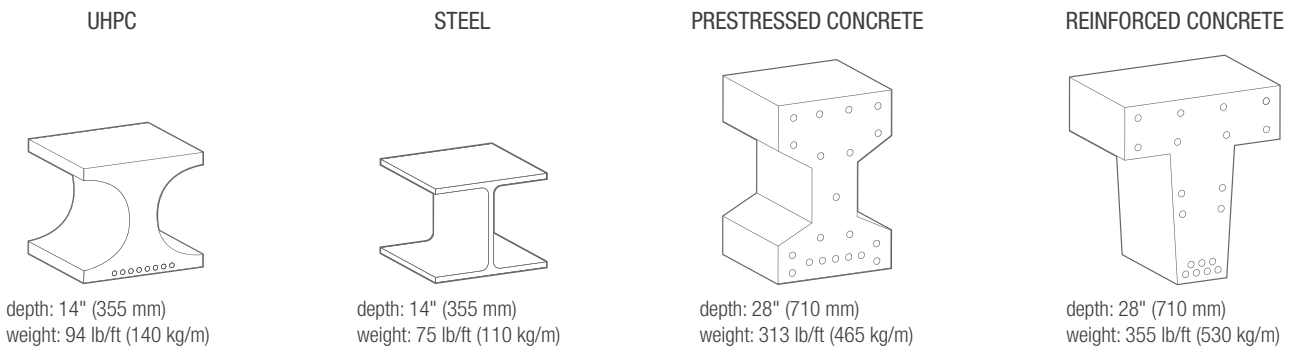

TENSL gains most of its strength in the first month after it is cast; however, it actually continues to cure for several years and becomes even stronger during that time. This continued strength development consists primarily of hydration within the material – water molecules creating additional bonding within the cement – and the material will therefore also interact with water in the environment, weathering evenly over time to achieve its final patina.