



**Name:** MAR

**Design:** Taller/Estudi Bover / 2004

**Typology:** Pendant lamp

**Environment:** Indoor

**Technical description:**

Rectangular pendant lamp available in various finish combinations: satin nickel with transparent wire, satin nickel with red tensor wire, dark leather with transparent wire, or caramel colored cuir leather with transparent wire. Polycarbonate diffuser is held in place by four hooks; diffuser is included with fixture. Rectangular lamp shade is available in cream, white or red translucent hand wrapped polyester blend ribbon, or white classic cotton.



**Lamps description**

Earthing: compulsory

Ready for mounting on normally flammable surface

3 x 42 W Classic P ECO E-27

3 x 11 W E-27

**Voltage:** 230V~50Hz

1 Box 35 x 45 x 165 cm

**Vol.:** 0,2599 m<sup>3</sup>

**Weight:** 5 kg

**Certifications:** Intertek 4006618

**Ref** **Finishings**

4324405T	Nickel transparent wire
4324405R	Nickel red wire
4324460	Dark leather transparent wire
4324461	Cuir leather transparent wire

Rectangular lampshade 100 x 17 cm  
Diffuser included

P-521	Cream translucent ribbon
P-522	White translucent ribbon
P-523	Red translucent ribbon
P-524	Cotton

**IMPORTANT NOTE: Standard 4.75" square cover plate for junction box mount included.**

**Customizable**

**Measures**

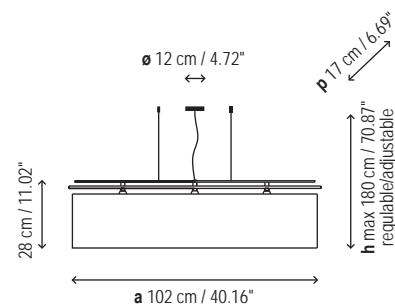

**Project information**

Project name:	Approved by:
Fixture type:	Date:
Location:	Prepared by:
Comments:	Prepared for:

**Photometrics**