

indoor

Nautica Swing chair / columpio

MUT Design, 2012

T060



Swing chair with structure made of peeled and tinted natural rattan 34 mm/1.33" in diameter. Backrest manufactured in peeled and tinted natural rattan 24 mm/0.94" in diameter. Finished with a three step coating (dye, base coat and top coat) highly resistant to solar radiation thanks to UV filters. Cushion upholstered in natural or faux leather, virgin wool fabrics, velvet and polypropylene. Braided polyester rope with 14 mm/0.55" of section is provided to hang the swing chair. Optional anti-swing (braided polyester rope + carabiner). Base manufactured in aluminum tube with 45 mm/1.77" of section. Adjustable plastic caps.

Columpio con estructura en rattan natural pelado y tintado de 34 mm de calibre. Respaldo fabricado en rattan natural pelado y tintado de 24 mm de calibre. Acabado con recubrimiento en tres fases (tinte, fondo y acabado) con filtros UV que lo hacen altamente resistente a la radiación solar. Cojines tapizados en piel natural o sintética, tejidos de lana virgen, terciopelo y polipropileno. Cuerda de poliéster de 14 mm de sección suministrada, necesaria para colgar el columpio. Anti-swing opcional (cuerda de poliéster + mosquetón). Base fabricada en tubo de aluminio de 45 mm de sección. Tacos reguladores de plástico.

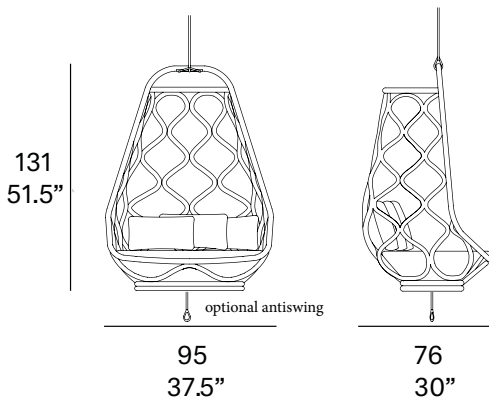

Shipment details

Qty	1 armchair (1 box)
Volume	1,04 m3 / 36.73 ft3
Gross weight	19 kg / 42 lb
Net weight	14 kg / 31 lb
Item dimensions (width x depth x height)	117 x 114 x 195 cm 37.5" x 30" x 51.5"
COM (1, 40 - 1,50 m / 54"-59")	1,80 + 1,5 m / 1.90 yd + 1.60 yd

Certifications

UNE EN 581-1:2006
UNE EN 581-2:2016

Awards



reddot award 2014
winner

expormim

Expormim S.A.
Pol. Ind. Jaime I
46640 Mogente (Valencia) Spain
+34 962 295 144/5
export@expormim.com
www.expormim.com

Expormim USA LLC
(212) 204-8572
usa@expormim.com
www.expormim.com

1/5