

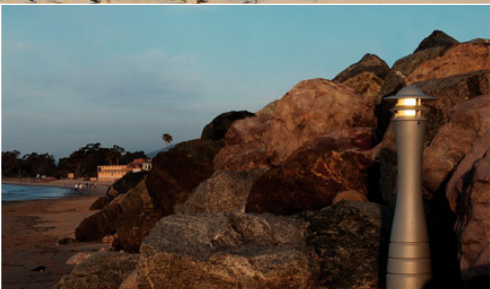

**TRIADA™** BOLLARD

PRODUCT DATA

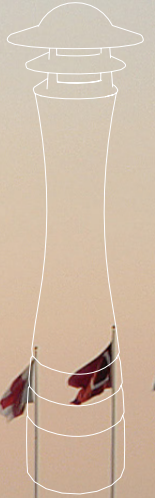



Triada Bollards are designed to look great in both traditional and contemporary settings. The louvered head and expressively shaped column are rustproof cast aluminum with a powdercoat finish. White or amber LED lamping and optional directional shields satisfy a wide range of illumination scenarios. Remarkably durable and causally nautical, Triada performs beautifully in coastal environments and outdoor settings of all kinds.

**MATERIAL & CONSTRUCTION DETAILS**

**INSTALLATION & MAINTENANCE**

MATERIALS & FINISHES	LED LAMPS & DRIVERS	INSTALLATION
<ul style="list-style-type: none"> <li>• Triada Bollard body is made from corrosion-resistant solid cast aluminum with a powdercoat finish.</li> <li>• See the Forms+Surfaces Powdercoat Chart for details. Custom RAL colors are available for an upcharge.</li> <li>• Head is a three-part cast aluminum assembly powdercoated to match the body, with frosted borosilicate glass cylinder and gasketed top and bottom.</li> <li>• Due to the inherent nature of metal castings, gloss powdercoats are not offered for cast components.</li> </ul>	<ul style="list-style-type: none"> <li>• Features advanced LED technology with 34W, 4000K natural white and 42W Amber LEDs. See lamp information on page 2.</li> <li>• LED electronic driver: input power is 90-305V, -30 °C starting temperature, can be specified as dimmable.</li> <li>• Driver has 0-10V dimming capabilities.</li> <li>• LED driver certifications include: IP66 (waterproof), Class A sound rating.</li> </ul>	<ul style="list-style-type: none"> <li>• Standard mounting is surface mount with 1/2"-13x18" galvanized steel J-bolt anchors and 1/2" thick aluminum base plate.</li> <li>• Installation of a surge protector as part of each units wiring is recommended.</li> <li>• Necessary hardware is included. Templates are available upon request.</li> </ul>
WEIGHT	SHIELD OPTION	MAINTENANCE
<ul style="list-style-type: none"> <li>• 56 lbs (25 kg)</li> </ul>	<ul style="list-style-type: none"> <li>• Custom shield designs are available with either 180° or 270° coverage.</li> </ul>	<ul style="list-style-type: none"> <li>• Metal surfaces can be cleaned as needed using a soft cloth or brush with warm water and a mild detergent. Avoid abrasive cleaners.</li> </ul>

**NOMINAL DIMENSIONS**

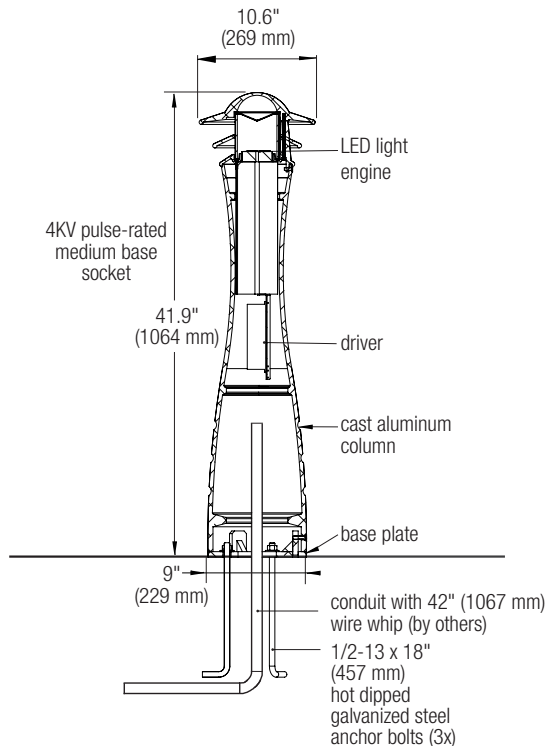

**BASE PLATE MOUNTING DETAIL**

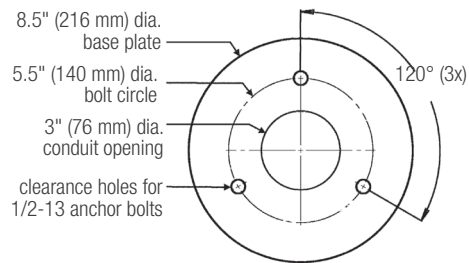



**LAMP DESCRIPTIONS**

LAMP	DESCRIPTION	COLOR TEMPERATURE	LUMINAIRE LUMENS*	B.U.G. RATING	STARTING TEMPERATURE °C
4000K LED	34W LED light engine	4,000K	please call	please call	-30
Amber LED	42W LED light engine	Amber**	676	B1-U2-G1	-30

\*Luminaire lumens represents the absolute photometry for the luminaire, and indicates the lumens out of the entire fixture.

\*\*Amber LED meets Florida Fish and Wildlife Conservation Commission (FWC) requirements for wavelength in sea turtle nesting habitats. The peak wavelength for Amber LED is 591nm.

**NOTE: Polar candela and isofootcandle plots can be found on the Triada Bollard product page on our website.**

**CERTIFICATIONS**

- ETL and C-ETL listed for wet locations.

**ENVIRONMENTAL CONSIDERATIONS**

- Please refer to the Triada Bollard Environmental Data Sheet for detailed environmental impact information.
- Triada Bollard has high recycled content and is highly recyclable.
- Powdercoat finishes are no- or low-VOC, depending on color.
- Low maintenance.

**MODEL NUMBERS AND DESCRIPTIONS**

MODEL	DESCRIPTION
LBTRI-LED	Triada Bollard, LED

**PRODUCT OPTIONS**

The following options are available for an upcharge

Standard Texture Colors from Forms+Surfaces Powdercoat Chart	Custom RAL powdercoat color
--	-----------------------------

**LEAD TIME:** 6 to 8 weeks. Shorter lead times may be available upon request. Please contact us to discuss your specific timing requirements.

**PRICING:** Please contact us at **800.451.0410** or **sales@forms-surfaces.com**. At Forms+Surfaces, we design, manufacture and sell our products directly to you. Our sales team is available to assist you with questions about our products, requests for quotes, and orders. Territory Managers are located worldwide to assist with the front-end specification and quoting process, and our in-house Project Sales Coordinators follow your project through from the time you place an order to shipment.

**TO ORDER SPECIFY:** Quantity, model, powdercoat color and lamp. Quote/Order Forms are available on our website to lead you through the specification process in a simple checkbox format.