



**CORDIA™ PEDESTRIAN**

PRODUCT DATA





**Cordia Pedestrian Lighting** has a graceful design that blends a unique sense of style with optimal light output and LED performance. Fixture body and base are durable aluminum with a powdercoat finish; lens is tempered glass. Cordia Pedestrian Lighting coordinates with Cordia Bollards and the rest of the Cordia line and can be used to bring a contemporary twist to even the most traditional landscape settings

**MATERIAL & CONSTRUCTION DETAILS**

**INSTALLATION & MAINTENANCE**

CONSTRUCTION	LED & DRIVER	INSTALLATION
<ul style="list-style-type: none"> <li>• Head consists of corrosion-resistant cast aluminum and a tempered glass lens.</li> <li>• Body is made from corrosion-resistant cast aluminum with a powdercoat finish.</li> <li>• Base is made from corrosion-resistant aluminum with a powdercoat finish.</li> <li>• 110 lbs.</li> </ul>	<ul style="list-style-type: none"> <li>• Features advanced LED technology with 75W, 3000K warm white or 4000K neutral white LED.</li> <li>• LED chip is mounted to an extruded aluminum heat sink.</li> <li>• LED driver input power is 100 - 277 VAC.</li> <li>• Driver has 0-10V dimming capabilities.</li> </ul>	<ul style="list-style-type: none"> <li>• 0.75" thick structural aluminum base plate with cast aluminum base cover and 3/4"-10x24" galvanized steel J-bolt anchors.</li> <li>• Installation of a surge protector as part of each units wiring is recommended.</li> <li>• Necessary hardware is included. Templates available upon request.</li> </ul>
FINISH	LENS, VISIBILITY & SHIELD OPTIONS	MAINTENANCE
<ul style="list-style-type: none"> <li>• See the Forms+Surfaces Powdercoat Chart for details. Custom RAL colors are available for an upcharge.</li> <li>• Due to the inherent nature of metal castings, gloss powdercoats are not offered for cast components.</li> </ul>	<ul style="list-style-type: none"> <li>• Includes a tempered glass lens.</li> <li>• Pedestrian emits light with a 360° visibility.</li> </ul>	<ul style="list-style-type: none"> <li>• Metal surfaces can be cleaned as needed using a soft cloth or brush with warm water and a mild detergent. Avoid abrasive cleaners.</li> </ul>

**NOMINAL DIMENSIONS**

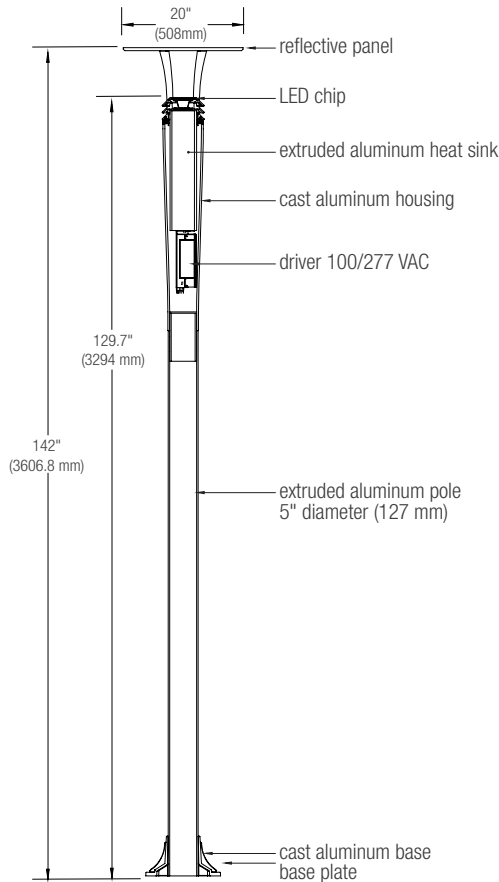

**BASE PLATE MOUNTING DETAIL**

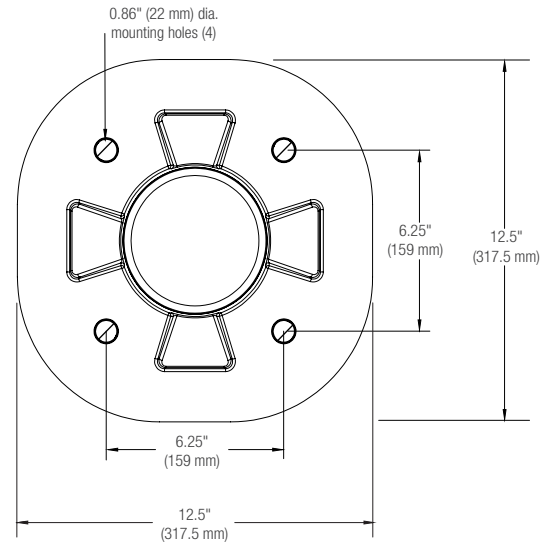





## CORDIA™ PEDESTRIAN

PRODUCT DATA

### LIGHT ENGINE DESCRIPTION

LAMPS	DRIVER	LUMINAIRE LUMENS*	B.U.G. RATING	CLASSIFICATION
3000K LED	75W	5323	B1-U2-G1	TYPE V
4000K LED	75W	5323	B1-U2-G1	TYPE V

\*LED lumens represents the absolute photometry for the luminaire, and indicates the lumens out of the entire fixture.

**NOTE: Polar candela and isofootcandle plots can be found on the Cordia Pedestrian product page on our website.**

### CERTIFICATION

- ETL and C-ETL listed for wet locations.

### ENVIRONMENTAL CONSIDERATIONS

- Please refer to the Cordia Pedestrian Lighting Environmental Data Sheets for detailed environmental impact information.
- Metal components have a long life cycle and are 100% recyclable.
- Standard powdercoat finishes are no-VOC; non-standard powdercoat finishes are no- or low-VOC, depending on color.
- Low maintenance; easy to disassemble.

### MODEL NUMBERS AND DESCRIPTIONS

MODEL	DESCRIPTION
LPCOR-LED	Cordia Pedestrian, LED

### PRODUCT OPTIONS

The following options are available for an upcharge

Custom RAL powdercoat color
-----------------------------

**LEAD TIME:** 6 to 8 weeks. Shorter lead times may be available upon request. Please contact us to discuss your specific timing requirements.

**PRICING:** Please contact us at **800.451.0410** or **sales@forms-surfaces.com**. At Forms+Surfaces, we design, manufacture and sell our products directly to you. Our sales team is available to assist you with questions about our products, requests for quotes, and orders. Territory Managers are located worldwide to assist with the front-end specification and quoting process, and our in-house Project Sales Coordinators follow your project through from the time you place an order to shipment.

**TO ORDER SPECIFY:** Quantity, powdercoat color and color temperature. Quote/Order Forms are available on our website to lead you through the specification process in a simple checkbox format.