

Classical Basin Stands	
Troon	Twin Marble Console

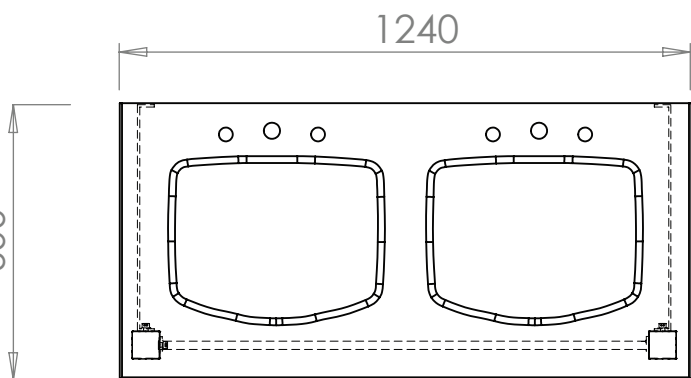

Note: Single basin marble top also available

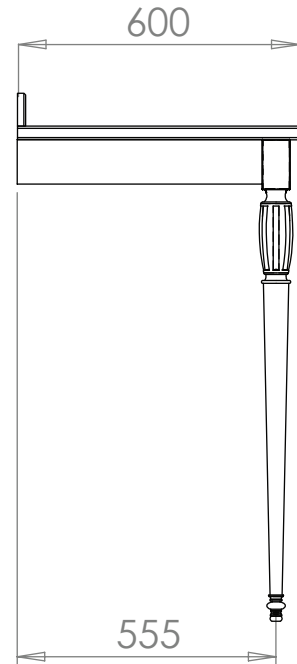
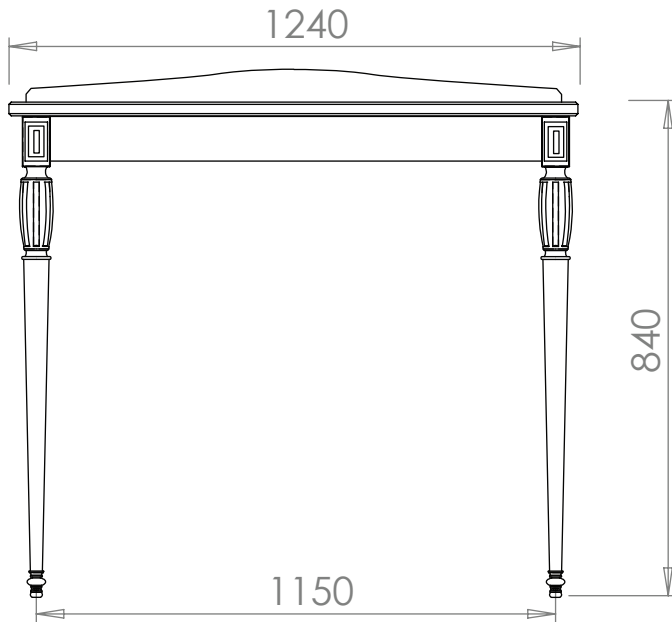
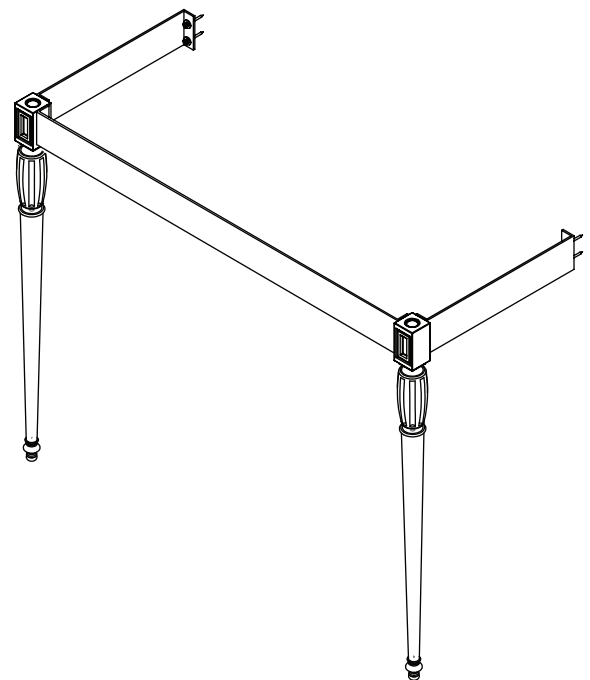

We recommend that all products are purchased with the assistance of a specialist bathroom retailer and always installed by an experienced installer who is a member of a recognized association. All sizes quoted are nominal: items may vary by plus or minus 2% against the figures quoted. When planning installations where dimensions are critical, it is essential that the space allowed for individual items is physically checked. Imperial Bathrooms can not be held liable for any costs associated with items not fitting in any given area. The contents of this statement are based on information correct at the time of publication. We reserve the right to make alterations and changes in product characteristics, fixing, packaging, operation etc at any time without notice.

For further information on fitting guidelines, Terms and Conditions and Warrantee details, please refer to the back of the 2008 Design Guide or contact Imperial's Customer Service team on 0870 60 61 62 3 or sales@imperial-bathrooms.co.uk

Ceramic Collection	
Radcliffe	Underslung basin

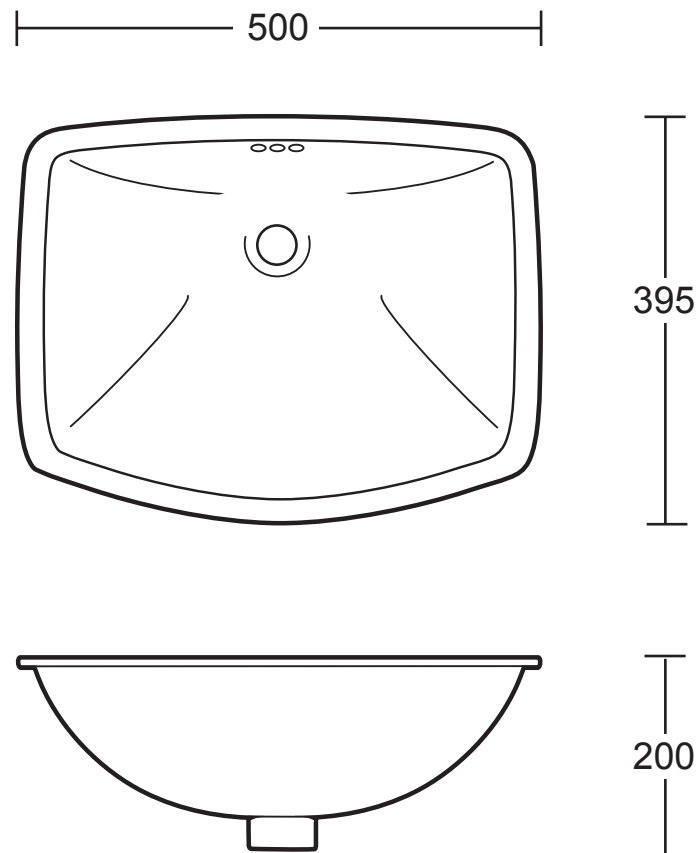

We recommend that all products are purchased with the assistance of a specialist bathroom retailer and always installed by an experienced installer who is a member of a recognized association. All sizes quoted are nominal: items may vary by plus or minus 2% against the figures quoted. When planning installations where dimensions are critical, it is essential that the space allowed for individual items is physically checked. Imperial Bathrooms can not be held liable for any costs associated with items not fitting in any given area. The contents of this statement are based on information correct at the time of publication. We reserve the right to make alterations and changes in product characteristics, fixing, packaging, operation etc at any time without notice.

For further information on fitting guidelines, Terms and Conditions and Warrantee details, please refer to the back of the 2008 Design Guide or contact Imperial's Customer Service team on 0870 60 61 62 3 or sales@imperial-bathrooms.co.uk

Classical Basin Stands

Troon/Adare	Twin Marble Top
-------------	-----------------

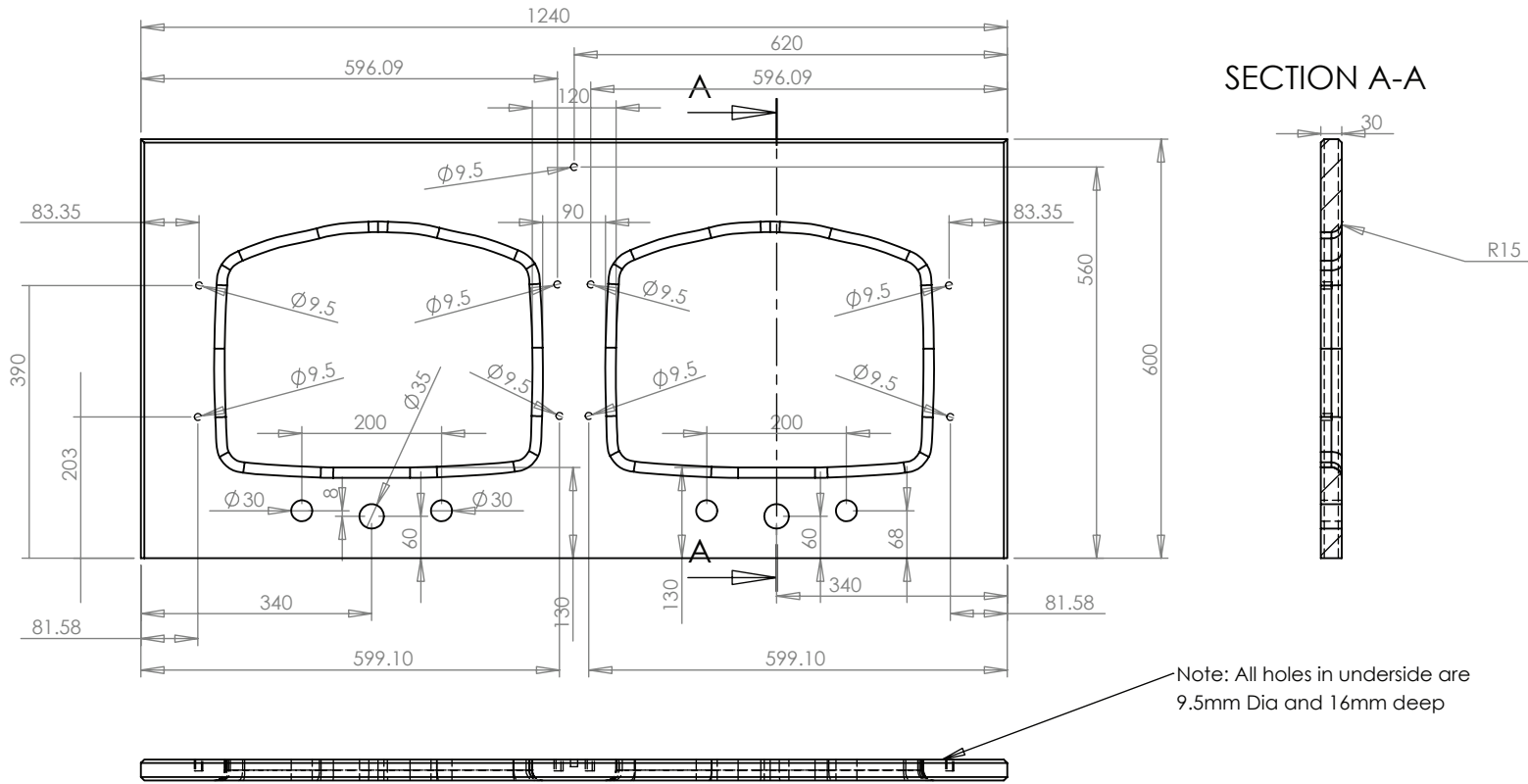

We recommend that all products are purchased with the assistance of a specialist bathroom retailer and always installed by an experienced installer who is a member of a recognized association. All sizes quoted are nominal: items may vary by plus or minus 2% against the figures quoted. When planning installations where dimensions are critical, it is essential that the space allowed for individual items is physically checked. Imperial Bathrooms can not be held liable for any costs associated with items not fitting in any given area. The contents of this statement are based on information correct at the time of publication. We reserve the right to make alterations and changes in product characteristics, fixing, packaging, operation etc at any time without notice.

For further information on fitting guidelines, Terms and Conditions and Warrantee details, please refer to the back of the 2008 Design Guide or contact Imperial's Customer Service team on 0870 60 61 62 3 or sales@imperial-bathrooms.co.uk

Classical Basin Stands	
Troon/Adare	Twin Marble Backsplash

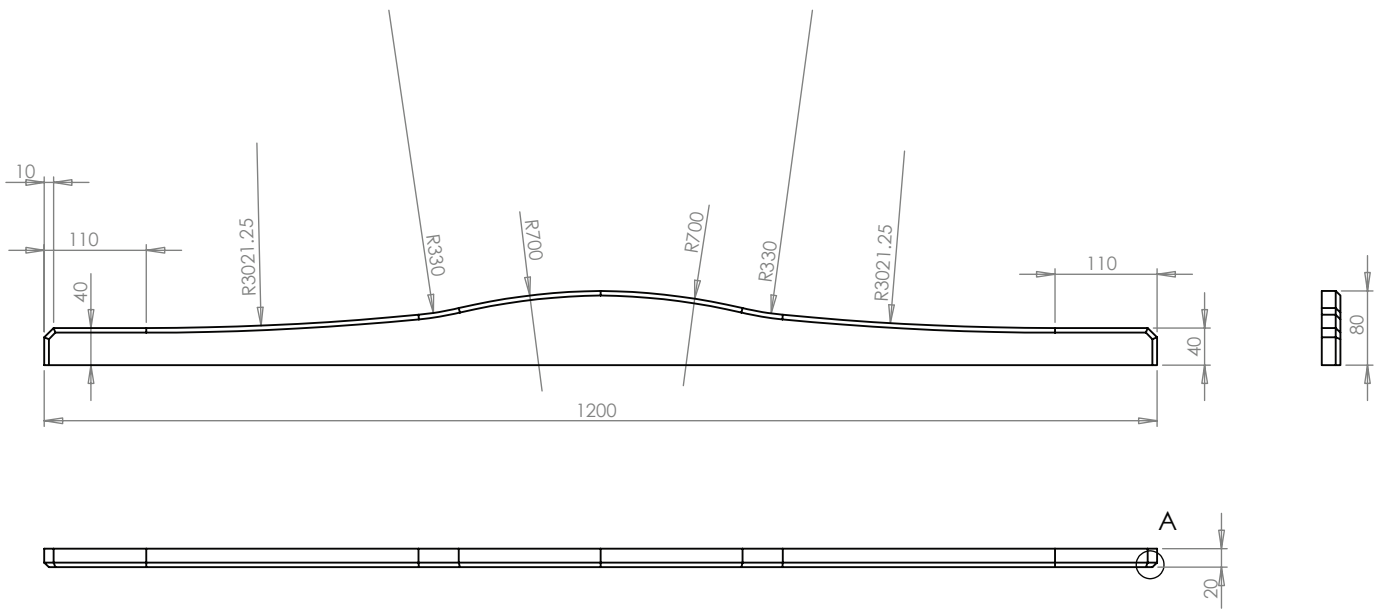

NOTE: Chamfer detail 45degrees 5mm

DETAIL A
SCALE 2 : 5

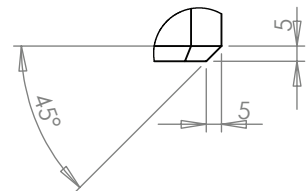

We recommend that all products are purchased with the assistance of a specialist bathroom retailer and always installed by an experienced installer who is a member of a recognized association. All sizes quoted are nominal: items may vary by plus or minus 2% against the figures quoted. When planning installations where dimensions are critical, it is essential that the space allowed for individual items is physically checked. Imperial Bathrooms can not be held liable for any costs associated with items not fitting in any given area. The contents of this statement are based on information correct at the time of publication. We reserve the right to make alterations and changes in product characteristics, fixing, packaging, operation etc at any time without notice.

For further information on fitting guidelines, Terms and Conditions and Warrantee details, please refer to the back of the 2008 Design Guide or contact Imperial's Customer Service team on 0870 60 61 62 3 or sales@imperial-bathrooms.co.uk

Customer Information

NB: If you are the installer of this product, please be sure to pass this 'Customer Information' sheet to the end user/consumer.

Congratulations, you are now the proud owner of an individual and unique hand-made stone or marble wash-basin or counter-top. Please take the time to read the information provided for you below; it gives notes and guidance to maintain a long life with trouble-free performance from your new purchase.

Due to stone being a natural material and the handmade nature of our products, minor variations in colour, shading and size of inclusions are to be expected. With occasional fossils, vein pits and pores and no two pieces exactly alike, these naturally occurring variations do not constitute grounds for claim or return. Please inspect each packet carefully. Use of stone constitutes full acceptance of the products.

Each bowl has been hand-made from a solid piece of natural stone and is made to emulate a rustic chiselled piece; as such, you should expect each piece to be somewhat pitted, pock-marked, scarred and blemished – this gives each piece its own individual character and uniqueness and is not a reflection of poor quality or sub-standard materials and craftsmanship. Similarly, since each piece is hand-made, you should expect some small deviations in dimensional sizes from those shown in the brochure.

Cutting and Drilling

Stone can be cut with a wet diamond saw equipped with a continuous rim blade. Smooth any rough edges with sand paper or sanding stone.

Cleaning and Maintenance

Natural stone requires different cleaning and maintenance materials and procedures to ceramic products. Stone should only be cleaned with water and neutral pH cleaners. Stone cleaners must not contain acid or bleach. Even diluted acidic cleaners will damage the sealer and stone surface. Avoid all abrasive cleaners which may permanently scratch or damage the tile surface. All marble should be sealed with penetrating waterproof Sealer after installation and periodically as needed. For marble or stone countertops, wipe up any remaining water off the surface of the counter after use. Over time water can leave behind calcium mineral deposits. When installing drains and fittings on marble countertops only use 100% silicone or marble safe plumbers putty. The use of incorrect putty will result in stained marble and void the warranty.

To assist you in use, each piece of stone/marble has already been pre-sealed but will require regular maintenance with appropriate care and sealant products. We have used a special impregnation which optimally protects absorbent, stain-sensitive natural stone surfaces. It largely prevents the penetration of oil, grease, and water and makes further maintenance easier.

Using the right on going care products will facilitate the cleaning process and will maintain a fresher appearance of your stone surfaces. We recommend that you re-treat your purchase on a quarterly or six-monthly basis dependent upon use. For very heavy use (restaurants, hotels, etc.), we recommend even more frequent applications.

Stone care products should always be tested as to their effectiveness and their compatibility to the surface in a small, inconspicuous area. All surfaces should be regularly cleaned using only a soft, lint-free damp cloth – avoid all abrasive and chemical cleaning materials.

Marble and other limestone's will be damaged when exposed to acidic substances (cement residue remover, bathroom cleaners, vinegar, ketchup, wine, cola, fruit juices, etc.) – please avoid. Also be aware that marble and limestone, etc. can be easily scratched – avoid contact with hard surfaces such as metal, unglazed ceramics, jewellery etc.

For more extraordinary kinds of dirt and blemishes (e.g. paint, wax, grease, oil, tar, algae, etc.) you should only use special proprietary cleaning products. These are readily available from specialist outlets. For further guidance, we recommend that you contact 'Lithofin' at www.lithofin.co.uk.

Note: As with all hand basins and bowls (ceramic, stone and marble), boiling water should never be used – this can cause failure and may lead to injury.