

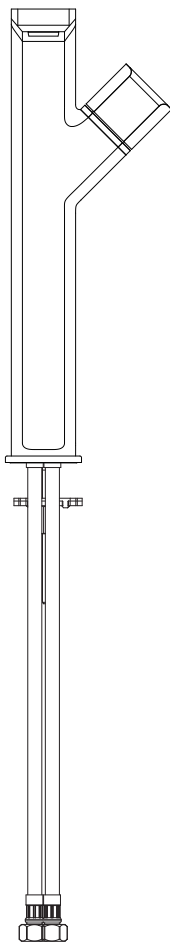

NEO



EAN CODE : 3276000495017/3276000495024
3276000654124/3276000654148

FR Manuel d'Instructions

ES Manual de Instrucciones

PT Manual de Instruções

IT Manuale di Istruzioni

EL Εγχειρίδιο Οδηγών

PL Instrukcja Obsługi

RU Руководства по
Эксплуатации

KZ Пайдаланушы Нұсқаулығы

UA Інструкція з Експлуатації

RO Manual de Instrucțiuni

BR Manual de Instruções

EN Instructions Manual

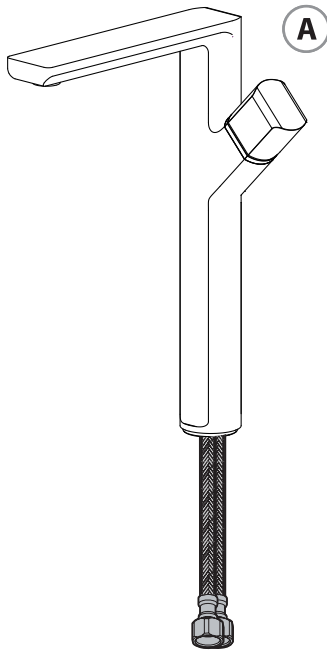
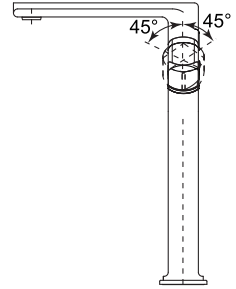
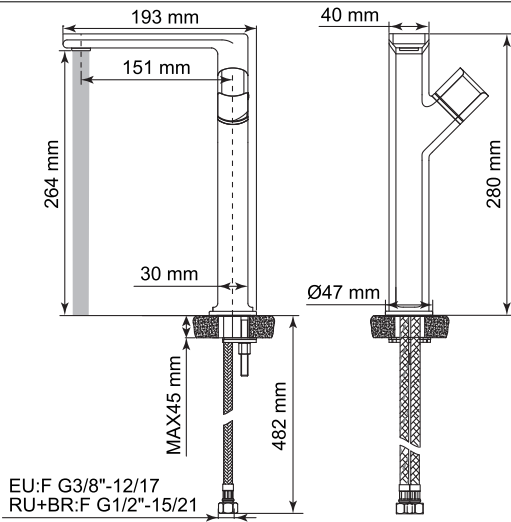

B



C



D

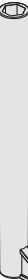

E



F



G



2,5mm



PH2





Nettoyage / Limpieza / Limpeza / Pulizia / Καθαρισμός / Czyszczenie / Чистка / Очищення / Curățare / Cleaning



Eau claire / Agua limpia / Água limpa / Acqua pulita / Καθαρό νερό / Czysta woda / Чистая вода / Чиста вода /
Apă curată / Clean water



Sans solvant / Sin disolvente / Sem solventes / Senza solventi / Χωρίς διαλυτικά / Bez rozpuszczalnika / Без растворителя /
Без розчинника / Fără solvent / Solvent-free



FR: Préparation / **ES:** Preparación / **PT:** Preparação / **IT:** Preparazione / **EL:** Προετοιμασία /
PL: Przygotowanie / **RU:** Подготовка / **KZ:** Дайындау / **UA:** Підготування / **RO:** Pregătire / **BR:** Preparação /
EN: Preparation



FR: Montage / **ES:** Montaje / **PT:** Montagem / **IT:** Montaggio / **EL:** Συναρμολόγηση /
PL: Montaż / **RU:** Сборка / **KZ:** Монтаждау / **UA:** Збірка / **RO:** Montaj / **BR:** Montagem /
EN: Assembly



FR: Utilisation eau chaude-eau froide/ **ES:** Utilización agua caliente-agua fría/
PT: Utilização água quente-água fria/ **IT:** Uso acqua calda-acqua fredda/ **EL:** Χρήση ζεστού-κρύου νερού/
PL: Użytkowanie zimnej wody-gorącej wody/ **RU:** Використання гарячої води/
KZ: Суық және ыстық суды қолдану/ **UA:** води - холодної води/ **RO:** Utilizare apă caldă-apă rece/
BR: Uso de água quente e fria/ **EN:** Using hot and cold water



FR: Changement de cartouche/ **ES:** Cambio de cartucho/ **IT:** Cambio cartuccia/
PT: Mudança de cartucho/ **EL:** Αλλαγή φυσιγγίου/ **PL:** Wymiana wkładu / **RU:** Смена картриджа/
KZ: Картриджді ауыстыру/ **UA:** Заміна картриджа/ **RO:** Schimbare cartuş/
BR: Substituição de cartucho/ **EN:** Replacing the cartridge



FR: Changement de mousseur/ **ES:** Cambio de aireador/ **PT:** Mudança de arejador/
IT: Cambio rompigetto/ **EL:** Αλλαγή αεράτορα / **PL:** Wymiana perlatora / **RU:** Смена аэратора/
KZ: Ауақанықтырғышты ауыстыру/ **UA:** Заміна аэратора/ **RO:** Schimbare aerator/
BR: Substituição do aerador/ **EN:** Replacing the aerator



FR: Changement de flexibles/ **ES:** Cambio de flexibles / **PT:** Mudança de flexíveis/
IT: Cambio flessibili/ **EL:** Αλλαγή λάστιχων/ **PL:** Wymiana wężyków instalacyjnych /
RU: Смена гибкого шланга для смесителя/ **UA:** Заміна гнучкого шланга для змішувача/
KZ: Қоспалауышқа арналған иілгіш шлангты ауыстыру/ **RO:** Schimbare furtune flexibile/
BR: Substituição das mangueiras/ **EN:** Replacing the hoses





FR: Préparation / ES: Preparación / PT: Preparação / IT: Preparazione / EL: Προετοιμασία /
PL: Przygotowanie / RU: Подготовка / KZ: Дайындау / UA: Підготування / RO: Pregătire /
BR: Preparação / EN: Preparation

1

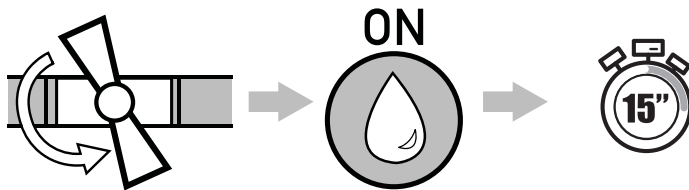

2

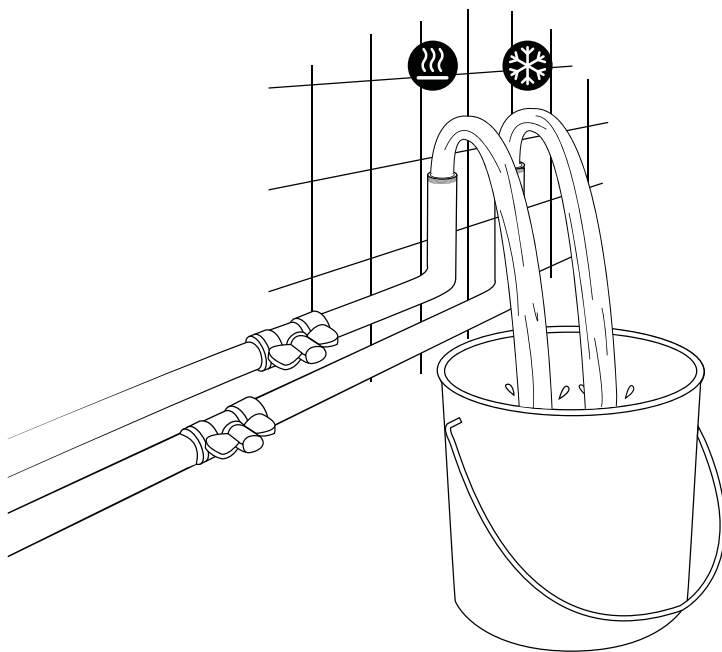

3

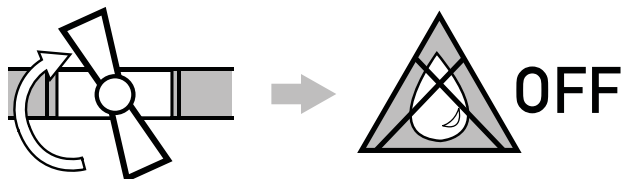

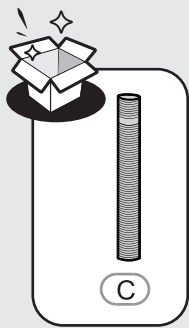

FR: Montage / ES: Montaje / PT: Montagem / IT: Montaggio / EL: Συναρμολόγηση /
PL: Montaż / RU: Сборка / KZ: Монтаждау / UA: Збірка / RO: Montaj / BR: Montagem /
EN: Assembly

1

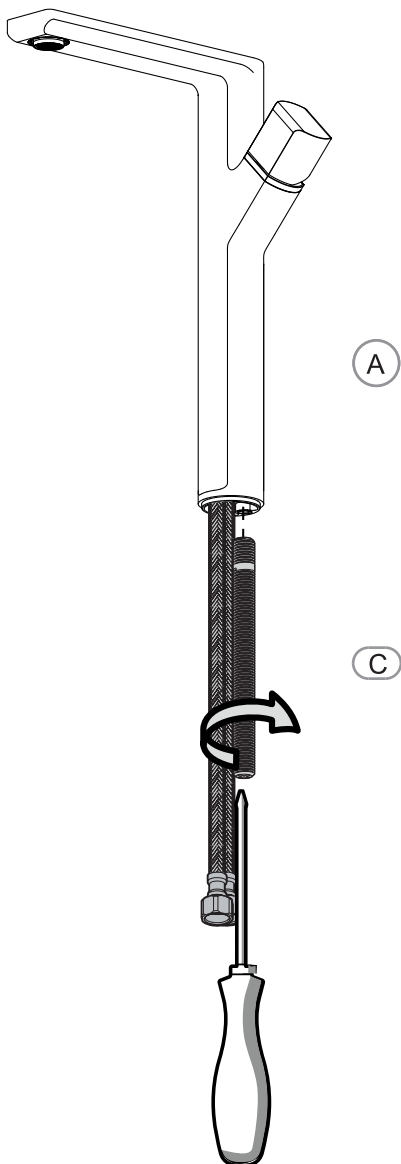
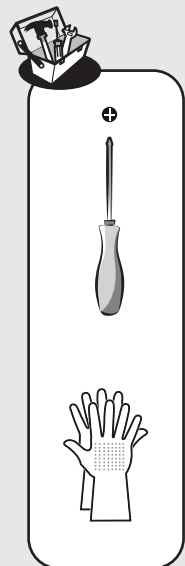

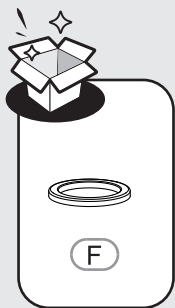

2

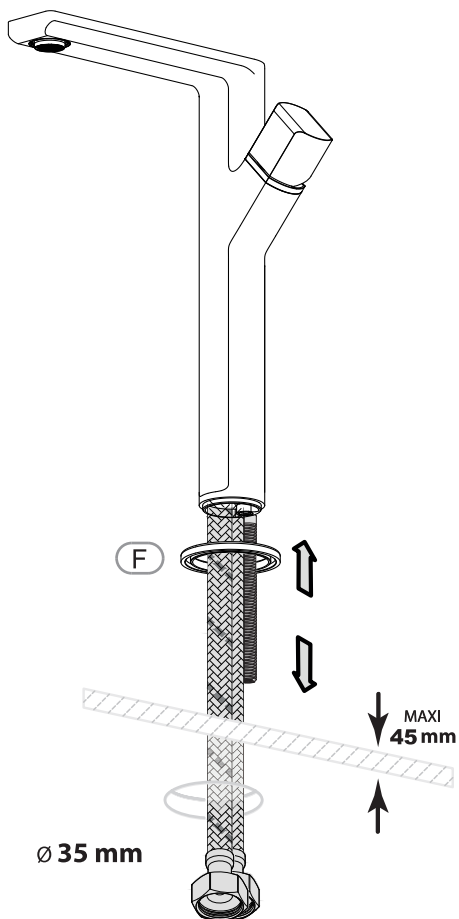



3



B



D

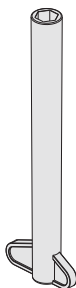

E

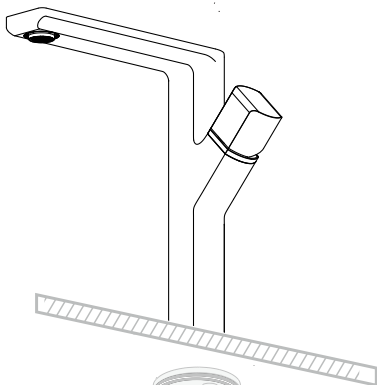

B

D

E

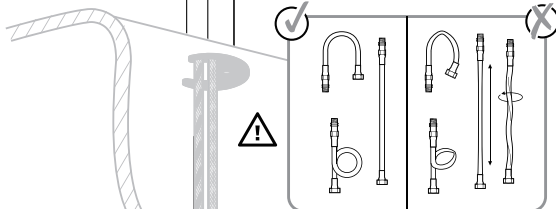
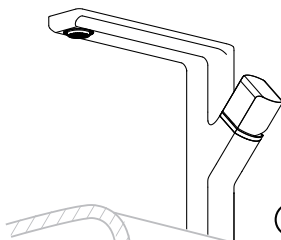
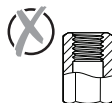

1



2

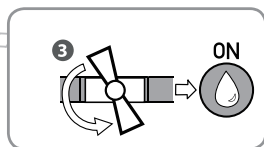

3

ON



FR: Utilisation eau chaude-eau froide/ **ES:** Utilización agua caliente-agua fría/
PT: Utilização água quente-água fria/ **IT:** Uso acqua calda-acqua fredda/ **EL:** Χρήση ζεστού-κρύου νερού/
PL: Użytkowanie zimnej wody-gorącej wody/ **RU:** Використання гарячої води/
KZ: Суық және ыстық суды қолдану/ **UA:** води - холодної води/ **RO:** Utilizare apă caldă-apă rece/
BR: Uso de água quente e fria/ **EN:** Using hot and cold water

1

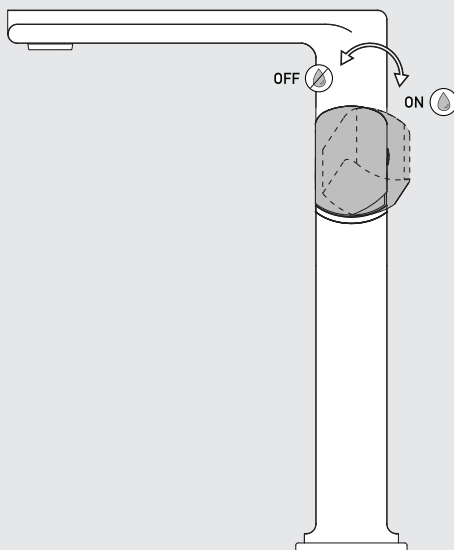

2

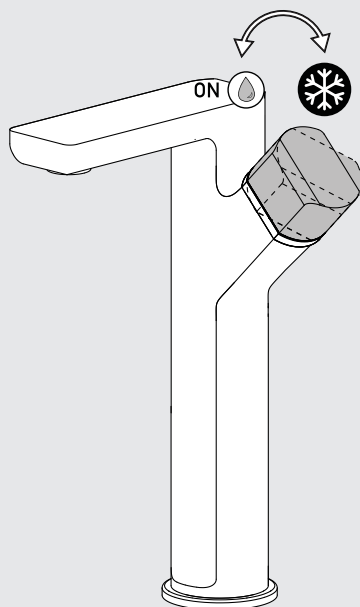
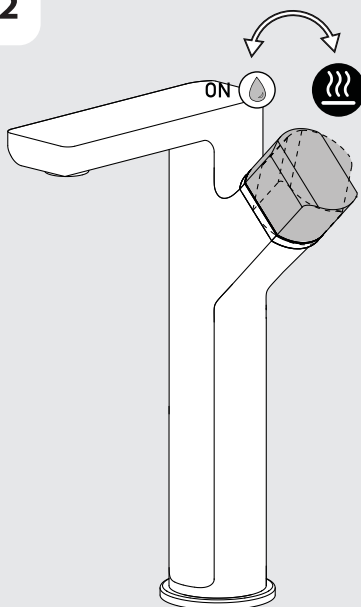

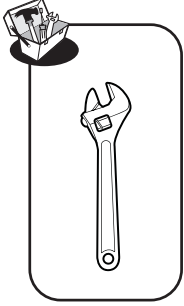

FR: Changement de cartouche/ **ES:** Cambio de cartucho/ **IT:** Cambio cartuccia/
PT: Mudança de cartucho/ **EL:** Αλλαγή φουσιγγίου/ **PL:** Wymiana wkładu / **RU:** Смена картриджа/
KZ: Картриджді ауыстыру/ **UA:** Заміна картриджа/ **RO:** Schimbare cartuş/
BR: Substituição de cartucho/ **EN:** Replacing the cartridge

1

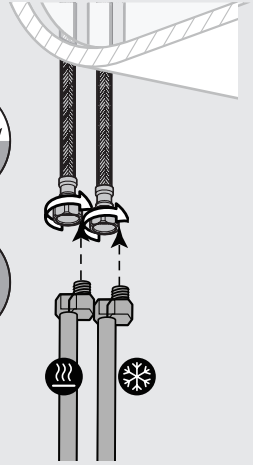
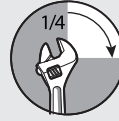
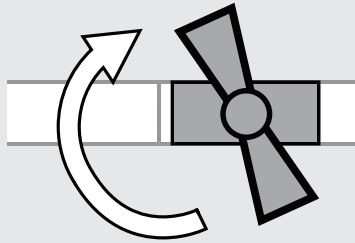

2

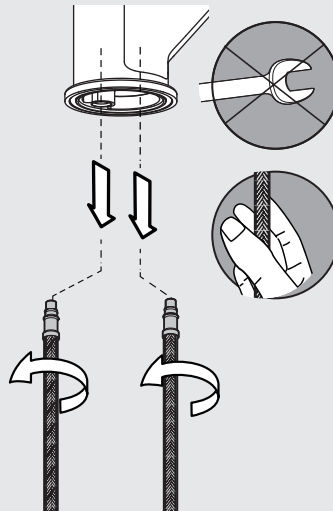

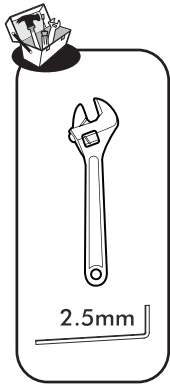

FR: Changement de cartouche/ **ES:** Cambio de cartucho/ **IT:** Cambio cartuccia/
PT: Mudança de cartucho/ **EL:** Αλλαγή φυσιγγίου/ **PL:** Wymiana wkładu / **RU:** Смена картриджа/
KZ: Картриджді ауыстыру/ **UA:** Заміна картриджа/ **RO:** Schimbare cartuş/
BR: Substituição de cartucho/ **EN:** Replacing the cartridge

3

A

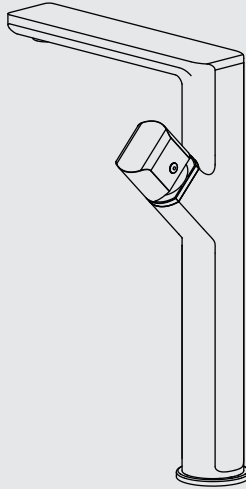

B

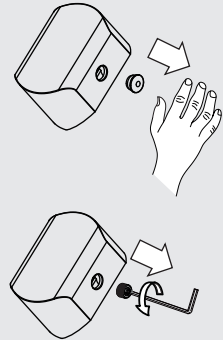

C

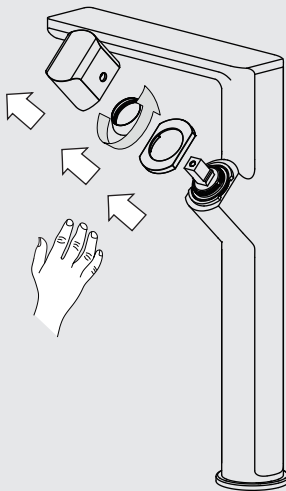

D

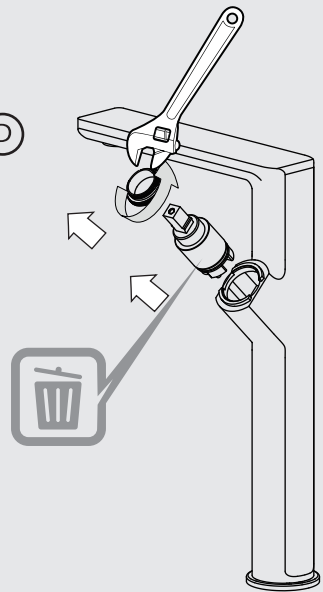

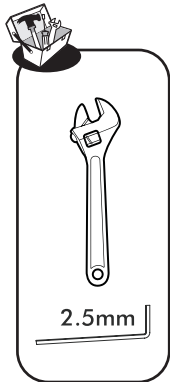

FR: Changement de cartouche/ **ES:** Cambio de cartucho/ **IT:** Cambio cartuccia/
PT: Mudança de cartucho/ **EL:** Αλλαγή φυσιγγίου/ **PL:** Wymiana wkładu / **RU:** Смена картриджа/
KZ: Картриджді ауыстыру/ **UA:** Заміна картриджа/ **RO:** Schimbare cartuş/
BR: Substituição de cartucho/ **EN:** Replacing the cartridge

4

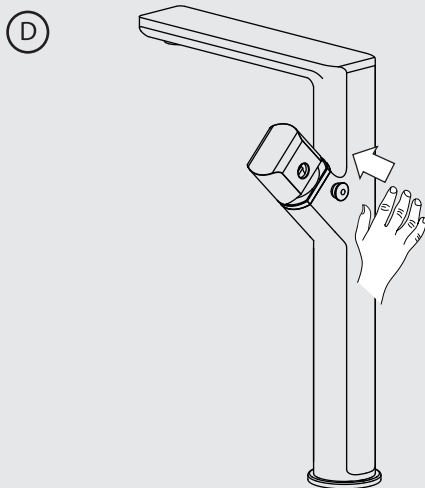
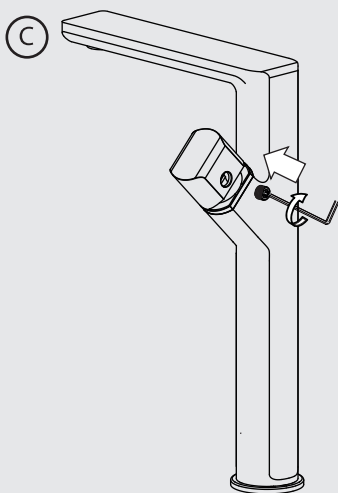
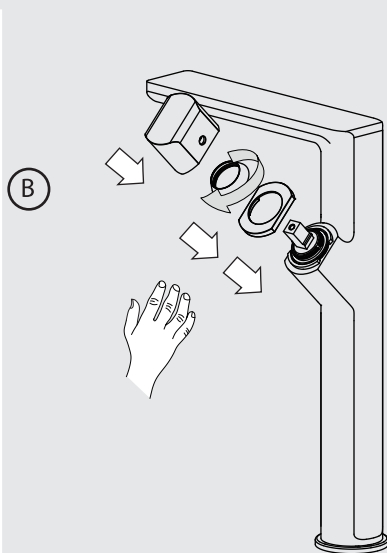
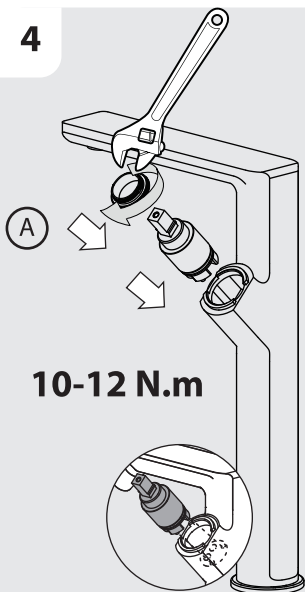



FR: Changement de cartouche/ **ES:** Cambio de cartucho/ **IT:** Cambio cartuccia/
PT: Mudança de cartucho/ **EL:** Αλλαγή φυσίγγιου/ **PL:** Wymiana wkładu / **RU:** Смена картриджа/
KZ: Картриджи ауыстыру/ **UA:** Заміна картриджа/ **RO:** Schimbare cartuş/
BR: Substituição de cartucho/ **EN:** Replacing the cartridge

5

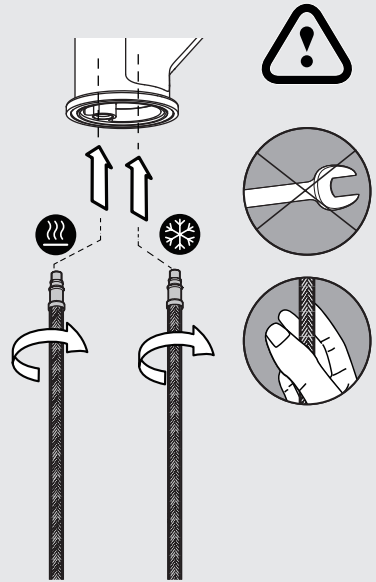
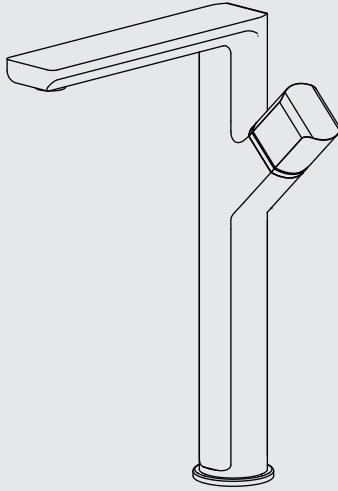

6

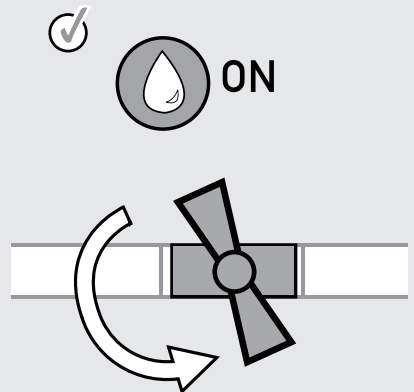
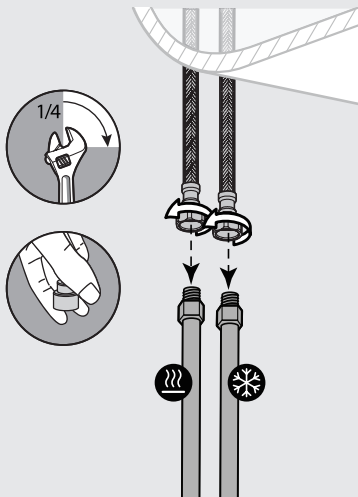

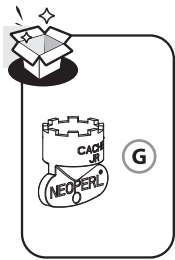

FR: Changement de mousseur/**ES:** Cambio de aireador/**PT:** Mudança de arejador/
IT: Cambio rompigetto/ **EL:** Αλλαγή αεράτορα / **PL:** Wymiana perlatora / **RU:** Смена аэратора/
KZ: Ауақанықтырғышты ауыстыру/ **UA:** Заміна аератора/ **RO:** Schimbare aerator/
BR: Substituição do aerador/ **EN:** Replacing the aerator

1

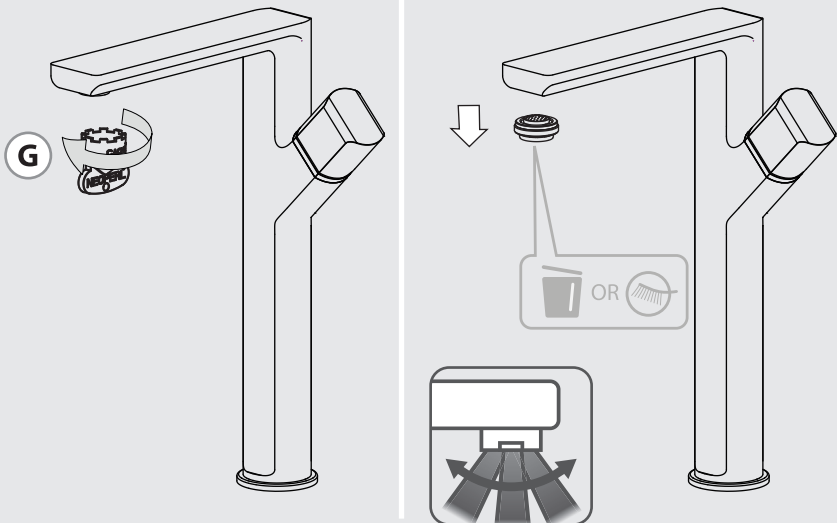

2

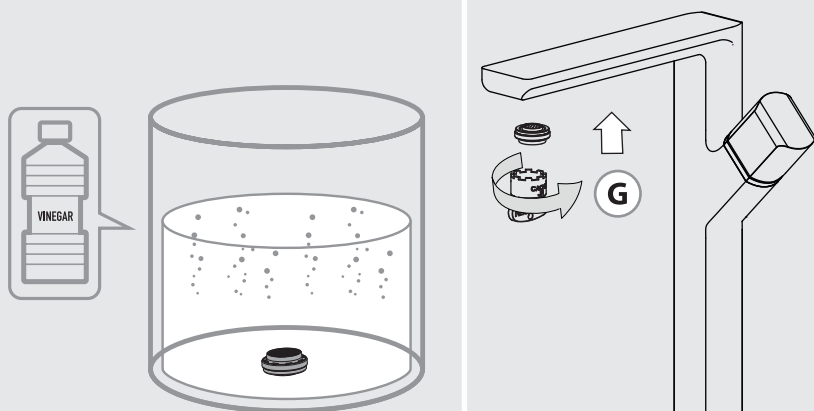

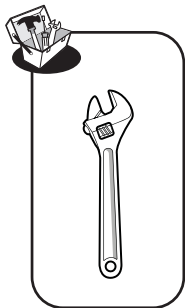

FR: Changement de flexibles/ **ES:** Cambio de flexibles / **PT:** Mudança de flexíveis/
IT: Cambio flessibili/ **EL:** Αλλαγή λάστιχων/ **PL:** Wymiana wężyków instalacyjnych /
RU: Смена гибкого шланга для смесителя/ **UA:** Заміна гнучкого шланга для змішувача/
KZ: Қоспалауышқа арналған иілгіш шлангты ауыстыру/ **RO:** Schimbare furtune flexibile/
BR: Substituição das mangueiras/ **EN:** Replacing the hoses

1

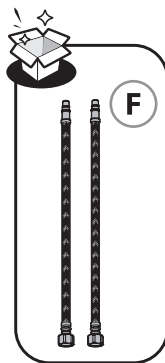
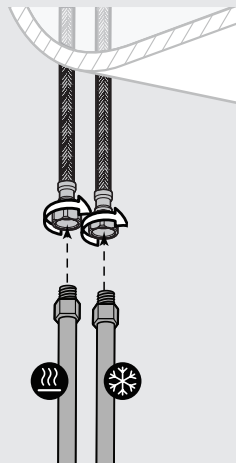
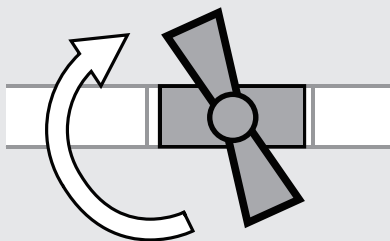

2



ON

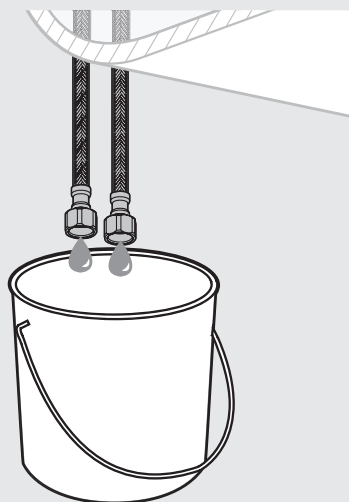
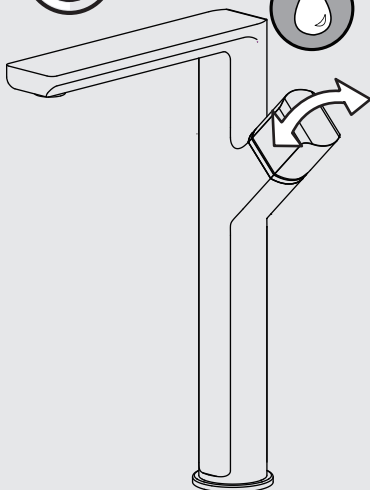

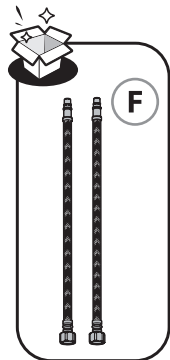

FR: Changement de flexibles/ **ES:** Cambio de flexibles / **PT:** Mudança de flexíveis/
IT: Cambio flessibili/ **EL:** Αλλαγή λάστιχων/ **PL:** Wymiana wężyków instalacyjnych /
RU: Смена гибкого шланга для смесителя/ **UA:** Заміна гнучкого шланга для змішувача/
RO: Schimbare furtune flexibile/ **EN:** Replacing the hoses

3

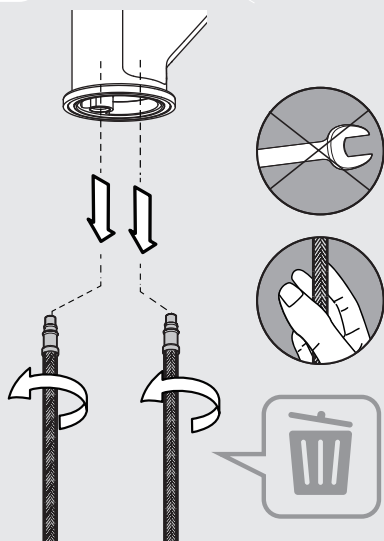

4

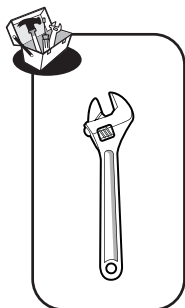
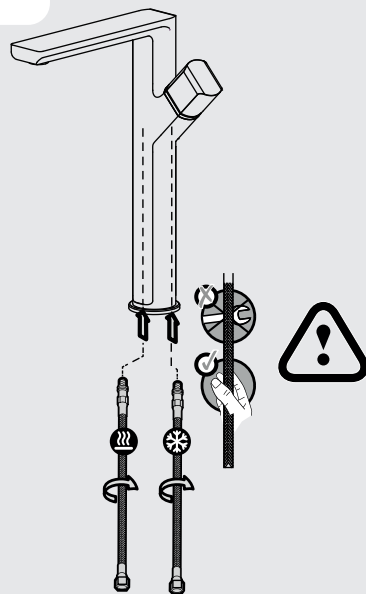

5

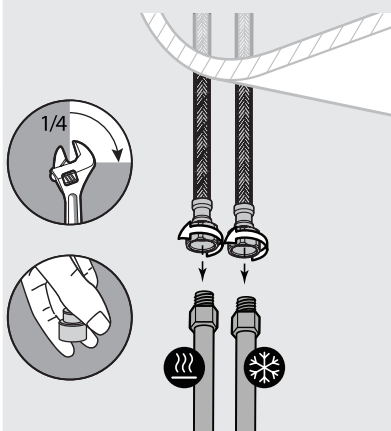

6

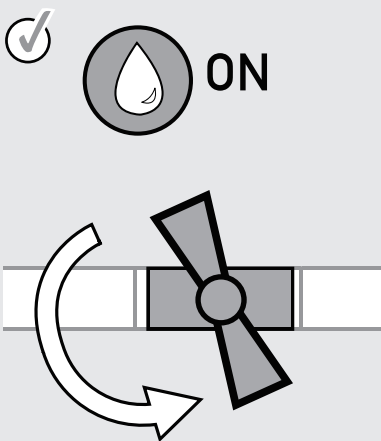

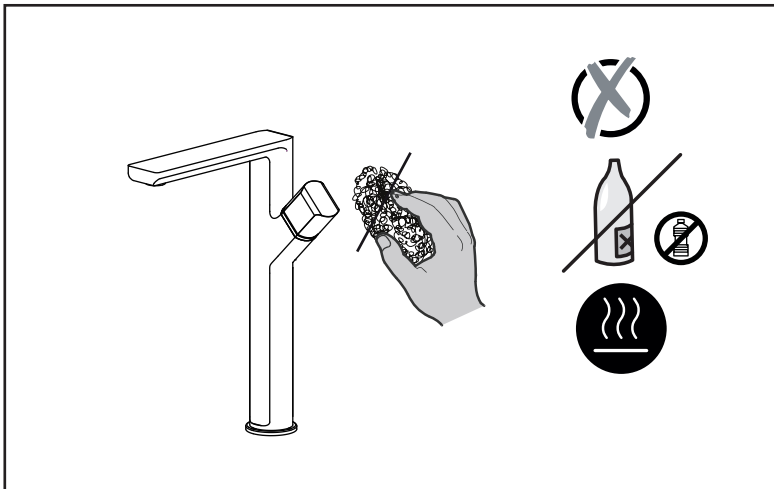
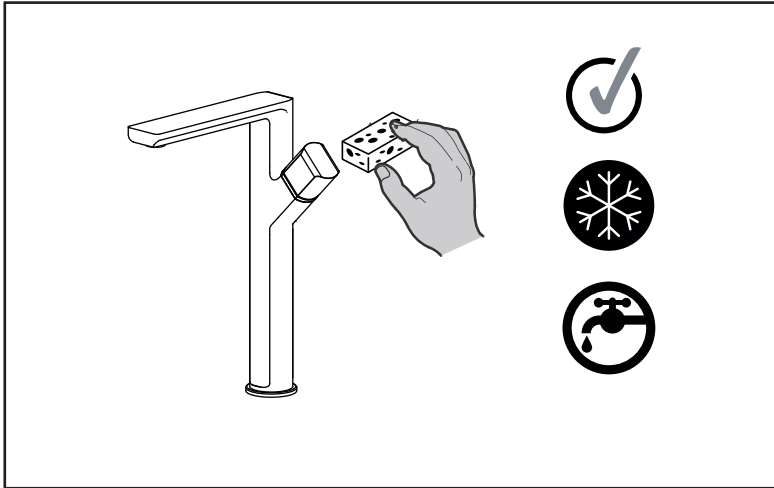



Certificado de conformidad sanitaria.
Atestado de conformidade sanitária.
certificato di conformità sanitaria.
Βεβαίωση υγειονομικής συμμόρφωσης.
Certyfikat zgodności sanitarnej.
Декларация о соответствии санитарным нормам
Санитарлық талаптарға сәйкестік декларациясы
Декларація про відповідність санітарним нормам
Atestat de conformitate sanitară
Certificado de conformidade sanitária.
Declaration of sanitary conformity.
Attestation de conformité sanitaire

* Garantie 5 ans / 5 años de garantía / Garantia de 5 anos / Garanzia 5 Anni / Εγγύηση 5 ετών /
Gwarancja 5-letnia / Гарантия 5 года / Кепілдік 5 жыл / Гарантія 5 років / Garantie 5 ani /
5-year guarantee

Made in china 2018

ADEO Services - 135 Rue Sadi Carnot - CS 00001
59790 RONCHIN - France

UA ТОВ «Леруа Мерлен Україна»,
вул. Полярна 17а, м. Київ 04201, Україна

