



Name: LUA 2 LUCES

Design: Joana Bover / 2002

Typology: Pendant lamp

Environment: Indoor

Technical description:

Pendant lamp with iron structure releasing diffused light through twin lamp shades, available in classic cotton or cream and white translucent hand wrapped polyester blend ribbon. Available in various finishes: black iron, satin nickel, satin nickel with dark leather trim or satin nickel with caramel leather. The upper diffuser is included with the fixture.



Lamps description

⚡ Earthing: compulsory

⚠ Ready for mounting on normally flammable surface

💡 2 x 70 W Classic A ECO E-27

💡 2 x 18 W E-27

Voltage: 230V~50Hz

📦 1 Box 67 x 67 x 27 cm

Vol.: 0,1212 m<sup>3</sup>

Weight: 5 kg

Certifications:  CE

Ref Finishings

4222904 Black iron

4222905 Satin nickel

4222960 Nickel dark leather

4222961 Nickel caramel leather

Lampshade 38 x 20 x 30 cm

P-163 C Cotton

P-167 C Cream translucent ribbon

P-168 C White translucent ribbon

The shade includes upper diffuser

Customizable

Measures

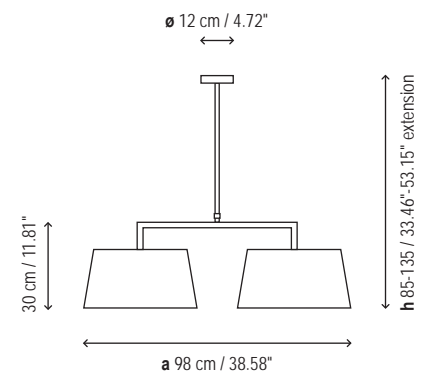

Project information

Project name:

Approved by:

Fixture type:

Date:

Location:

Prepared by:

Comments:

Prepared for:

Photometrics

LUA 1 LUZ

---

