



Name: MEI - 150

Design: Joana Bover / 2004

Typology: Pendant lamp

Environment: Indoor

Technical description

Pendent lamp providing diffused light through a translucent shade of hand wrapped polyester blend ribbon. The canopy is available in brown or black, as well as a satin nickel painted finish. The electrical connection is transparent, and the diffuser is a frosted injection-molded polycarbonate lens. Various tensor wires are available: 1.5, 3, and 5 mt + terminal.



Lamps description

Earthing: compulsory

Ready for mounting on normally flammable surface

6 x 70 W Classic A ECO E-27

6 x 30 W E-27

Voltage: 230V~50Hz

1 Box 157 x 157 x 77 cm

Vol.: 1,8980 m³

Weight: 25 kg

Certifications:

Ref **Finishings**

4619903 Brown iron

4619904 Black iron

4619905 Satin nickel

Lampshade 150 x 70 x 59 cm

P-590C White translucent ribbon

P-591C Cream translucent ribbon

P-592C Red translucent ribbon

P-593C Black translucent ribbon

Diffuser included

Transparent connection

Adjustable tensor wire

Customizable

Measures

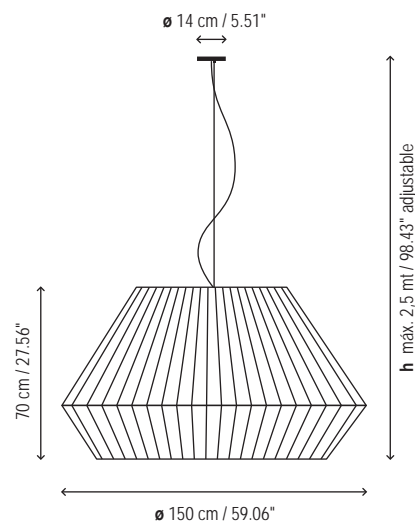

Photometrics

Project information

Project name:

Approved by:

Fixture type:

Date:

Location:

Prepared by:

Comments:

Prepared for:

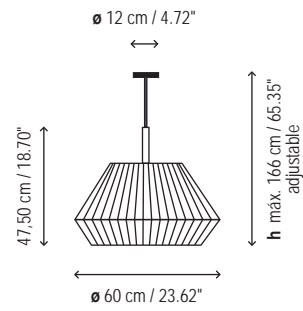
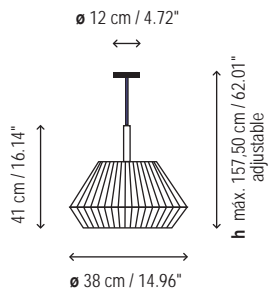

MEI - 90

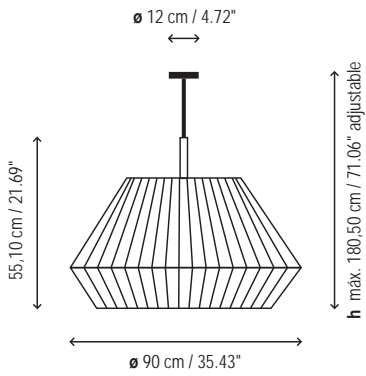

MEI - 125

