

- FR** Notice de Montage, Utilisation, Entretien
- ES** Instrucciones de Montaje, Utilización y Mantenimiento
- PT** Instruções de Montagem, Utilização e Manutenção
- IT** Istruzioni per il Montaggio, l'Uso e la Manutenzione
- EL** Εγχειρίδιο συναρμολόγησης, χρήσης και συντήρησης
- PL** Instrukcja Montażu, Użytkowania i Konserwacji
- RU** Руководство По Сборке и Эксплуатации
- KZ** Пайдаланушы Нұсқаулығы
- UK** Керівництво По Збірці і Експлуатації
- RO** Manual asamblare, utilizare și întreținere
- EN** Assembly - Use - Maintenance Manual

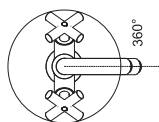

B

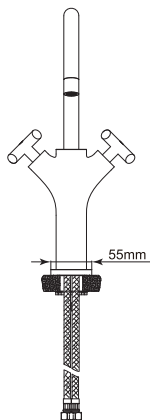
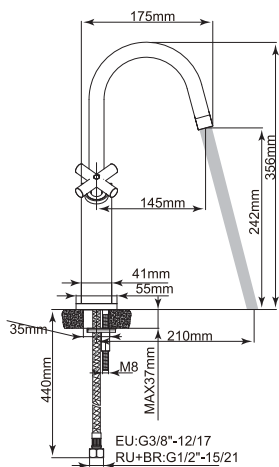
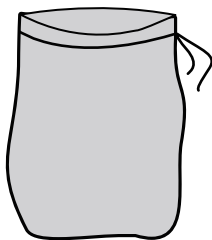
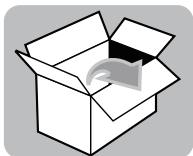

D



E

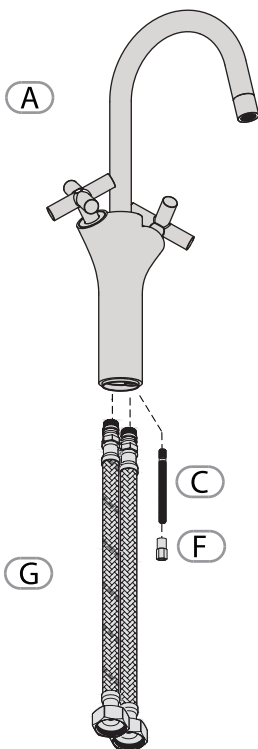

A

G

C

F

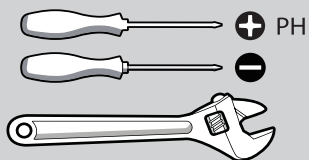
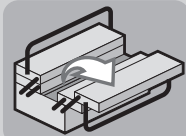

PH

-

2.5mm

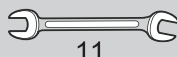

11



30'





Observez / Atención / Aviso / Osservare / Προσέξτε / Przestrzegać / Соблюдайте правила техники безопасности /
□ауіпсіздік техникасы ережелерін са□та□ыздар / Дотримуйтеся правил техніки безпеки / Respe
ctaji / Observe



Nettoyage / Limpieza / Limpeza / Pulizia / Καθαρισμός / Czyszczenie / Чистка / Тазалау / Очищення /
Curățare / Cleaning



Eau claire / Agua limpia / Água limpa / Acqua pulita / Καθαρό νερό / Czysta woda / Чистая вода / Таза су /
Чиста вода / Apă curată / Clean water



Sans solvant / Sin disolvente / Sem solventes / Senza solventi / Χωρίς διαλυτικά / Bez rozpuszczalnika / Без растворителя /
Еріткішсіз / Без розчинника / Fără solvent / Solvent-free



Attendre / Espera / Esperar / Attendere / Αναμονή / Zaczekać / Режим ожидания / К□ту режимі / Режим очікування /
Așteptare / Wait



Maintenance / Mantenimiento / Manutenção / Manutenzione / Σέρβις / Utrzymanie / Техническое обслуживание /
Техникалы□ □ызмет к□рсету / Технічне обслуговування / Mentenanță / Maintenance

Notes / Observaciones / Notas / Note / Σημειώσεις / Notatki / Примечания / Ескерту / Примітки / Note / Notes

1

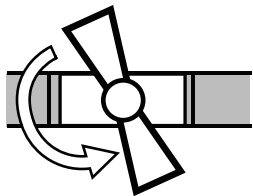

2

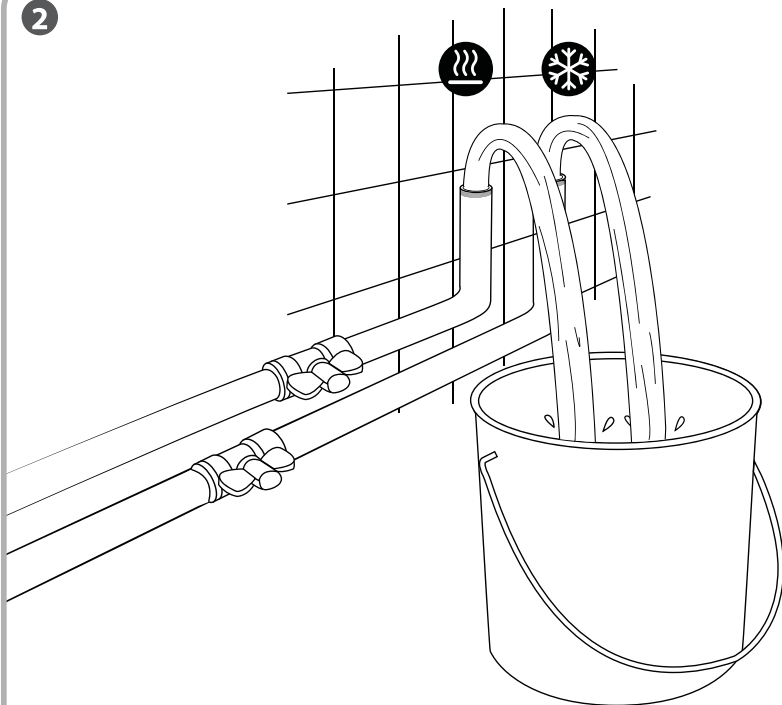

3

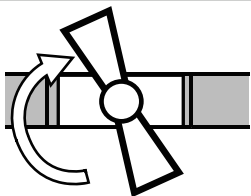

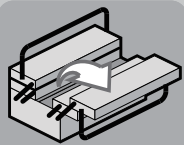
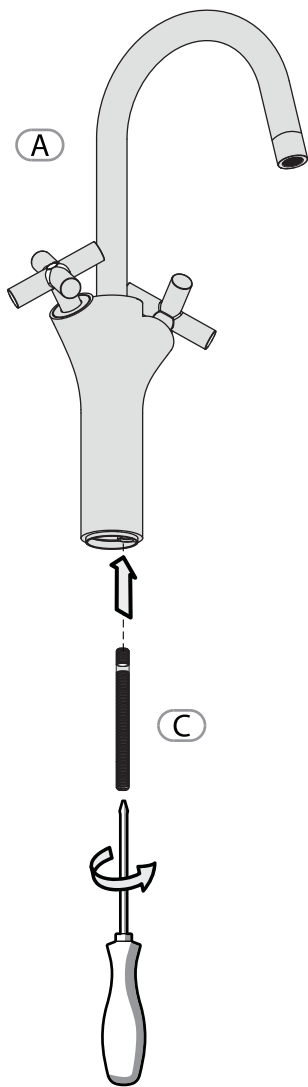

C

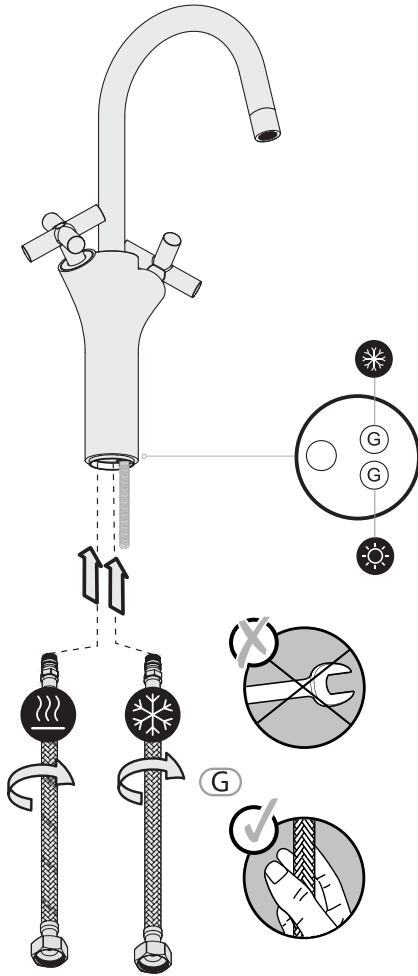

G

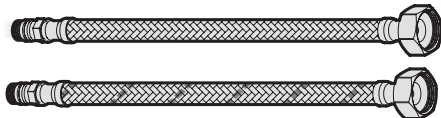

4

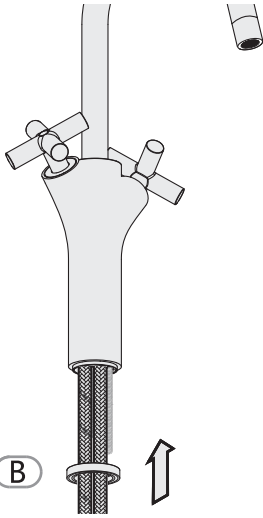

5

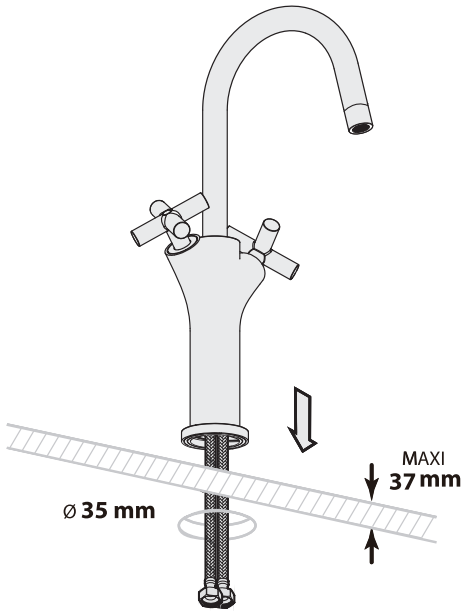

B



6

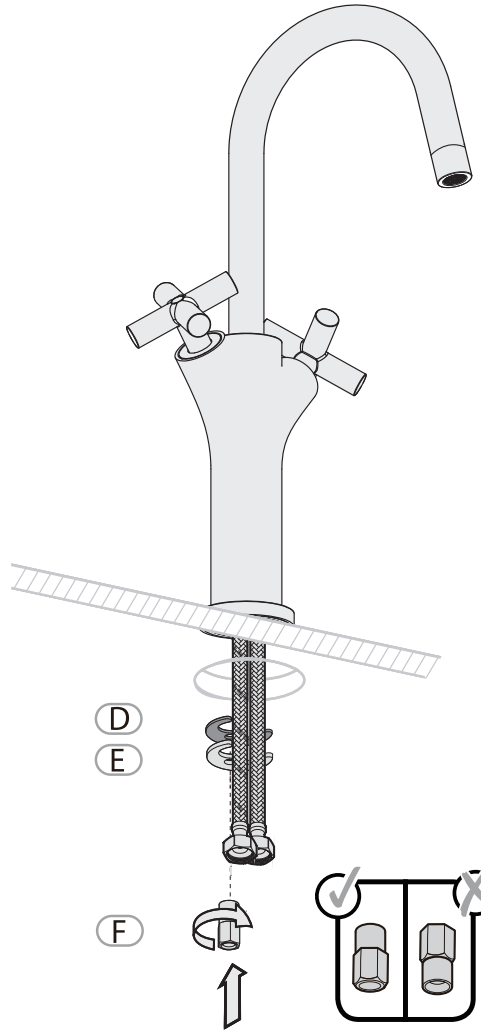

D

E

F

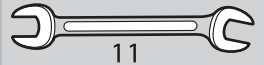
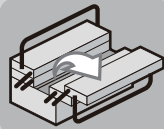

11

D

E

F



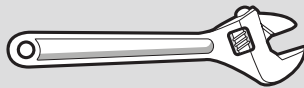
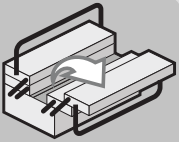
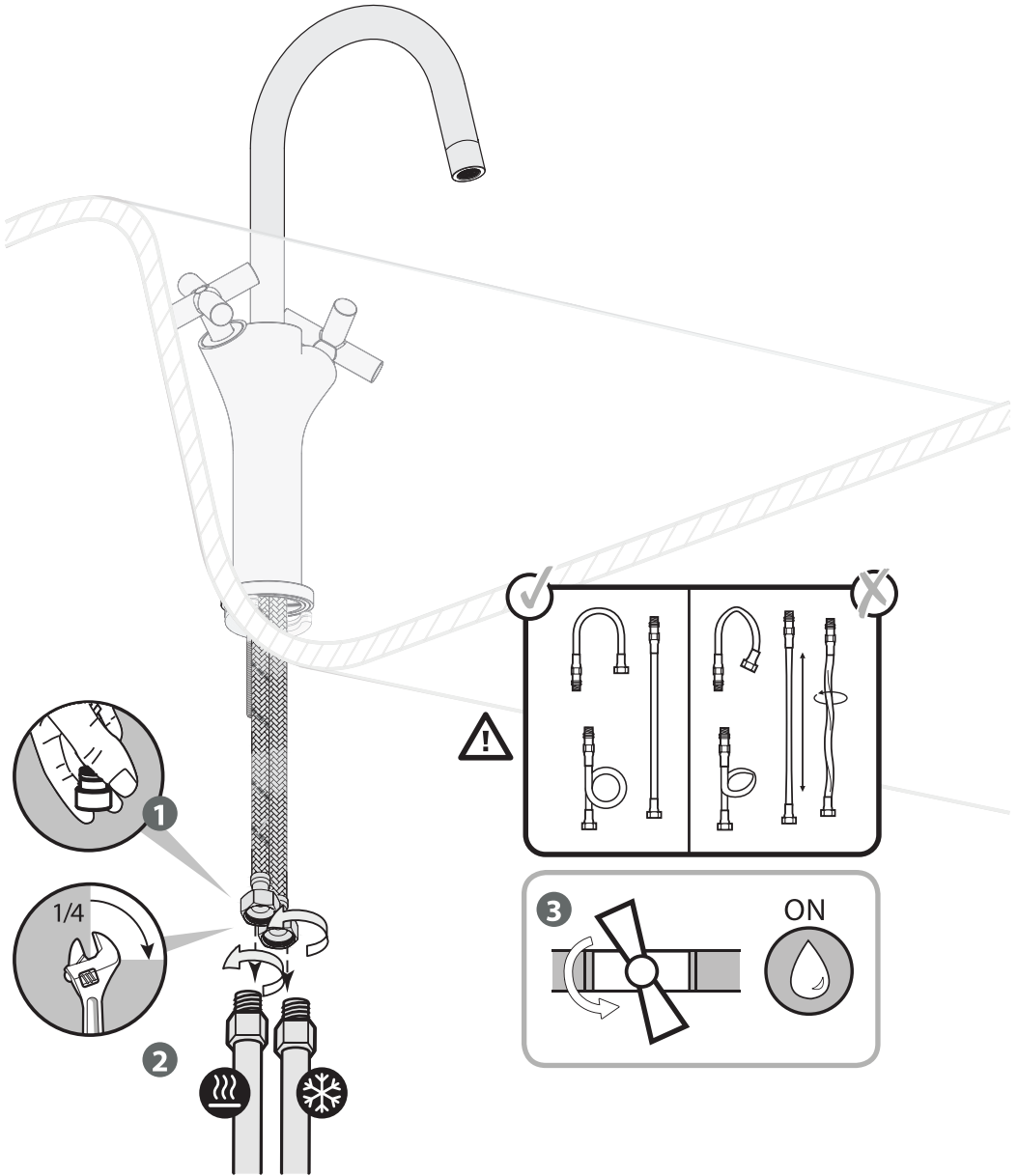

Utilisation eau chaude-eau froide / Utilización agua caliente-agua fría / Utilização água quente-água fria / Uso acqua calda-acqua fredda / Χρήση ζεστού-κρύου νερού / Użytkowanie zimnej wody-gorącej wody / Использование горячей воды - холодной воды / Використання гарячої / Суцйк және ыстық суды қолдану / води - холодной води / Utilizare apă caldă-apă rece / Using hot and cold water

A

1

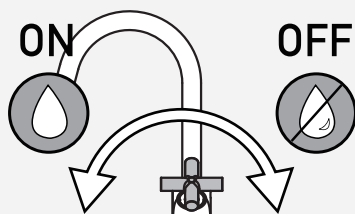
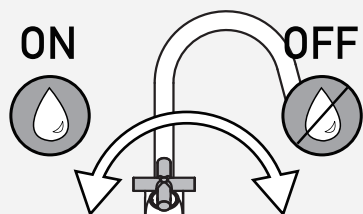

B

Changement de cartouche / Cambio de cartucho / Mudança de cartucho / Cambio cartuccia
Αλλαγή φυσιγγίου / Wymiana wkładu / Смена картриджа / Картриджді ауыстыру/
Заміна картриджа / Schimbare cartuş / Replacing the cartridge

1

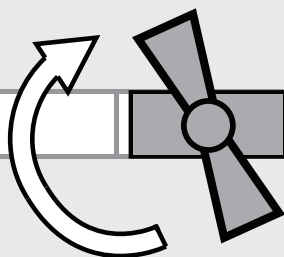

2

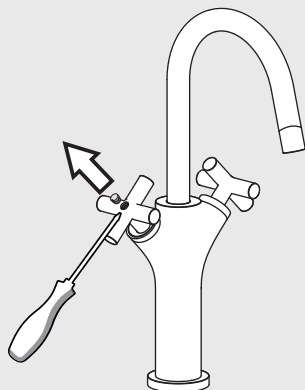

3

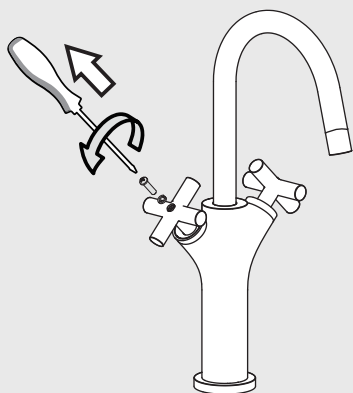

+ PH

4

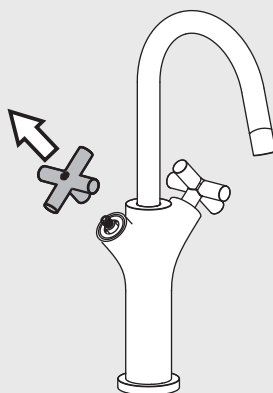

Changement de cartouche / Cambio de cartucho / Mudança de cartucho / Cambio cartuccia
Αλλαγή φυσιγγίου / Wymiana wkładu / Смена картриджа / Картриджді ауыстыру/
Заміна картриджа / Schimbare cartuş / Replacing the cartridge

B

5

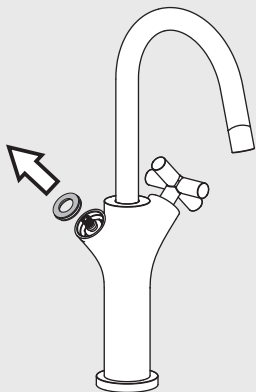

6

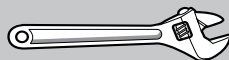
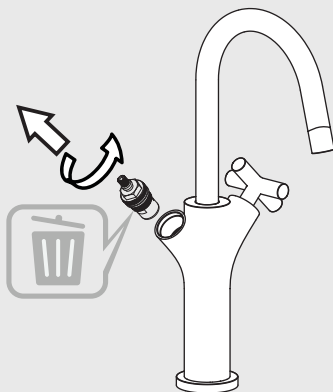

7

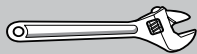
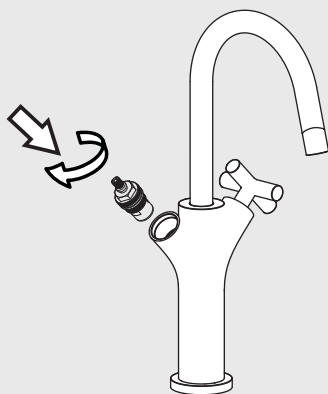

8

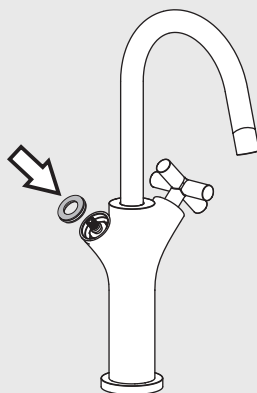

B

Changement de cartouche / Cambio de cartucho / Mudança de cartucho / Cambio cartuccia
Αλλαγή φυσίγγιου / Wymiana wkładu / Смена картриджа / Картриджді ауыстыру/
Заміна картриджа / Schimbare cartuş / Replacing the cartridge

9

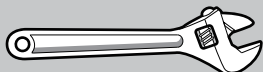
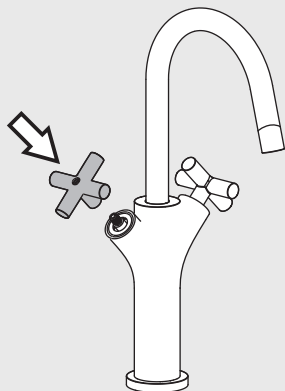

10

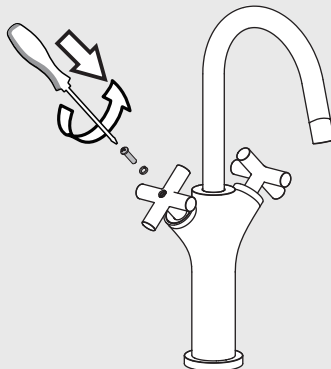

11

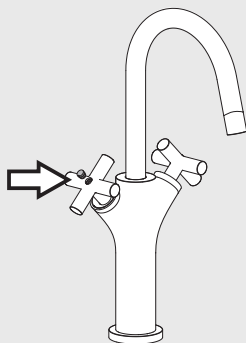

12

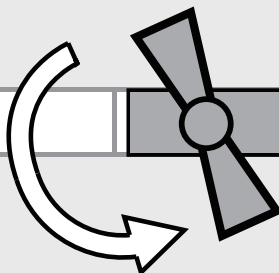

Changement de mousseur / Cambio de aireador Mudança de arejador / Cambio rompigetto / Αλλαγή αεράτορα / Wymiana perlatora / Смена аэратора / Ауақаны-қытырғышты ауыстыру / Заміна аератора / Schimbare aerator / Replacing the aerator

C

1

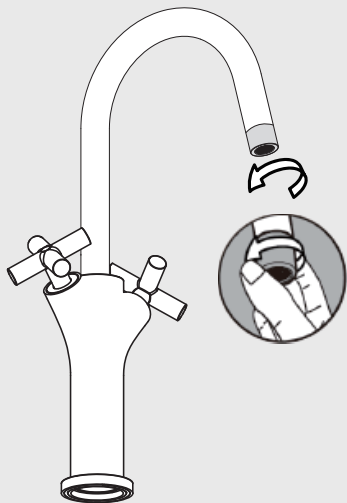

2

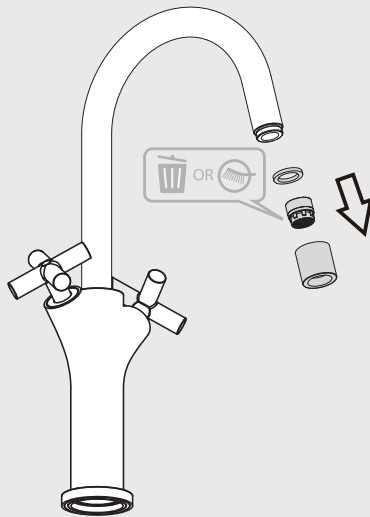

3

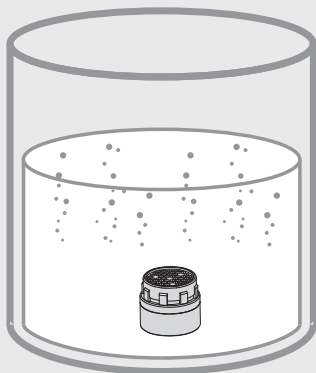

4

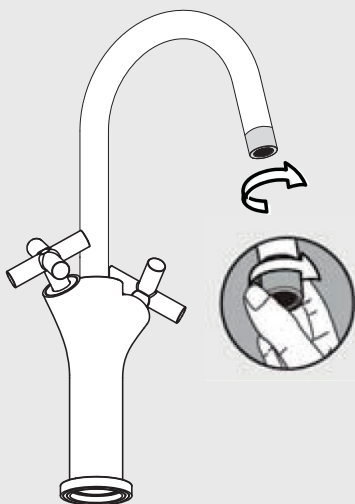

D

Changelement de flexibles / Cambio de flexibles / Mudança de flexíveis / Cambio flessibili / Αλλαγή λάστιχων / Wymiana wężyków instalacyjnych / Смена гибкого шланга для смесителя / Заміна гнучкого шланга для змішувача / Қоспалауышқа арналған иілгіш шлангты ауыстыру / Schimbare furtune flexibile / Replacing the hoses

1

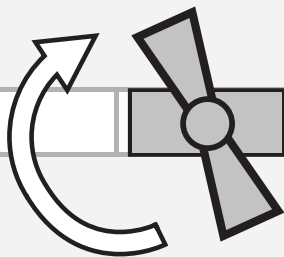
**OFF**

2

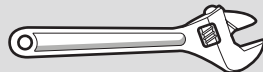
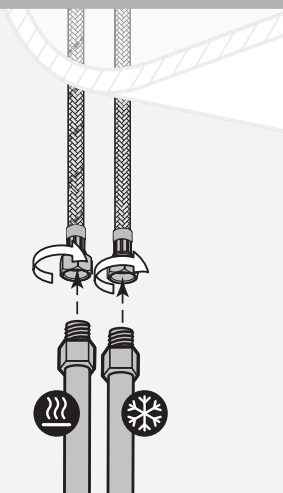

3

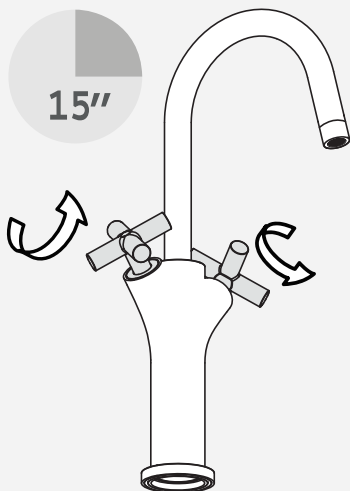

15"

4

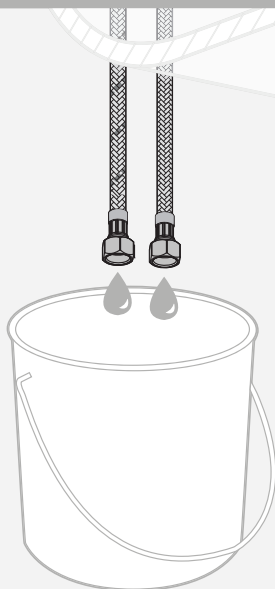

Changement de flexibles / Cambio de flexibles / Mudança de flexíveis / Cambio flessibili / Αλλαγή λάστιχων / Wymiana wężyków instalacyjnych / Смена гибкого шланга для смесителя / Заміна гнучкого шланга для змішувача / Қоспалауышқа арналған иілгіш шлангты ауыстыру / Schimbare furtune flexibile / Replacing the hoses

D

5

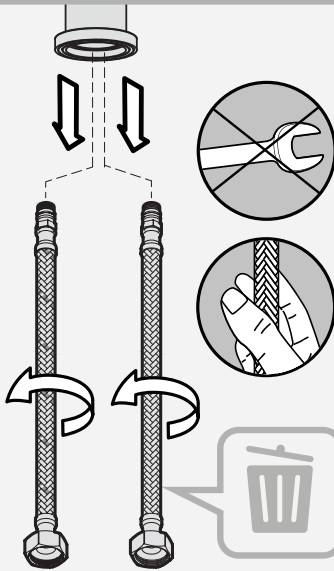

6

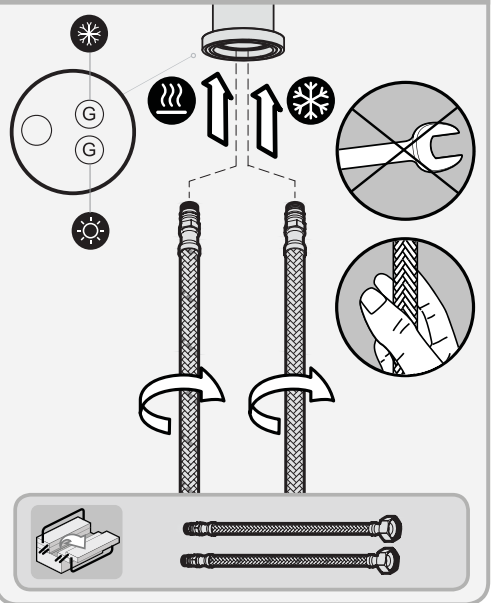

7

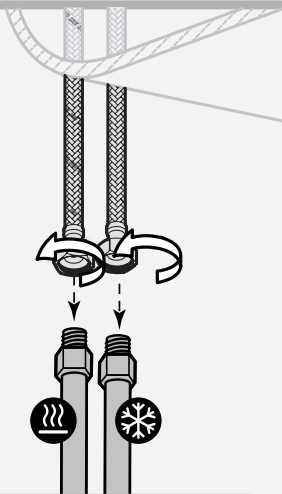

8



ON

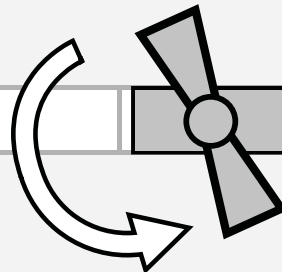

ADEO Services
135 Rue Sadi Carnot
CS 00001
59790 RONCHIN - France

ТОВ «Леруа Мерлен Україна»,
вул. Полярна 17а, м. Київ
04201, Україна

ООО ЛЕРУА МЕРЛЕН ВОСТОК,
141031, Московская область,
Мытищинский район, г. Мытищи,
Осташковское шоссе, д.1, РОССИЯ

* Garantie 5 ans / Garantía 5 años / Garantia 5 anos / Garanzia 5 anni
Εγγύηση 5 ετών / Gwarancja 5 lat / 5 летняя / 5 жылдық кепілдік /
5-річна гарантія / 5 ani garanție / Guarantee 5 years

Made In P. R.C. 2016