

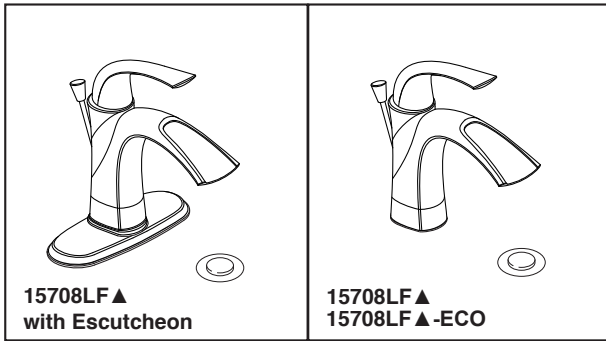

see what Delta can do™

BATHROOM FAUCET

■ Single Handle Deck Mount



Submitted Model No.: _____

Specific Features: _____

STANDARD SPECIFICATIONS:

- Max flow rate 1.5 gpm @ 60 psi, 5.7 L/min @ 414 kPa
- Max flow rate (ECO models only) 1.2 gpm @ 60 psi, 4.5 L/min @ 414 kPa
- One or three hole mount (escutcheon optional, included)
- Control mechanism is replaceable cartridge with ceramic plates

WARRANTY

- Parts and Finish - Lifetime limited warranty; or for commercial purchasers, 10 years for multi-family residential (apartments and condominiums) and 5 years for all other commercial uses, in each case from the date of purchase.
- Electronic Parts and Batteries (if applicable) - 5 years from the date of purchase; or for commercial purchasers, 1 year from the date of purchase. No warranty is provided on batteries.



COMPLIES WITH:

- ASME A112.18.1 / CSA B125.1
- ASME A112.18.2 / CSA B125.2

♿ Indicates compliance to ICC/ANSI A117.1 - Valve control only

- EPA WaterSense®
- Verified compliant with 0.25% weighted average Pb content regulations.

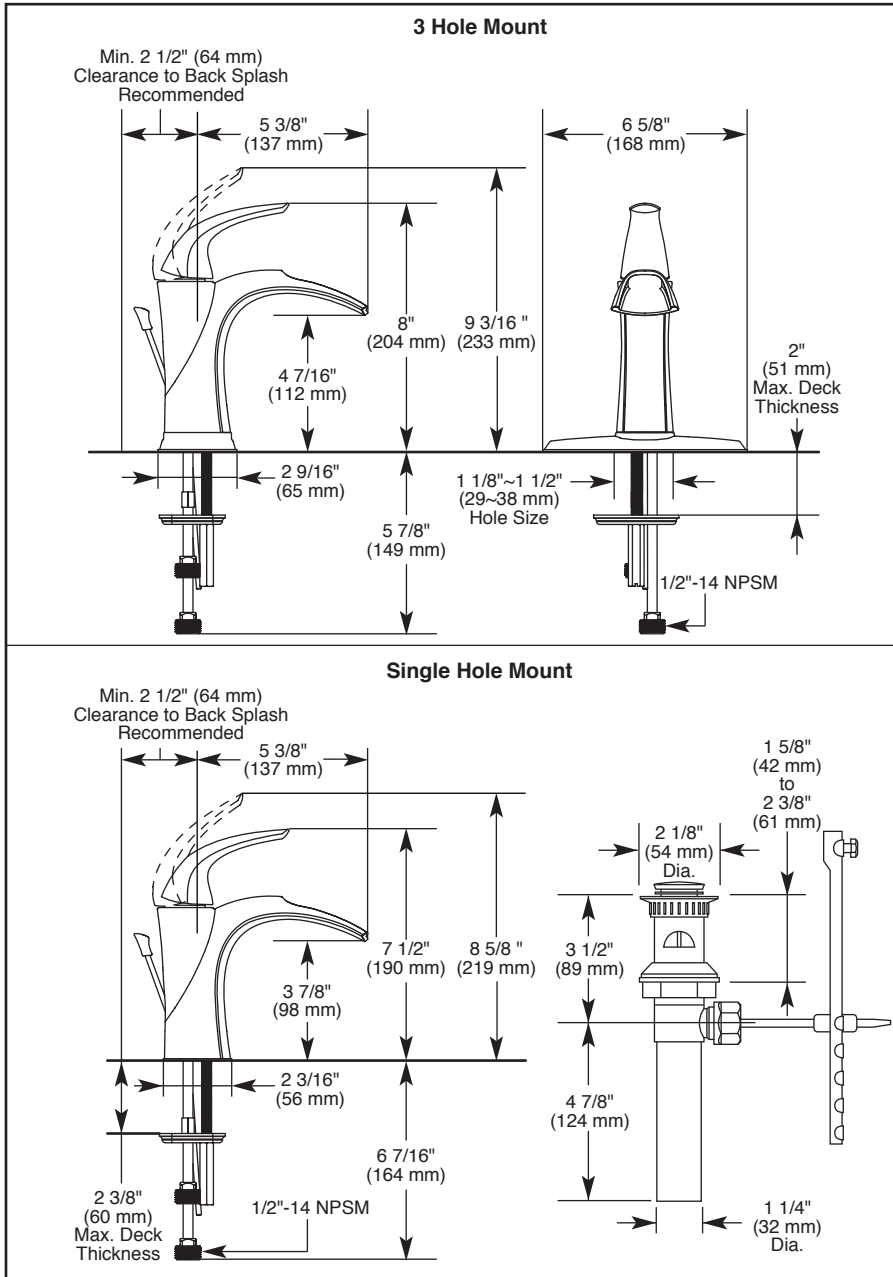

▲ Designate Proper Finish Suffix

Delta reserves the right (1) to make changes in specifications and materials, and (2) to change or discontinue models, both without notice or obligation. Dimensions are for reference only. See current full-line price book or www.deltafaucet.com for finish options and product availability.

DSP-L-15708LF Rev. D

Delta Faucet Company

55 E. 111th Street, Indianapolis, IN 46280
350 South Edgeware Road, St. Thomas, ON N5P 4L1
© 2020 Delta Faucet Company