

E75204



Collection: NO COLLECTION

Finish*:



CP - Chrome

Main features:



Features

- DIMENSIONS: 175 x 175 cm
- MATERIAL: Metal
- WEIGHT: 0.3 kg
- Metallic, double-interlock, anti-twist hose 1.75 m - 1 swivel conical nut - 1 écrou droit

Technical drawing

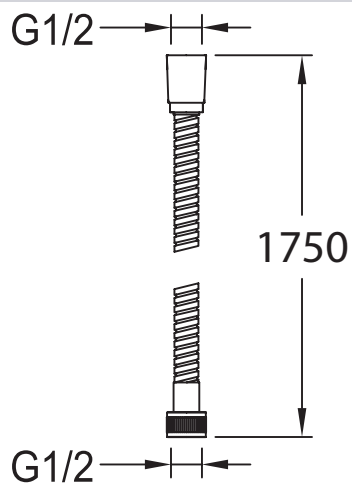

Product Specification: Metallic hose. E75204. Collection: NO COLLECTION. DIMENSIONS: 175 x 175 cm. WEIGHT: 0.3 kg. MATERIAL: Metal. Metallic, double-interlock, anti-twist hose 1.75 m - 1 swivel conical nut - 1 écrou droit.