

## VINCI WALL HUNG MODULE 2 DRAWERS

### Materials

- **Aluminum structure matt black:**  
Aluminum structure, square section tube of 20x20mm. Matt black lacquered finish.
  - **Fronts and Sides Panels (Thickness = 16 mm):**  
- Africa oak: Laminated particle board laminated with wood termination and pvc / abs edges with PUR glue.
  - **Internal Structure panels (Thickness = 16mm):** Laminated particle board with neutral finish and PVC edges.
- \* All panels used in the manufacture of this unit are classed as E-1 grade with low level of formaldehyde content.
- \*Trim varies according to design: PVC, ABS. (edged with PUR glue)
- **Drawers:** Wooden drawers with hidden extraction guides plus and interior Carbon - Tx.
  - **Handles:** aluminum in matt black finish.

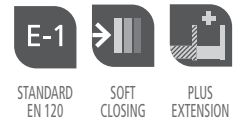

### Metal Fittings

- **Wall brackets:** high resistance wall brackets with two independent regulations.

### Packaging Dimensions and weight (mm).

	400
Length	445
Profundity	500
Height	620
Net Weight	17,5
Gross Weight	19,22



### Interior drawer finishes



### Vanity finishes

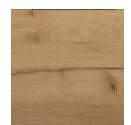

Africa Oak

### Vanity dimensions

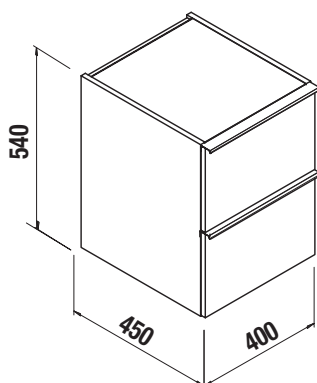

WASHBASIN MODULE ON THE RIGHT  
850 / 1000/ 1200

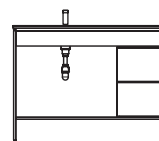

WASHBASIN MODULE ON THE LEFT  
850 / 1000/ 1200

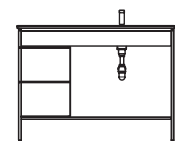

CENTERED SINK WASHBASIN (1 OR 2  
MODULES) 1000 / 1200

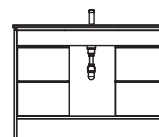

DOUBLE SINK WASHBASIN  
1200

